

THE INSTITUTE FOR ANALYTICAL PHILATELY, INC.

# Proceedings of the Second International Symposium on Analytical Methods in Philately

Edited by

*John H. Barwis, Thomas Lera*



## ABSTRACT

Barwis, John H. and Thomas Lera. Proceedings of the Second International Symposium on Analytical Methods in Philately. X + 144 pages, 159 figures, 18 tables, 2016. This publication contains papers presented at the Second International Symposium on Analytical Methods in Philately at CHICAGOPEX 2015, hosted by the Institute of Analytical Philately, in Itasca, Illinois, November 2015. The papers range from computerized image analysis to statistical modeling, compositional and physical characteristics of stamps and paper, and the use of scientific equipment to determine whether a stamp is genuine or counterfeit. Some of the papers were funded, in part, by The Institute for Analytical Philately, Inc. and the use of non-destructive scientific equipment was provided by the Smithsonian National Postal Museum in Washington D.C.

---

Published by The Institute for Analytical Philately, Inc.  
PMB 31  
1668 Merriman Road  
Akron, OH 44313

Design and Layout by Amanda L. Morgenstern  
Printed by Wilcox Printing & Publishing, Inc., 102 S. Main St., PO Box 167, Madrid, IA 50156

Compilation copyright © 2016 The Institute for Analytical Philately, Inc.

The rights to the text and images in this publication, including cover and interior design, are owned by The Institute for Analytical Philately, Inc. contributing authors, or third parties. Use of materials is permitted only for personal, educational, or noncommercial purposes. Users must cite author, source of content and are responsible for securing permission from the rights holder for any other use.

ISBN: 978-0-9978529-0-5 (print); 978-0-9978529-9-8 (EPub/pdf)

# Contents

---

WELCOME LETTERS	<b>vii</b>
<i>John H. Barwis</i> <i>Allen Kane</i>	
PREFACE	<b>ix</b>
<i>John H. Barwis and Thomas Lera</i>	
Keynote Address: Retrospective of Technical Research in Philately	<b>1</b>
<i>Robert Odenweller</i>	
Paper and Color Varieties of the People's Republic of China "Workers and Soldiers" Definitive Set of 1955-1961	<b>9</b>
<i>Archie McKee</i>	
The Admiral Issue of Canada: A Colorimetric and XRF Study of the Carmine 2¢ Issue	<b>21</b>
<i>Richard Judge</i>	
Towards a Stamp-Oriented Color Guide: Objectifying Classification by Color	<b>31</b>
<i>John Cibulskis</i>	
Resolving the Scanner Dependency in Color Matching	<b>41</b>
<i>John Cibulskis</i>	
Ink Composition of the U.S. 3c Stamps 1870-1883	<b>49</b>
<i>John H. Barwis and Harry G. Brittain</i>	
Digital Image Differencing of High Resolution Stamp Images	<b>57</b>
<i>Robert Mustacich</i>	
Measurements of Stamp Separation Features by Digital Image Analysis	<b>73</b>
<i>Robert Mustacich</i>	
Shade Verifications Using Tonal Histogram Analyses	<b>87</b>
<i>Tim Lyerla</i>	
Rosette Eagles of Mexico - Microscopic Analysis of Paper Content of Mystery Mexican Stamps Confirms Origin and Date	<b>95</b>
<i>Farley Katz</i>	





Modeling Postal History with Postal Numbers <i>Diane DeBlois &amp; Robert Harris</i>	<b>103</b>
Canada 1868 Two Cent Large Queen on Laid Paper Variety: The Analytical Process Followed for Expertization <i>Ted Nixon</i>	<b>115</b>
A General Characterization of the Purpose, Role and Responsibilities of Experts and Expertizing Groups When Addressing “Damaged Material” <i>Jonas Hällström</i>	<b>125</b>
ABSTRACTS	
Analysis of Pigment Composition of the U.S. 5c 1847 Issue <i>Gordon Eubanks</i>	<b>131</b>
The Use of X-ray Fluorescence in Detecting Philatelic Forgeries <i>Thomas Lera</i>	<b>133</b>
A New Technique for Analyzing the Optical Spectra of Stamp Inks: U.S. 1861 Stamps <i>Ted Liston</i>	<b>135</b>
Application of Advanced Tools to Persian Philately <i>Joe Youssefi</i>	<b>137</b>
SUPPORT THE INSTITUTE FOR ANALYTICAL PHILATELY	<b>139</b>
APPLICATION FOR AN IAP RESEARCH GRANT	<b>141</b>
2017 CALL FOR PAPERS FOR THE THIRD INTERNATIONAL SYMPOSIUM IN LONDON	<b>143</b>



# Welcome Letters

---

July 15, 2016

The contributions published here reflect a small but rapidly growing area of our hobby: the use of science and technology to better understand how philatelic materials were made, and better define what makes them genuine. Yet for every such study being done, ideas from fellow collectors suggest at least five intriguing research ideas not being pursued. I believe there are three reasons for this.

The first is, “I don’t know what questions to ask!” That may be true, but you do know what sparked your curiosity! A short, informal conversation with any member of the IAP board can help clarify the kinds of analyses that could shed light on the mystery at hand. Some of the papers in this volume document authors’ first forays into technical work. No need to be embarrassed about asking questions – we are all learners.

The second is, “I don’t know how to run any of the lab equipment, and won’t understand the data produced!” Again, there is no cause for worry. At the National Postal Museum’s lab, you, the researcher, will be taught how to use the equipment, interpret the data, and draw conclusions from the results. The process is far easier than you might imagine.

The third is, “I cannot afford to do this.” Cost will not be burdensome. Not only will your analyses at the National Postal Museum cost you nothing, but your travel and lodging expenses could be paid by an IAP research grant.

The IAP exists solely to help you, so please jump in and enjoy the fun!

*John H. Barwis*  
*Institute of Analytical Philately, President*

July 15, 2016

It is my great pleasure to present the *Proceedings of the Second International Symposium on Analytical Methods in Philately*, hosted by the Institute of Analytical Philately and Smithsonian National Postal Museum (NPM) on 17–18 November 2015, in Itasca, Illinois immediately prior to the Chicago Philatelic Society Stamp Exhibition.

This second international symposium offered an opportunity for interested philatelists and scientists to get together, share their methodologies, highlight new technologies, provide long-term, wide-ranging benefits to all aspects of philately, and help set the course for future forensic analyses in the philatelic arena. Our close working relationship over the past six years with the Institute for Analytical Philately, Inc. was a huge plus for philatelists because the NPM allowed use state-of-the-art equipment for their advanced research efforts.

The success of the symposium was due in large part to John Barwis, president, James Allen, director, and Thomas Lera, NPM Winton M. Blount Research Chair as well as the speakers and the more than 80 attendees. Special thanks go to James Allen who coordinated the two-day event. Without his efforts, the symposium would not have been as great a success.

If you enjoy these papers as much as I hope you will, please continue to support the Institute for Analytical Philately, the National Postal Museum, and future symposia.

*Allen Kane*  
*Director, National Postal Museum*



# Preface

---

The Institute for Analytical Philately, Inc. (IAP) was formed in 2010 as a philanthropic, nonprofit corporation dedicated to deepening the understanding of philatelic materials through the use of scientific technology and publication of experimental results. The support IAP provides can be tailored to the needs of any philatelist, from those with no scientific background to those with advanced degrees in science or engineering.

IAP grants typically range from \$2,000 to \$4,000 and are intended to help fund travel, lodging, and laboratory use. Additional funding may be available through cost sharing with alliance members, who can also provide advice on previous work done in a particular area or help to conceive and plan a research effort. Detailed information on grants can be found on page 141.

Researchers may conduct their work anywhere they choose, but are encouraged to take advantage of the facilities and expertise available at IAP's centers of excellence, like the state-of-the-art equipment and experienced advisors found available at the Center for Ink and Printability at Western Michigan University and at the Smithsonian National Postal Museum.

This book contains papers presented at the Second International Symposium on Analytical Methods in Philately, in Itasca, Illinois, November 17–18, 2015.

Readers will find insights to research methods used across the entire spectrum of philatelic interests, from the composition and physical characteristics of paper, to the chemistry and mineralogy of printing ink, to determining the genuineness of stamps and overprints, to the uses of adhesives on cover. Some of these projects were funded in part by IAP. Some of the presenters have already had their research published and for those presentations abstracts and citations are included.

The next international symposium is scheduled to be held in London on October 13–15, 2017. In the meantime, we encourage you to get involved in investigating philatelic mysteries. For more information about IAP visit [www.analyticalphilately.org](http://www.analyticalphilately.org).

All Scott Numbers listed in this book are from the six volume Scott 2015 standard postage stamp catalogue. Sidney, OH: Scott Publishing Company. (Vol. 1. United States and affiliated territories, United Nations, Countries of the World A-B; Vol. 2. Countries of the World C-F; Vol. 3. Countries of the World G-I; Vol. 4. Countries of the World J-M, Vol. 5. Countries of the World N-Sam; and, Vol. 6. Countries of the World San-Z).

*John H. Barwis, FRPSL, FRPSV*

*Thomas Lera, FRPSL*



# Keynote Address: Retrospective of Technical Research in Philately

*Robert Odenweller*

---

We have gathered here for two days to discuss analytical inspection of philatelic material. A number of presentations will concentrate on techniques and procedures that have become available in recent years. It's only natural to think advanced techniques are a recent discovery. Not so.

## **1910-1960**

What was high tech in 1910? A couple of magnifying glasses, 3x and 10x preferably, a perf gauge, and watermark fluid. Later on, a UV lamp may have been added to the list (Fig. 1). But more than 100 years ago, a major innovator introduced a microscope he had expressly designed for examining stamps. W.H.S. Cheavin (1885-1968) was a philatelist and an expert in microscopes. He determined that the usual microscope's magnification of more than 18x was too powerful to be useful for philately, so he designed the Watson Philatelic Microscope, which had a basic range of 6x to 18x (Fig. 2).



---

FIGURE 1. Early Scientific Equipment.

---

W. WATSON & SONS, 313, HIGH HOLBORN, LONDON, W.C. 5

## Watson's Philatelic Microscope.

Designed by Mr. HAROLD S. CHEAVIN, F.R.M.S., F.N.P.S.



*Fig. 1.—Philatelic Microscope mounted in socket on side of containing case.*

**ITS PURPOSE.**

Philatelists have hitherto used small pocket magnifiers for the examination of their stamps. By comparison with the information obtainable with Watson's Philatelic Microscope this is infinitesimal. With the Microscope both watermarks and the texture of the paper used in the manufacture of postage stamps stand revealed, while it is of great educational value for examining forgeries, cancellations, overprints, etc., etc. Further, permanent records can be taken by photography or drawings of the special features observed. The illustrations given by Mr. Cheavin in his lectures and in his numerous articles on the Microscope in *Philately* have made manifest the variety of valuable purposes to which the instrument can be put—uses which increase in variety as the possibilities of the instrument are understood and appreciated.

The use of the Microscope is not limited to postage stamps, it can also be employed for ordinary observations of Natural History subjects.

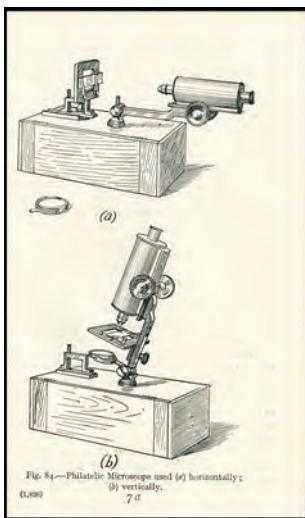

FIGURE 2. Watson Philatelic Microscope.

In a 1912 paper at the Royal Philatelic Society, London, he also discussed the use of photography, and warned of possible danger in some examination practices, such as the use of benzene for watermarks. He also touched on higher magnification and photomicrography, the process of taking photos through the microscope. Not surprisingly, the photos were made using a bellows camera and ground glass focusing, along with exposures of up to 20 seconds on glass plates.

In 1930, Cheavin gave another paper at the Royal in which he dealt with fluorescence, the transfer of postmarks when used

stamps were put face-to-face with unused, and what may well have been the earliest use of ultraviolet photography of stamps. He mentioned a paper on UV use that had been written in 1926. Cheavin's work with a quartz lamp that he had rented for only for three weeks gave us a cautionary tale for today. He stated "The details of the photographic exposure and treatment are reserved by the writer on account of the great expense entailed in this experimental work." [LP, Nov. 1930, p. 267.]

Cheavin's final paper at the Royal in 1946 was titled "Philately and Scientific Methods." He commented on a published



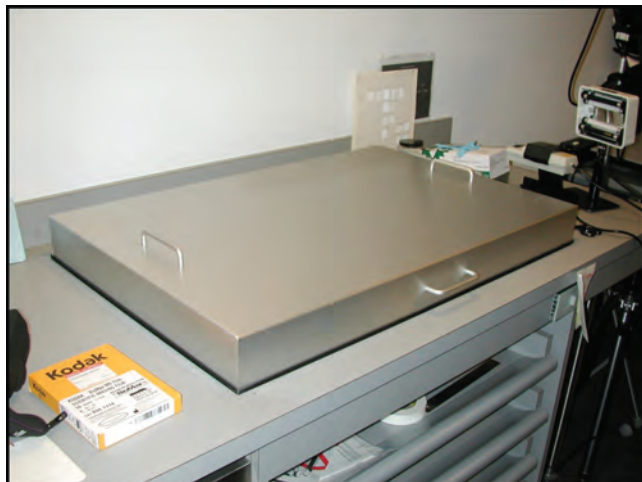

FIGURE 3. Beta Ray Equipment at the Morgan Library and Museum, New York City.



FIGURE 4. Results from a Beta Ray Analysis.

report that discussed John N. Luff's scientific equipment, the extent of which had been revealed only a few years before. He mentions that in 1940 the APS expert committee had been dissolved, which is not well known today. The most interesting thing he wrote about, however, was the most frustrating. He gave tantalizing bits of information about his progress using X-rays and beta rays, but without giving any details, showing only the results. Apparently he tended to keep his techniques to himself, and not share them with others.

The remarks after the 1946 talk involved H.R. "Bob" Holmes, one of the world's great experts at that time, who questioned the usefulness of expensive equipment to do what could be seen by the trained eye. The discussion was apparently quite lively, as Holmes was not one to hold back on his opinions.

I first read about Cheavin's beta ray use in a Robson Lowe monograph that included an illustration by Cheavin of the watermark of stamps on a cover front. This would obviously be an important tool to use on delicate covers, and I mentioned it

to Ron Lee at the RPSL expert committee in 1968, the year Cheavin died. Ron told me the little he knew of the process. I looked for a way to replicate what Cheavin had done, but was not able to do so until more than 40 years later.

Jumping ahead momentarily to 2011, in the interest of continuity, I finally managed to find a source of beta rays to use for examination, and did a successful preliminary run imaging the watermarks of stamps on cover (Figs. 3 & 4). With the promise of other uses, such as imaging difficult-to-see watermarks on loose stamps, I made plans to expand on its capabilities, but those plans were delayed due to other activity. For the 60th anniversary meeting of the AIEP, I assembled enough for a talk on my earlier results, and that attracted a lot of attention. I've been planning an article on the use of beta rays, adding some fresh examinations, and it is now progressing for publication next year.

Cheavin could have been a legendary name if he had been more open to helping others use his new tools, but he left only the idea that it could be done.

The lesson here: Share, or it might take decades to rediscover it.



## 1950 TO 1980

That's what passed for high tech in the first half of the twentieth century. It wasn't much, but a magnifying glass, perf gauge, watermark fluid and UV lamp was all that most philatelists seemed to need.

Some of us used photography, which was one of my main pursuits. In the early 1950s, I bought the finest camera equipment I could find, a Leica M-3 and all its close-up attachments (Fig. 5). The Kodachrome slides I was able to take at 1:1 were remarkably sharp and I enjoyed projecting them on a screen where the stamp might appear to be six feet high. I was amazed at how easy it was to see the finest details for example flaws and retouches of a stamp.

I worked with filters to enhance or suppress colors, and used ultraviolet illumination and infrared film to see features that were out of range for human eyes. The equipment is still some of the best around, even though digital cameras have made film all but disappear.



FIGURE 5. Leica M-3 camera and stand.

One philatelic photographic discovery was serendipitous. I had been asked to photograph a major collection in color, and chose to use daylight Kodacolor film with blue bulbs in order to get constant illumination. Some responses to that combination were remarkable, which led me to see what would happen if I shot the 4c blue Columbian error of color with the ultramarine normal and a faked blue.

At the Philatelic Foundation, we had been conducting a long, not very conclusive evaluation of a slightly different Columbian 4c blue (Scott 233a), which had both its backers and deniers. The photo I took put the discussion to rest (Fig. 6). The blue of the 1c and the two 4c color errors showed as blue, while the 4c ultramarine and a faked blue looked decidedly purple. As a result, the “new” blue was accepted.

The enlargements we get using photography are now routinely handled by high resolution scans, and are available in a few minutes rather than days. Other experts, who were early users of photography such as the expert Max Hertsch

of Switzerland, worked with advanced photographic techniques, but in his case, it was mostly confined to his expert work than shared with others.

I found working with UV, for example, helped to identify regumming, filled thins and chemical cleaning when those couldn't be seen normally. Similarly, infrared photography was useful for parts of repainting of stamps and cancellations, again, where they were not obvious. In general, expert work on difficult case involved time, the extra expense of setting up the photo, and waiting for the results.

That expense, however, was much smaller than some other techniques. Although we were aware that some highly specialized tests might be able to provide answers we couldn't get anywhere else, use of major equipment at universities and nuclear facilities required special cases. Sometimes these were justified, with the owner willing to pay for the extra costs.

This, however, led to an interesting abuse. A former employee of a major expertizing house created what turned out

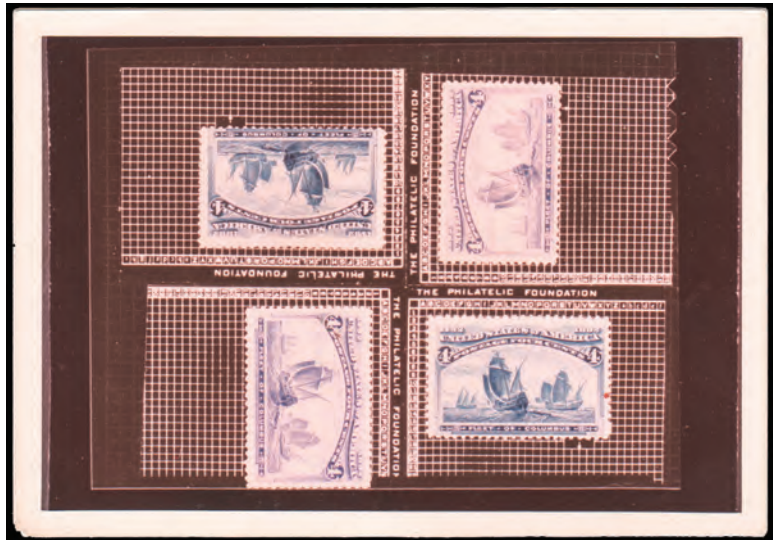

FIGURE 6. Original 233a (Upper Left), Normal Ultramarine 233 (Upper Right), Ultramarine Faked to Appear Blue 233a (Lower Left), New 233a (Lower Right).

to be a cottage industry in providing certificates of genuineness for stamps that ultimately turned out not to exist. He obtained spectrophotometry and X-ray printouts from a university professor who may not have known what was being done with them. He sold the printouts to the buyers of the stamps, interpreting the squiggles on the paper as identifying the proper characteristics of the supposed variety. In some cases, he used the same printout for more than one sale to different customers. A later expert performed tests that determined that the paper involved in the stamps was due to nothing more than dirty water, and was not specially formulated. The variety was removed from the catalogue. The principal involved is no longer alive.

The lesson to be learned here is that most philatelists do not have access to the expensive testing equipment and, more importantly, lack the ability to interpret the results of the tests.

**ARRIVAL OF DATABASES**

The advent of personal computers, with all their programs and attachments, brought technology to the masses. Database programs eliminated the use of cumbersome index cards and permitted interesting sort sequences that would have taken hours using paper methods. Scanners replaced photography, at least for recording images. Some programs allow both to be combined, which is a massive improvement over the 3 x 5 cards, or the InDecks cards used in the 1940s or before (Fig. 7). The latter allowed the user to sort through large sets to find related information. Creighton Hart used them for his study of the 1847 issues, as did I for my research on early Samoa covers.

Sophisticated as the card system was, electronic databases are immeasurably faster and far more flexible. I had constructed one to use also on the 5¢ imperforate of 1856, with input from Fred Mayer and the Levi records of known covers. Database



FIGURE 7. Access Database Screen.

construction is an art, but once done, it has powerful applications well beyond what one could do with an Excel spreadsheet. In particular, sorting with different sets of criteria can give an instant view that may display things that just do not belong. For example, sorting on a field that contains a French arrival mark could show the year date assigned to a cover was too early or too late. It was also evident from the data that some covers were fakes. Discovering these before the use of a database would have been much more difficult.

A major database development was the need to write a code that would show the position of stamps on the covers. With a number of them in the census, taken from different sizes and types of images, it needed to account for those differences. The code helped to eliminate a number of duplicates where only a portion of the cover had been illustrated, saving a lot of time over manual methods.



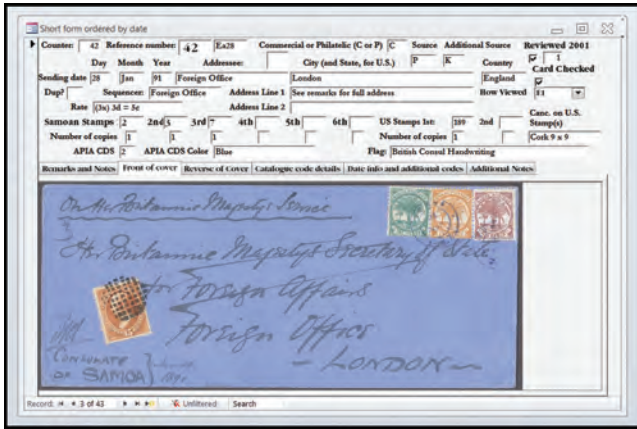

FIGURE 8. Access database with cover.

Another database shows the extent of the information that can be captured, used for analysis, and preparation for publication. I first recorded dates, names, other details about nineteenth century Samoa covers starting about 1975, using InDecks sorting cards. Those cards had double rows of holes around the outside, with the ability to use a notching tool to cut away the card to the first or second level, according to a numeral code. They were sorted by inserting a skewer into the appropriate holes and letting the “positive results” fall from the deck, and those could be further sorted. It was crude and slow, but it worked.

The image shown on the screen is information packed, and the bottom portion has space that can be used for different purposes, by selecting one of the tabs above it (Fig. 8). The first tab gives room for remarks and notes, while the second and third show the front and reverse images of the cover, respectively. These two images could be the result of a sort of over 1,000 known covers of the era, for any with U.S. 15¢ stamp (Scott 189) as part of the postage. The subset of those covers could be prepared in a few seconds using the database.

Similarly, the full set could be shuffled and sorted by date, last name of the addressee, type of cancellation, or just about any combination desired. It's always possible only one out of 100 sortings would yield new discoveries, but imagine if a researcher managed to do 75 using paper techniques without success, and gave up due to the lack of time available to continue. Both of the databases shown here yielded significant new information, and the Samoa database was reproduced in my book *Stamps and Postal History of Nineteenth Century Samoa* published in 2005.

## retroREVEAL

Another computer-driven system with promise is the use of high powered programs to manipulate scanned images. Color sampling has inspired a number of users to try to analyze the age-old question of shade determination. My own study in that field proved to be inconclusive, with too much variation even

in a single stamp to be able to make definitive statements. Perhaps someday a technique will be developed to give results that are confidently repeatable, which is essential in scientific analysis.

Other uses, however, are much more promising. The free online program retroReveal has a great deal of power to separate different component colors and marks of stamps and covers (Fig. 9). Starting with a high resolution scan, the program almost instantly breaks it into over 50 separate images, which are viewed side-by-side in groups of three. Some eliminate cancellations, while others show only the cancellations. It is particularly useful when a re-entry or type-identifying feature of a stamp is under a cancellation. It's most fun to work with when you have no idea of what you may find; the revelation can be powerful. It is very useful for expertizing and to generate top-quality illustrations for articles and books.

One can only wonder what Cheavin would have thought of retroReveal.

## 1980 TO 2015

Closing in on the end of the twentieth century, we found that occasional use of very expensive equipment could offer valuable results for expert work. Some of these examinations may have been available at little or no charge, but the bad news was that they often required a wait for “idle” time on the scientific equipment. One such example involved examining a cover to see if the ink of the tying cancellation was the same as that on the stamp. If the part on the stamp and the part on the cover had obvious differences, the likelihood was that it was a fake. The equipment needed was at the Metropolitan Museum of Art in New York, and used X-rays in an evacuated chamber. The Museum expert on the scene, not knowing much about philately, had no question the two inks were of different chemical composition.

Which brings us to more modern times. Major philatelic organizations, such as the Smithsonian National Postal Museum (NPM), the Royal Philatelic Society Experts, The Philatelic Foundation, The Vincent Graves Greene Foundation, and the American Philatelic Society have recently acquired sophisticated scientific devices that can be used routinely in examination of stamps and covers. In the case of the NPM, these are available for the public by appointment, but policy does not allow the Museum to make any conclusions. Sufficient data is presented for those doing research to make their own determinations and to share with expert committees.

Interpreting results can be a challenge for those who use these new devices, and in some cases it may take a trained expert to tell whether a difference is significant or simply sampling noise.

One major use of sophisticated equipment was the analysis of the Grinnell Hawaiian Missionary stamps. The person who created the fakes used convincing materials, but had only the knowledge of the issues that was current at the time to use in their fabrication. Since two different types were known, they had arbitrarily been identified as Type I and Type II. In the absence of any known multiples, the Grinnell creator used Type I to the left of Type II, but a later discovery found the opposite to be correct. That was only one of the mistakes, but a serious one.



FIGURE 9. Results from retroReveal.

The final nail in the coffin was more interesting. Various cancellations were found on the Grinnells, all in black, with a circular example that had horizontal stripes, and was nicknamed the “Jupiter.” In looking through the Grinnell holdings, we were amazed to find two genuine Missionary stamps, one of each type. One of these had the Jupiter cancellation, but Raman spectroscopy showed that the ink of that cancellation was aniline based, not the same as the carbon black ink on the Grinnell copies, but the cancellation was identical. Since aniline was not developed as a dye until years later in Germany, it was obvious that the black was not the same black when looked at with modern equipment. I believe that these two genuine Missionary stamps had been the basis for the fakes, and that the Jupiter had previously had the more normal pen cancel. The Jupiter was added to give the others “respectability,” but turned out to be the smoking gun.

### SO WHERE DOES THIS LEAVE US?

We can break analysis into two types: those where the results are obvious, such as high resolution measurements and image manipulation to enhance features, and those that require skilled interpretation, such as X-ray fluorescence and Raman spectroscopy.

In the case of the former, at the basic level, we still have our pocket magnifiers, watermark fluid, perf gauges and UV lamps. Along with a good reference collection and library, these are likely to be our prime resources, as they were in the past. Moving more into the present, we have the use of scanners and computers, along with powerful programs such as Photoshop, databases, and on-line programs like retroReveal, to extend our ability beyond the tools of the past. Those are all available to the seasoned researcher, and do not require a great deal of

sophisticated knowledge to use them to good effect. They are very useful for research beyond confirmation of genuineness and manipulation.

For the second category, we are facing a new present, where we have sophisticated tools such as X-ray fluorescence, Raman spectroscopy and the VSC-6000 that have the potential to reveal the elemental components of inks and shades under different specialized lighting conditions. We should be hearing a lot more about these in the next two days.

And as nice as those may be to contemplate, they trouble me. I've used advanced tools since the early 1950s, and feel very comfortable with most of the new ones I encounter. With an idea of what they can do, I can often see applications that would help solve a problem that might have once been considered impossible. Yet I remain very much aware of the limitations on my own ability to interpret some of the results from the highly sophisticated equipment. Often it takes a trained professional to understand whether the observed data may be significant or not.

If the results from two printouts show what is incontrovertibly a difference between two observations that should be the same, fine. But how close can those differences get and still be reliably different? What is the possibility that the samples

contain other elements that may make things look different? To the average technically-minded observer, two printouts may seem identical, while to trained analysts they may differ significantly. In my way of thinking, that can cause problems.

We should welcome the use of new equipment and techniques, but with caution. If the scientific methodology used is, of necessity, limited to a few samples, or if interpretation demands a highly trained expert analysis, we should keep our minds open to the possibility that things may not be quite what they seem.

And finally, I believe that any highly sophisticated examination should be repeatable. Fortunately, this is made less of a problem as the different devices become installed in a number of locations, some of them available on appointment. For cases in which differences are obvious, this can be useful. Nevertheless, it is the final interpretation of difficult or ambiguous cases that often requires expert attention that becomes the weak link.

So my message today is that technology can be useful, and can add major tools to our bag of tricks as we investigate small bits of paper. Almost as important is the value of sharing information and techniques. As long as we can do that, with knowledge of technology's limitations, we will contribute to the advance of philatelic study.

# Paper and Color Varieties of the People's Republic of China “Workers and Soldiers” Definitive Set of 1955-1961

*Archie McKee*

---

**ABSTRACT.** Paper thickness measurements, X-ray fluorescence, and color spectra comparisons were used to differentiate a People's Republic of China set of definitive stamps with one distinguishable variety. The scientific methods described in this paper demonstrate both paper varieties and different ink formulations within the various denominations.

## INTRODUCTION

After many years of conflict, the establishment of the People's Republic of China (PRC) in 1949 was one of the 20<sup>th</sup> Century's most significant moments. Getting such a vast country operating efficiently and smoothly, after such a tumultuous period, posed tremendous challenges to the authorities, one which was the postal service.

In 1949 the PRC was still struggling on many fronts. China had been in serious turmoil since the collapse of the Qing Dynasty in 1911, and, some would argue, since contact with the West in the mid 1800's. Turmoil continued with ongoing political campaigns (Anti-Rightist Campaign 1957-8), The Great Leap Forward 1958-1961, society-changing land and business reforms, campaigns aimed at solidifying Mao's hold on power, the Korean conflict, and an economic embargo by the West, to name a few.<sup>1</sup>

For many years, the author wondered why there were so few varieties and errors in early PRC philately listed in catalogs. The lack of serious study of this period due to political positions, both inside and outside China, may in large part account for this. The author also doubts all stamps of this set were printed in one location at one time. Usually definitive stamps are printed multiple times over the life of the usage.

For quite some time, what are believed to be varieties has been noted, but there is a lack of any literature references on which to base this. A survey of English language literature (The China Clipper, Journal of Chinese Philately, The Great Wall, China Philately, and Chui's Supplement) added little. The very idea of a stamp “variety” was not well defined in the philatelic community. With the creation of the Institute for Analytical Philately (IAP) in 2010, a way to analyze and document these supposed variations or varieties in an objective and technical manner emerged.<sup>2</sup>

Chosen for this study is the Yang R8 set of definitives, Scott PRC # 273-281, Stanley Gibbons China 1646-1652, the Peasants and Soldiers Regular Issue of 1955, as seen in Figure 1. Reasons for choosing this set are it:

1. Is somewhat inexpensive and readily available in quantity
2. Was used for an extended period of time, 1955 to 1961
3. Has only one known variety listed in the literature
4. Was issued and used during trying times
5. Was printed by lithography (most likely stone) on un gummed paper.





FIGURE 1. Yang R8 set of stamps.

Paper thickness summary by denomination  
Yang R8 set, Scott PRC 273-281

thickness	1/2 fen		1 fen					2 fen		2 1/2 fen		4 fen		8 fen, Beijing		10 fen					20 fen		50 fen				
	O	T	O	Y	T	N	N,Y	O	T	O	T	O	T	O	T	O	O,Y	T	T,Y	N	N,Y	O	T	O	T	N	
0.0024								1																			
0.0025															2												
0.0026							3	3		1					2												
0.0027							5								1	1		1	1				3	2			3
0.0028			5	1									5	1	1								1	7			
0.0029			4										2										2	7	4		
0.003			5	1									1	1									2	2	2	4	
0.0031			4																								
0.0032			1																				3	11	3	1	5
0.0033			1																				4	2	1	2	2
0.0038			2																				1	3	5	1	4
0.0034			1	3																				2	1	3	
0.0035			2	3																			8	2	1	2	12
0.0036			7																				1				5
0.0037			1																								
0.0038			3	1																							
0.0039			7																								
0.004			3																								
0.0041																											
0.0042																											
0.0043																											
0.0044																											
0.0045																											
0.0046																											
0.0047																											
0.0048																											
0.0049																											
0.005																											
0.0051																											
0.0052																											
0.0053																											
0.0054																											
0.0055																											
Total	44	10	5	7	9	6	29	18	44	56	30	29	19	14	4	16	4	9	23	4	12	36	41	22	15	44	

TABLE 1. Paper summary.

The set is composed of nine denominations with the single listed variety of the Shanghai printing of the 8 fen orange, perforated 12.5 as opposed to 14 for all the Beijing printings (Scott 278a, Yang R59, SG 1650a).

This study will focus on two factors: Paper and ink (color).

## PAPER

With the withdrawal of Soviet troops from Manchuria at the end of WWII in late 1946, much of the manufacturing industry in that area was seized and shipped to the USSR. The PRC faced immediate challenges getting its heavy industry (including paper manufacturing) back up and running after

decades of conflict. Due to this, it is assumed some paper differences exist in this set.

The investigation was limited itself to either cancelled-to-order (CTO) or mint stamps, as used stamps, although analyzed initially, proved to be subject to excessive unremoved glue and residue affecting paper analysis. The first attempt at analysis involved the time-honored technique of holding a stamp by one hand and “flicking” a corner of the stamp with the other. Both sound and the force of flipping were considered, however this technique proved unreliable.

The second technique used was to soak the stamps in water and, upon drying, separate them into two main groups. While wet the first group showed opaqueness; the second group showed translucency. A few fell in a third group of neither



opaque nor translucent. The assumption was opaque stamps were on thick paper and translucent stamps on thin. This method also proved unreliable.

The third attempt relied on careful measurement of the paper thickness. A Mitutoyo Dial Thickness Gage #7326 hand-held micrometer was used, measuring to 0.0001 inches with a 1cm anvil diameter.

A data table, showing thickness frequency distribution of each issue of this set, is presented in Table 1.

Dard Hunter in his monumental book on paper,<sup>3</sup> estimated there were as many as 40,000 cottages in China “where paper was made in the traditional manner” at the onset of the Japanese invasion. The large range of thicknesses caused the author to consider the paper handmade. However, this turned out to be untrue. Three tests were performed on the paper to see how it was made. The first was to slightly dampen the stamp. A curl would be indicative of machine-made paper, which stresses the fabric as it forms on the press. The second test tore the stamp both up-down and side-to-side. If the paper was made by machine, the fibers would align and one direction would yield a straight tear, the other an irregular one. The third test examined the stamp by transmitted light. If machine made, a very light, tight line pattern formed by the wire web would be seen.<sup>4</sup>

All three tests proved positive for machine-made paper as can be seen in Figures 2 (curl), 3 (tear), and 4 (pattern).

Since the paper was machine-made, considerations were given to possible differences. It was noted earlier that one group of paper appeared opaque when soaked, and was very slow to absorb water. The second group was considered translucent and absorbed water almost as soon as contact was made. The third group appeared somewhat different in both opaqueness and speed of water absorption. The opaque paper was considered as treated with sizing; the translucent paper was considered as having no sizing added, most likely indicating they had been acquired from different sources or, at least, from different production runs. The third group appeared to have either little sizing added or some different treatment.

In 2015, on the 1 fen stamps, a fourth category was found. A group of stamps had developed a yellowish tint on the front surface, yet no yellow is seen on the stamp back. Figure 5 shows on the left, top and bottom are two stamps that have absorbed no water after fifteen (15) minutes. In the middle are two stamps that very quickly absorbed water. On the right are two stamps with the yellow color. (Unfortunately, the yellow color does not reproduce well).

No yellow had been previously recorded in any literature known to the author. One possible explanation may be the yellow is from a surface treatment which has aged with time, since no yellow is present on the backs. This color did not appear to come from a paper coating as there were paper fibers visible when the front surface was closely examined. This characteristic lead the author to consider this as a possible fourth paper type.

## INK OR COLOR

In 2014, a grey green shade of the 2 fen green was documented in McKee’s “The PRC R8 Definitive Set, Some Observations.”<sup>5</sup> Using almost 600 individual stamps in the set, an



FIGURE 2. Slightly wetted stamps curl indicating machine-made.



FIGURE 3. Stamps torn vertically and horizontally show characteristic patterns for machine-made paper.



FIGURE 4. Stamp photographed by transmitted light shows pattern from the wire web characteristic of machine-made paper.

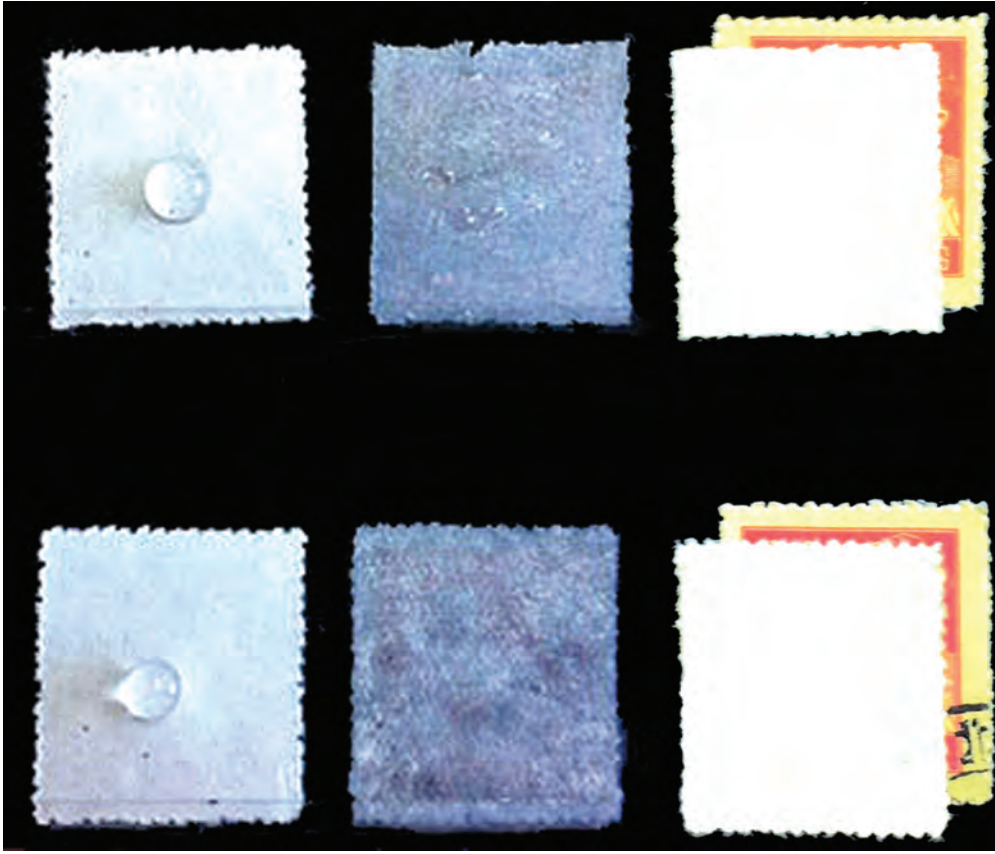

FIGURE 5. Six stamps showing three paper types.



FIGURE 6. Possible shade differences in the Yang R8 set.



additional three shades have now been documented. Two possible shades of four denominations were identified by visual means, and these are shown in Figure 6.

A personal computer, with Photoshop Elements 13, was used to sample three of each shade for their hue, saturation, and brightness (HSB) values. The HSB system is used to establish color values for images. The H-value, is what most would call “color” expressed as degrees counterclockwise from 0 (red) to 360 (red again) as in a circle. The S-value indicates purity of color and is expressed as a percent from 0 (gray) to 100 (fully saturated). On the standard color wheel, saturation increases

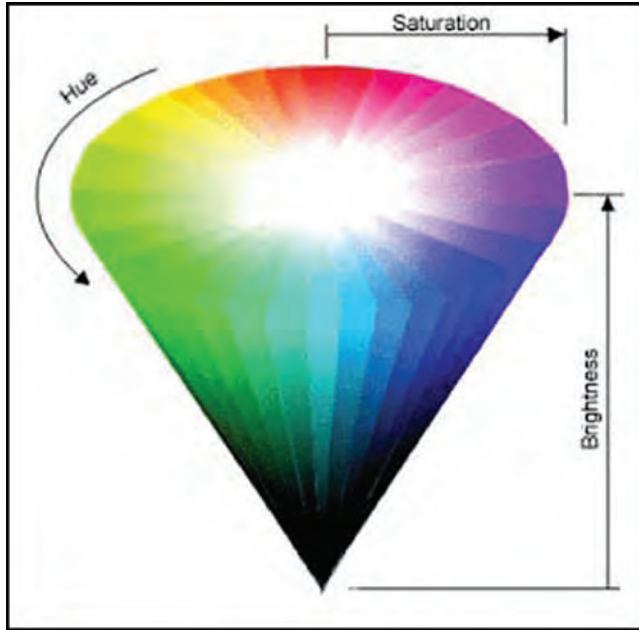

FIGURE 7. HSB color scheme explanation diagram.

from the center to the edge. The B-value is expressed as a percent from 0 (black) to 100 (white) from bottom to top and can be visualized as a cone as seen in Figure 7.<sup>6</sup>

Each stamp was scanned on an Epson XP-410 at 600 dpi, using Photoshop Elements 13. To be able to select a single pixel, the stamp image was then sampled by magnifying. Using the dropper tool, one of the darkest pixels was selected and the HSB data was displayed and recorded. This procedure was repeated three times in different image locations for each stamp sample.

Table 2 shows the results of this sampling. The H-value for the three samples on the left side are different from those on the right side. A percentage difference of the average H-value between the two shades is shown. The author believes this is a useful tool that can be used by most philatelists. Most current graphic software programs offer this feature.

The data shows the ½ fen, 2 fen, and 8 fen shades have a significant difference in H-values. The 1 fen average value is more closely aligned.

### VSC 6000

The subject stamps were tested at the National Postal Museum (NPM) in Washington, D.C. using the Video Spectral Comparator 6000 (VSC 6000) manufactured by Foster + Freeman, Ltd. of Evesham, Worcestershire, United Kingdom.

For each sample, a full range of reflectance data was collected, and the collection of reflected wavelengths from 400 nm to 1000 nm was acquired and displayed.

### X-RAY FLUORESCENCE

Each sample was also tested at the NPM, using the Bruker Tracer III-SD handheld X-ray fluorescence analyzer. The device uses a rhodium X-ray tube with a silicon drift detector that has a resolution of 145 kV and a spot size of -0.5 cm<sup>2</sup>. The spectra

HSB values Left hand stamps				HSB values Right hand stamps						
	1/2 fen brown value			Avg.	1/2 fen brown value			Avg.	% difference	
H	14	16	13	14	H	16	17	16	16	14.0%
S	47	55	51	51	S	60	63	53	59	
B	69	60	61	63	B	64	65	63	64	
1 fen violet value					1 fen violet value					
H	318	312	322	317	H	330	333	330	331	4.3%
S	40	44	47	44	S	47	49	41	46	
B	53	51	49	51	B	61	59	62	61	
2 fen green value					2 fen green value					
H	137	140	140	139	H	155	158	158	157	12.9%
S	52	52	54	53	S	18	20	23	20	
B	49	49	53	50	B	54	57	53	55	
8 fen orange value					8 fen orange value					
H	7	7	8	7	H	8	6	10	8	9.1%
S	75	69	71	72	S	70	73	79	73	
B	100	100	100	100	B	100	100	100	100	

TABLE 2. HSB Sampling Data.

## 1/2 FEN VALUE



FIGURE 8. ½ fen shades.

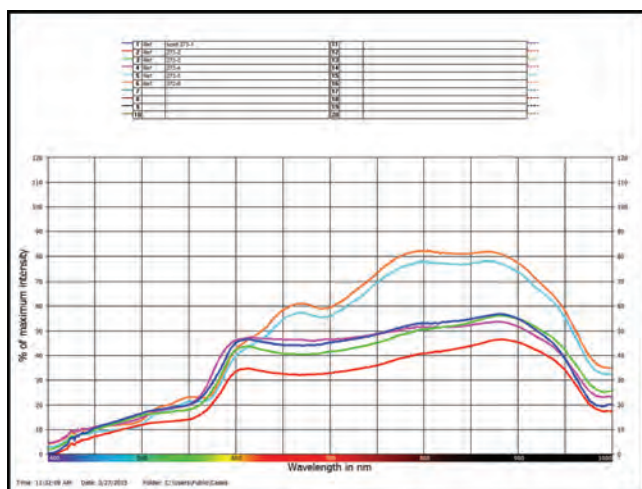

FIGURE 9. ½ fen VSC data.

produced were acquired at a voltage of 40 kV beam current of 6  $\mu$ A and live time of 180 seconds. The beam penetrated through the entire sample stamp.

Data from the Bruker device is displayed both in a graphical and tabular manner. Condensed table format shows the data for certain chemicals more clearly with a graph. Raw data is shown in the table on the left for each of the six stamps sampled, a graph of which is shown below the table. On the right side of the image is a second table of the averaged values for each group, and its graph is shown below the table.

The ½ fen VSC 6000 data is displayed in Figure 9. Brown, the basic color of the stamp, is located at about 650 nm. It appears samples 1-3 fall in one grouping (below), and 5-6 fall into another (above). Sample 4 seems to overlap more with the 1-3 group from about 625 nm and above.

The set was also examined using the Bruker Tracer III-SD. The data is displayed in Figure 10. Note the variation in values, which was unexpected.

The ½ fen values show significant differences in the amount of Cr and Pb used in each group. Cr is 27.8 times higher and Pb 112 times higher in samples 1-3 than samples 4-6. This extreme difference in concentration indicates different ink formulas were used when these stamps were printed. Given that different ink formulas were used, and visual shade differences were apparent, it can be said different ink variations were used to print the ½ fen denomination.



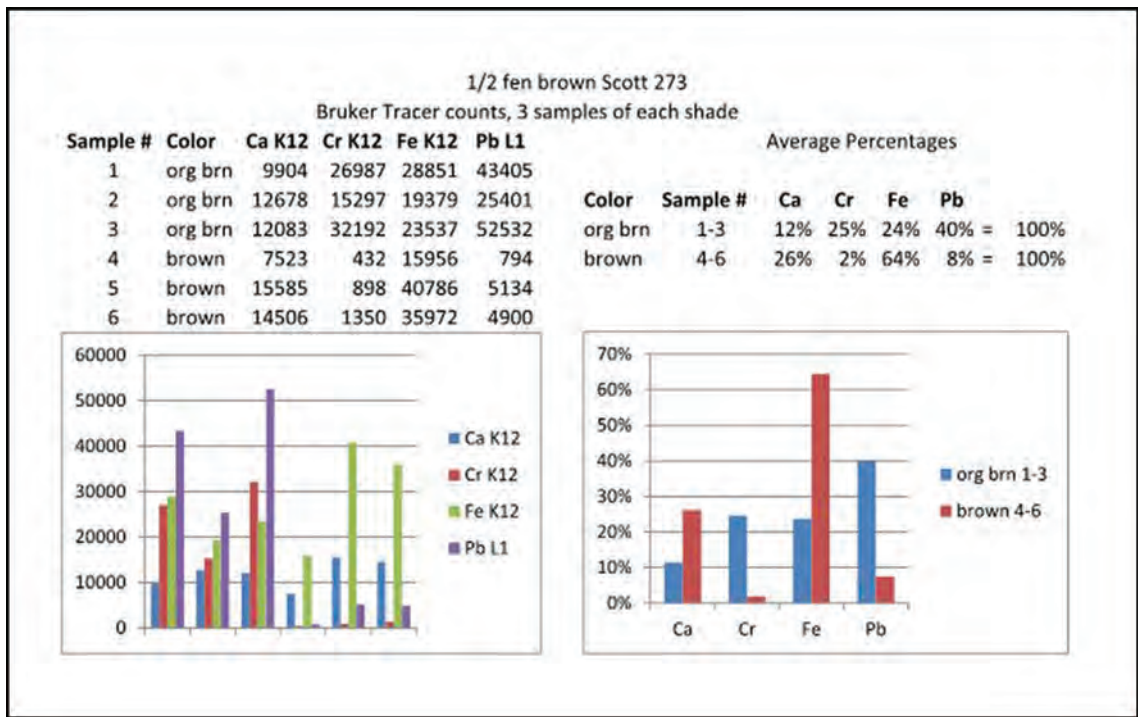

FIGURE 10. 1/2 fen Bruker data.



FIGURE 11. 1 fen shades.

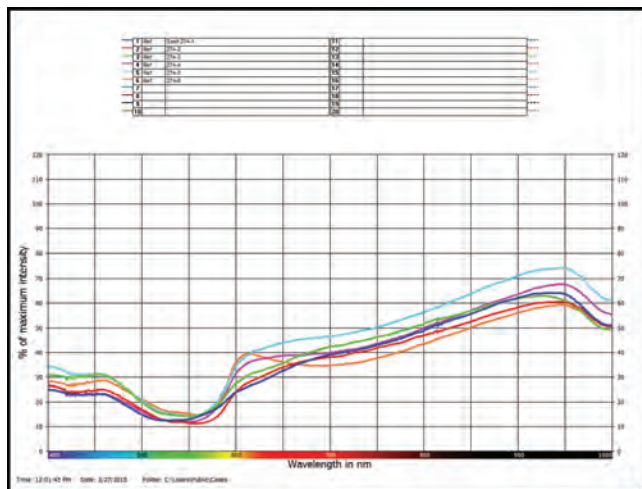

FIGURE 12. 1 fen VSC data.

### 1 FEN VALUE

The VSC 6000 data for the 1 fen is seen in Figure 12. The stamps could be described as purple, at about 400 nm. Note samples 1-2 are grouped at the bottom, and samples 5-6 are grouped above. Sample 4 is partially hidden behind 1-2 and Sample 3 is between samples 5 and 6.

When examined with the Bruker Tracer device, the data in Figure 13 was much closer in composition. Although the

averaged data for both groups was comparable, it is apparent there were significant differences between the Fe and Ca levels in individual samples.

### 2 FEN VALUE

VSC 6000 data for the 2 fen green is displayed in Figure 15. Green is in the 500-550 nm range. Note samples overlap

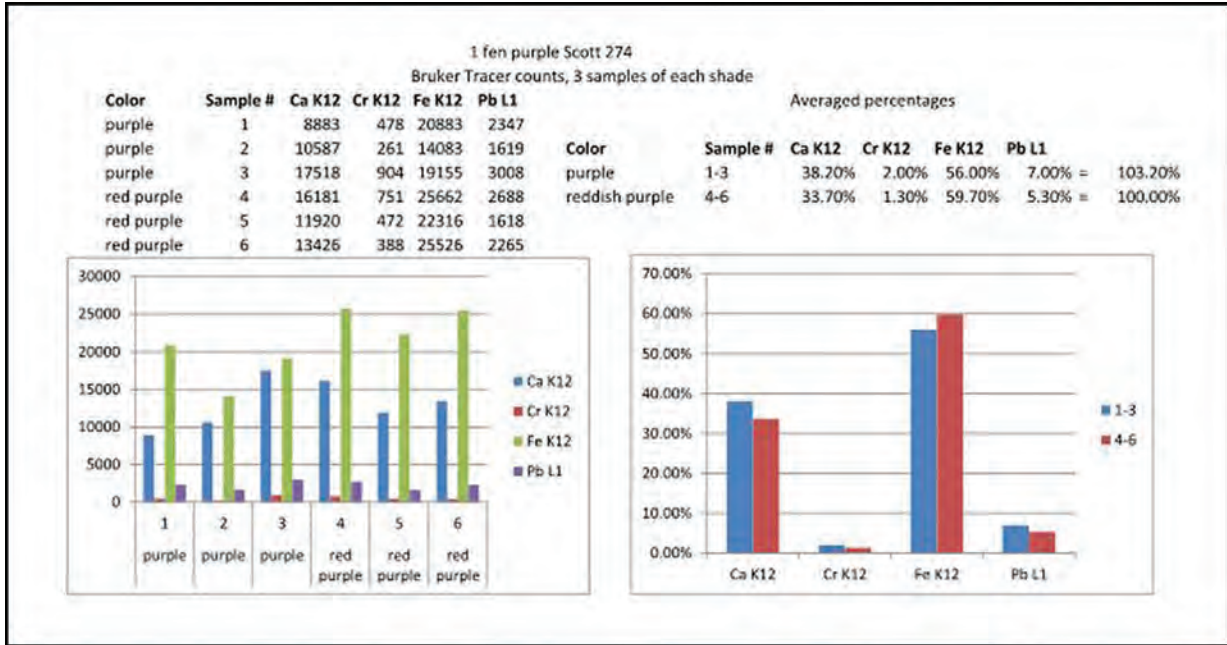

FIGURE 13. 1 fen Bruker data.



FIGURE 14. 2 fen shades.

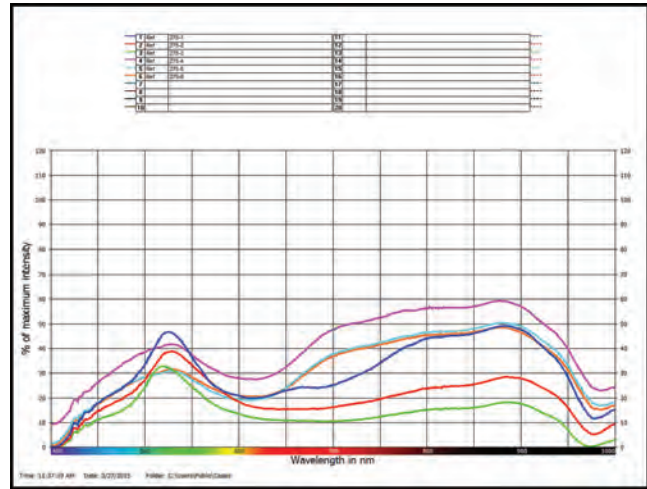

FIGURE 15. 2 fen VSC data.

extensively, but Samples 1, 2 and 4 seem to group, as do Samples 3, 5 and 6, in this wavelength range.

The Bruker Tracer data is displayed in Figure 16. Note the relatively low level of Cr in Sample 3, when compared to sample 1 and 2, and the large quantity of Pb in sample 2. Samples 4-6 seem to be fairly consistent in their chemical composition. It was very difficult for the author to believe the ink on stamps represented by samples 1-3 was not chemically different. It seems the two

different groupings were valid for those sampled, based on the averaged numbers.

### 8 FEN VALUE

The VSC 6000 data for the 8 fen orange Beijing print is displayed in Figure 18. Orange is found at about 600-650 nm. Again, Samples 1-2 group with Sample 4, and 5-6 groups with



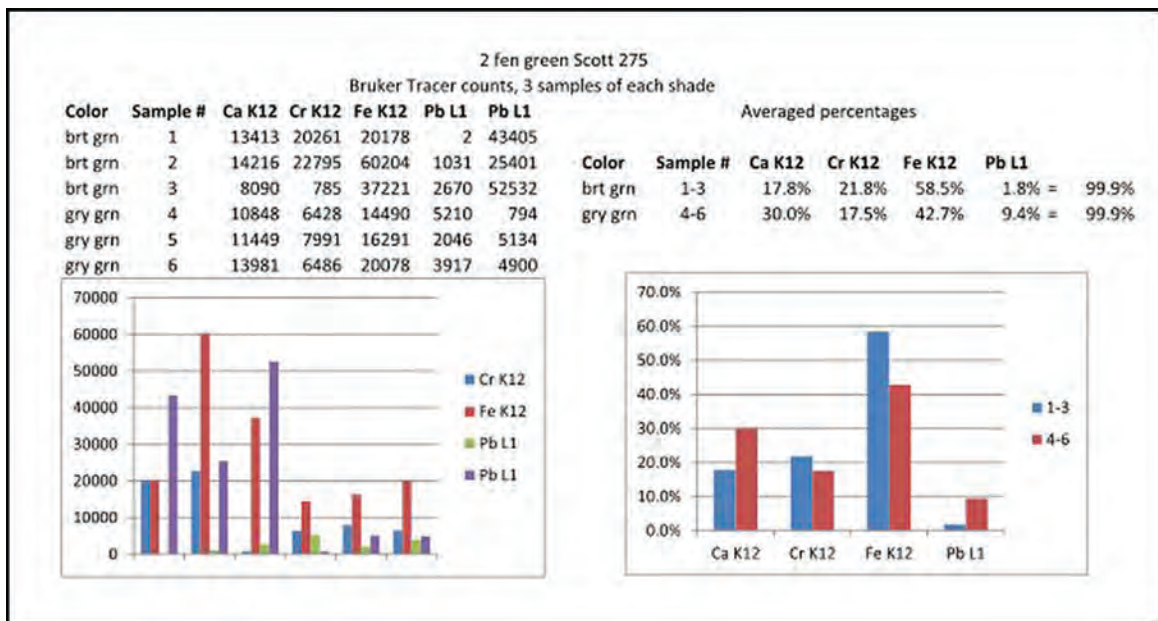

FIGURE 16. 2 fen Bruker data.



FIGURE 17. 8 fen shades.

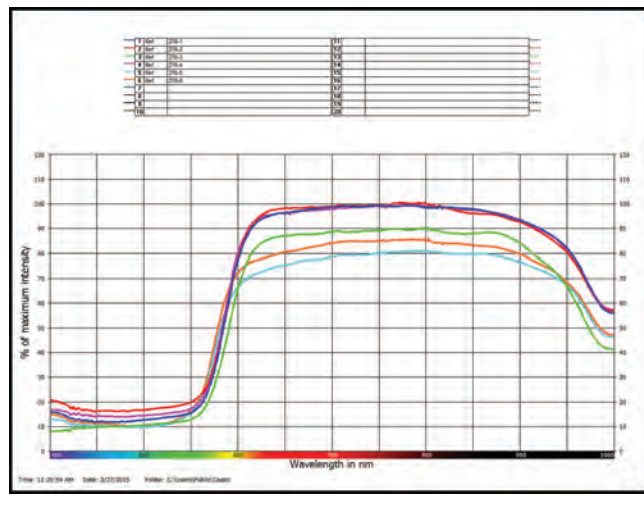

FIGURE 18. 8 fen VSC data.

Sample 3. It seemed strange to the author this pattern repeated itself on each denomination in this study.

The Bruker Tracer data displayed in Figure 19 also showed significant differences. Note the more than amount of Cr in Sample 3 compared to Sample 2. Also Cr was present in Sample 4, but negligible in 5 and 6; in fact, almost 60 times greater in 4 than 6. The averaged numbers in the second graph also showed significant differences in ink composition between the two groups.

## CONCLUSIONS

Authorities in China state there are no paper differences.<sup>6</sup> Analytical analysis shows there are four (4) different papers in the use of sizing, surface treatments, and paper thickness to name a few. The possibility of using different suppliers and/or different printings during the time period of use might help explain these differences.

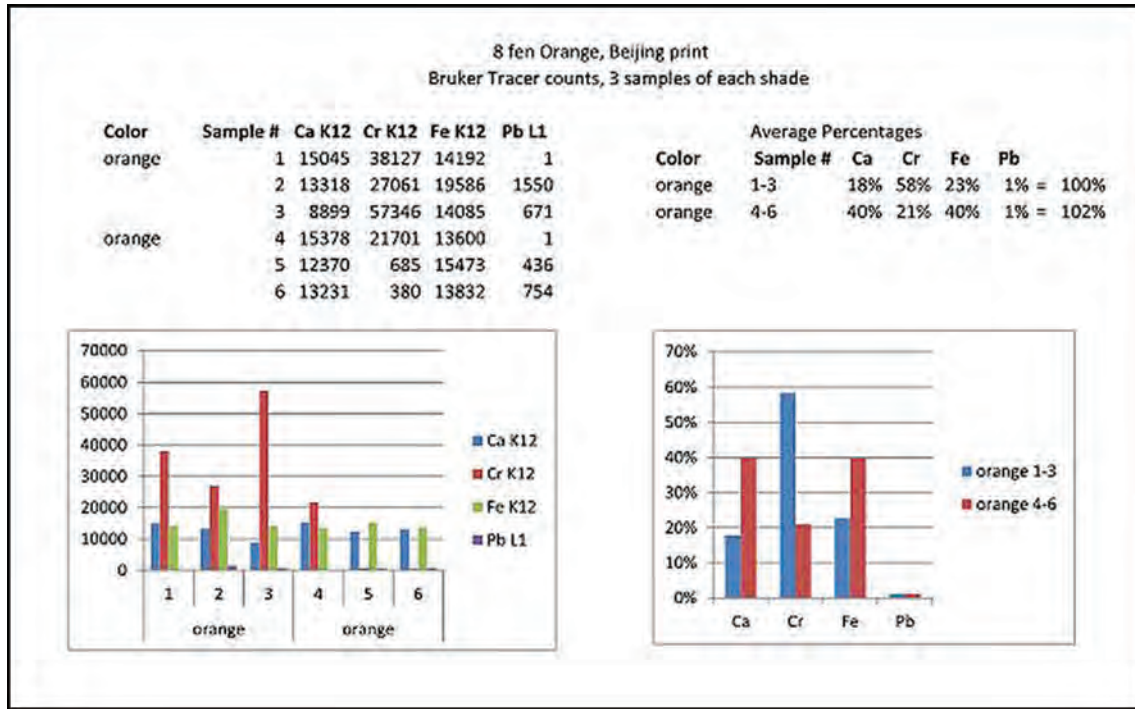

FIGURE 19. 8 fen Bruker data.

Authorities also state there are no color varieties. But ink differences were apparent in each denomination studied. There were differences in the chemical composition of inks resulting in different shades, but also differences in chemical composition in stamps that appeared to be the same shade. Few of the samples studied with the VSC 6000 seemed to produce duplicate reflectance data, thus showing shade varieties. The VSC 6000 also showed several instances where visually categorizing the stamps was not necessarily valid when sampled analytically. The trouble with color differentiation by visual means has been widely discussed in the philatelic literature as quite problematic. The conclusion thus seems to be that different ink compositions were used, and different color shades were produced. In this study, two shades of four denominations were documented.

The Chinese were faced with multiple challenges, and it is the author's opinion that they did the very best they could under difficult conditions with the materials available. But the authorities claim that there are neither paper nor ink differences do not stand the philatelist's analytical scrutiny.

How many total varieties are in this set of nine basic stamps is open to debate and discussion and remains for further study. At this writing, it would appear there were at least four different papers used, and four denominations which had two or more chemical compositions of the ink, resulting in different spectra and different visual color shades.

## ACKNOWLEDGEMENTS

The author is appreciative of following people: James Allen for his assistance on paper and inks, especially in the early stages when much appeared quite confusing. Robert Hisey, a highly respected Paper Engineer, in assisting understanding about paper and printing as this study went forward. Thomas Lera, Blount Research Chair at the NPM, and James O'Donnell who assisted the author during three trips to collect data for this study. The final VSC and Bruker data were collected by Thomas Lera. Without the assistance and encouragement of these individuals and the NPM and IAP the study could not have been accomplished.

## NOTES:

1. Shu Guang Zhang, 2001, *Economic Cold War: America's Embargo against China and the Sino-Soviet Alliance, 1949-1963*, Woodrow Wilson Center Press.
2. Herendeen, D.L., James A. Allen, and Thomas Lera, 2011, Philatelic Shade Determination Based on Measured Color, *London Philatelist*, Vol 120, (1384).
3. Dard Hunter, 1978, *Papermaking, The History and Technique of an Ancient Craft*. Dard Hunter, Dover reprint 0-486-23619-6.
4. Hisey, Robert, Paper Engineer and recognized authority on papers and inks. Personal communication. (2015.02.28 and 2015.12.02)
5. Archie S. McKee, 2014, The PRC R8 Definitive Set, Some Observations, *The China Clipper*, Vol 79, No 1.
6. "Color tutorial - HSB - TomJewett.com" [www.tomjewett.com/colors/hsb.html](http://www.tomjewett.com/colors/hsb.html) accessed December 28, 2015.



## REFERENCES:

- L.N. Williams, *Fundamentals of Philately*, American Philatelic Society, 1990, 0-933580-13-4
- The China Clipper*, China Stamp Society
- Journal of Chinese Philately*, China Philatelic Society of London
- Chiu's Supplement*, C.W Chiu, Hong Kong, China
- The Great Wall*, China Philatelic Society of Sydney, Australia
- China Philately*, All China Philatelic Federation, Beijing, China
- Scott Standard Postage Stamp Catalogue*, Vol 2 C-F, Scott Publishing Co., 2012
- Stanley Gibbons Stamp Catalogue*, Part 17, China, 8th Edition, Stanley Gibbons, Ltd, 2011.
- Yang's Postage Stamp Catalogue of the People's Republic of China, Part II 15th Edition*, Yang's Philatelic Trading Co., 2009
- Proceedings of the First International Symposium on Analytical Methods in Philately*, edited by Thomas Lera, John H. Barwis, and David Herendeen, Smithsonian Institution Scholarly Press, 2013
- Zhang D. T., 2002, What About the Light Green Stamp, *The China Clipper*, Vol 66, No 5.
- VSC 6000: <http://www.fosterfreeman.com/questioned-document-examination/235-vsc-6001.html>
- Bruker Tracer: <https://www.bruker.com/products/x-ray-diffraction-and-elemental-analysis/handheld-xrf.html>



# The Admiral Issue of Canada: A Colorimetric and XRF Study of the Carmine 2¢ Issue

*Richard H. Judge*

---

**ABSTRACT.** A study of the 2 cent carmine stamp of the Admiral Series of Canada using reflectance and X-ray fluorescence spectroscopy is presented. About 693 unused stamps were analyzed in an attempt to group the various shades according to the Scott and Uni-trade<sup>1</sup> catalogue listings. Reflectance spectra were reduced to both CIELAB values and a set of parameters based on the Munsell Color System developed by Romney. A near continuum of values is obtained in both systems. A third system of classification, based on the analysis of the slope of the reflectance curves in two separate wavelength regions, allows for a strong grouping into rose-carmine and carmine shades. It also shows that an aniline ink variety is readily identifiable and, in certain cases, correlates with the pink shade (Scott 106b). An XRF analysis of the complete set of stamps identified Ca, Ba and Pb as the prominent elements present in the ink. The less prominent elements Fe, Cr and Mn are observed. Zinc, a critical element, is present in high amounts in the rose-carmine shade and is absent, or nearly absent, in the carmine shades. An important criterion for the classification of the aniline ink pink shade is the lack of Zn in the ink formulation of these stamps, even though pink is considered a shade within the rose-carmine earlier printing.

## INTRODUCTION

The color and, to a greater extent, the shade, of a stamp is a difficult concept to define quantitatively. A collector's perception of a stamp's color will vary markedly from individual to individual and is due, in large part, to the physiology of human vision. In addition, there is also a general disagreement amongst philatelists in assigning names to color hues and shades. This, coupled with the older technology of color matching used in the printing of stamps in the late 1800's and early 1900's, has lead to a somewhat arbitrary and confusing classification of stamps based on color. The identification of the color varieties of an issue, in the absence of spectroscopic data, needs to rely on additional information such as paper types, printing year and watermarks in order to conclusively link an individual stamp with a particular catalogue number and shade.

One would think the science of colorimetry would be able to aid substantially in rectifying this situation. To a large part, this is indeed the case. One important instrumental method of colorimetry is diffuse reflectance spectroscopy. This method relies on illuminating the surface of an object with white light, followed by the gathering of the light reflected from the surface of the material. The reflected light is then dispersed based on its wavelength (color) and the dispersed spectrum is displayed as a plot of wavelength versus intensity. Light that has been completely reflected without absorption by the material is assigned an intensity of one (1). A wavelength that is completely absorbed is given a value of zero (0). Figure 1 shows a typical reflectance spectrum of a rose-carmine, carmine and a pink stamp.

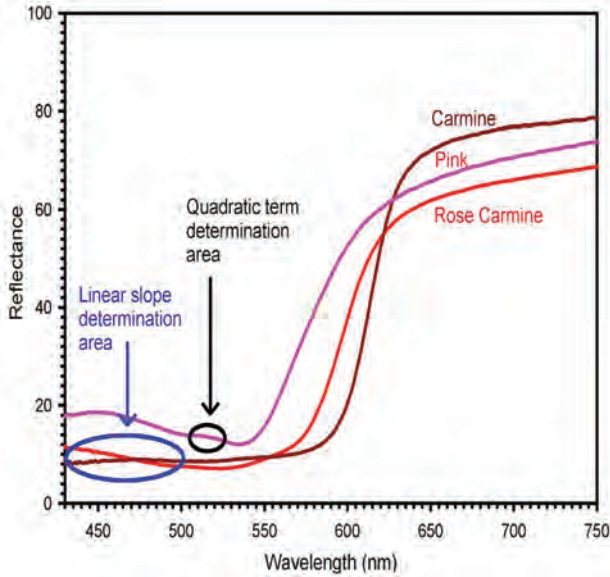

FIGURE 1. Typical reflectance spectra of a rose carmine, pink and carmine stamp. The difference in linear slopes, indicated by the blue ellipse, clearly shows the characteristic feature that differentiates rose carmine from carmine stamps. The black ellipse shows the small rise in reflectance characteristic of the pink shade and is absent in the other two shades.

As stated by Herendeen, Allen and Lera<sup>2</sup>, investigators have used diffuse reflectance spectroscopy to authenticate individual stamps and conclusively identify forgeries and fakes. However, the use of colorimetry to *classify* shades is not as definitive. Herendeen et.al. show there is substantial variability in the translation of an observable reflectance spectrum and its quantitative mathematical treatment to the assignment of a shade to a particular copy.

It is the intention of this paper to extend the investigation of Herendeen et.al.<sup>1,2</sup> to the ‘Admiral’ Issue of Canada. Several methods of classification will be developed and described but, ultimately, only one method can be used to give a definitive determination of shade.

### THE ADMIRAL ISSUE:

On the death of King Edward VII and the coronation of George V of Great Britain in 1910, Canada produced a series of definitive stamps showing King George V as the ‘Admiral of the Fleet’. The series ended in late 1928 with the issuance of the ‘Scroll’ series, although the monarch was still depicted in his admiral’s uniform. A 3¢ ‘Admiral Provisional’ made a brief appearance in June of 1931. Because of the series’ long run, numerous postal rate changes, UPU (Universal Postal Union) stamp color directives, the shortages caused by the First World War and printing technology changes, the Admiral series is rich in content and varieties. This paper will investigate the 2¢ carmine issue, extending from Dec 22, 1911 to 1925. The reflectance study is subdivided into three main sections. The error range of the study is tested through two tests: (1) the repeated analysis of a single stamp over a specific, fixed region of the stamp with readings taken over a two year period and (2) the analysis of different areas of the same stamp. The latter will illustrate the variation of the spectroscopic parameters with ink density (see below). Finally, the data from approximately 693 stamps will be analyzed for a discernable correlation to the current accepted shades for this issue. All stamps were mint stamps, some without gum. In addition, a data set from nearly 50 plate blocks is used to add a time element to the investigation. Finally, X-Ray Fluorescence (XRF) spectroscopy will be used to identify the elements present in the ink and will be used in conjunction with the reflectance data to allow for confirmation of the shade assignments.

### EXPERIMENTAL METHODS:

The reflectance spectra were recorded with an Oceans’ Optics USB4000 UV-VIS spectrometer with an approximate resolution of 1.5nm and dispersion of approximately 0.15nm per pixel. Digital processing was performed by the SpectraSuite software package (Version 2.0.162). Through data mining, and later custom software manipulation, the reflectance spectrum was stored at 1nm intervals from 350-895nm. The reflection probe consisted of a custom made bundle of 6 UV grade illumination fibers surrounding the collection fiber. The unit was housed in a custom designed unit that illuminated the sample at 45° (see Figure 2).

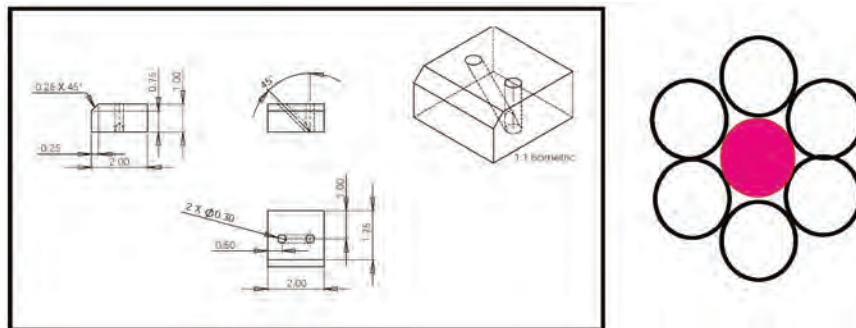

FIGURE 2. Schematic of the fiber optic holder and fiber optic cable.

The illumination spot size was an ellipse approximately 2.0mm by 1.5mm. The light source was a GE 21456 tungsten halogen lamp. The source and spectrometer were allowed to stabilize for about an hour before spectra were recorded. Barium sulfate (Aldrich, 99.9%) was formed into a pellet with a hand press and served as the 100% reflectance standard.

XRF spectra were recorded using a Philips Minipal4 Energy Dispersive X-ray Fluorescence Spectrometer (EDXRF). Experimental conditions were the same for all measurements, specifically, a Rh X-ray tube running at 13kV and 30µA with a thin film Al filter and integration time of either 60 or 120 seconds. The voltage was kept low to minimize any damage to the stamp. Spectra were stored on disk at a digitization interval 0.00916 Kev per channel over 2048 channels. Custom software, developed by the author, produced a matrix of scaled intensities for the elements Ca, Fe, Zn, Cr, Mn (Kα lines), Ba, (Lβ line) and Pb (Mα line) after background subtraction. The intensity of the Ar peak at 2.96 Kev was used as the scaling factor.

### THE CLASSIFICATION METHODS:

A total of five types of classification are considered here.

1. Best Match to the Munsell Color Chips through the reflectance spectrum.
2. Best Match to the Admiral Series Color Chips published by Morris<sup>4</sup> again through the reflectance spectrum. Both the above classifications yielded a “spectral match” and appeared to be a color match for all observers and lighting conditions.
3. CIELAB\* Uniform color space.
4. Romney Model: A three dimensional Euclidean representation of the Munsell color space (see below). The latter two methods give a firm mathematical estimate of the match between samples and a standard.
5. Analysis of the slope of the reflectance spectrum between 430-500nm and between 510-525nm. This may be considered a subset of method #2, but with only specific areas of the spectrum used in the analysis.

### BEST MATCH TO THE MUNSELL COLOR CHIPS OR ADMIRAL SERIES CHIPS:

An extensive database of observed reflectance spectra of all 1269 matte Munsell color chips is available online from the Spectral Color Research Group at the University of Eastern Finland<sup>5</sup> as a downloadable file. The 1269 reflectance spectra were digitized from 380 to 800nm in 1nm increments. A computer program in C# was written to compare the reflectance spectrum of the test stamp against each Munsell chip. An error function (Equation 1) was defined simply as:

$$\epsilon_j = \sqrt{\sum_{\lambda=430}^{660} (R_{\lambda} - R_{\lambda j}^*)^2}$$

EQUATION 1.

where  $R_2$  is the reflectance of the test stamp at wavelength  $\lambda$ ,  $R^*\lambda_j$ , and is the reflectance of the Munsell chip  $j$  at wavelength  $\lambda$ . The three chips that gave the lowest values of  $\epsilon_j$  were then reported by the program along with a graphical display of the fit.

The booklet produced by Richard Morris contains color chips of eight shades and hues for the two and three cent Admirals and are themselves original Munsell color chips. They include (using his naming scheme) carmine, dark carmine, deep red, rose red, orange red, pink, red and rose-carmine (Figure 3).

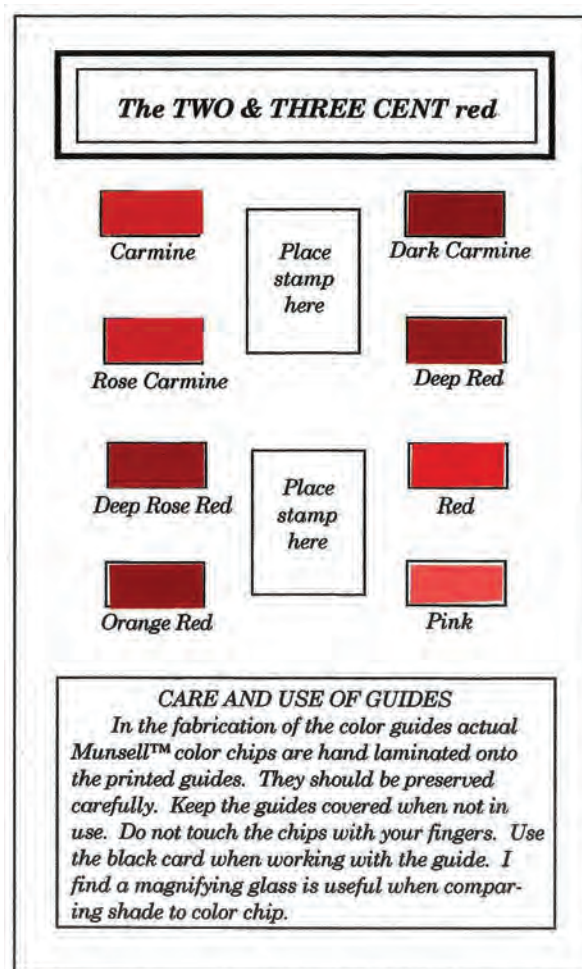

FIGURE 3. The Morris Color Chart for the red admirals.

He does not give the correlation of his nomenclature to the Munsell Color notation.<sup>6</sup> The reflectance spectrum of each Admiral chip was recorded by this laboratory, digitized and stored as noted above. The same algorithm as above was used to determine the best fit.

However, this approach did not give satisfactory results for both types of fits. The main objection to the full Munsell fit is that the classification is too fine. Not all stamps within the same block of stamps were determined to have the same shade (hue and chroma). The fit to the Morris Admiral chips suffered

from the same problem. Here the reflectance spectra of individual Admiral chips, for example the rose-carmine chip did not give a close match to certified stamps of that shade. This led to the same problem of multiple shade determinations for stamps within the same block. Part of the problem for both methods is that the Munsell Color chips in this study are a continuous matte, finish while the stamps are line engraved with raised ink. Both methods of classification will not be discussed further.

### CIELAB REDUCTION:

The methods and equations outlined in the text by Janos Schanda<sup>7</sup> were used to produce a C# computer program to give the Uniform Color Space constants  $L^*$ ,  $a^*$  and  $b^*$  for each sample.

The constants  $a^*$  and  $b^*$  correlate to the shade while  $L^*$  is associated with the lightness of the hue.

### THE ROMNEY MODEL

The procedure for the transformation of a reflectance spectrum to a Euclidean three dimensional representation of the Munsell Color System is outlined in the papers by Romney<sup>8</sup> and D'Andrade<sup>9</sup> and is briefly summarized here.

The authors have defined a Munsell conceptual (MC) coordinate space by three mutually perpendicular axes:  $m_1$  (Munsell value),  $m_2$  (5 blue-green versus 5 red) and  $m_3$  (10 purple-blue versus 10 yellow). Any color can then be specified by its coordinates in this space.

The  $m$ -values (Equation 2) are given by Romney<sup>8</sup> as:

$$\begin{bmatrix} m_1 \\ m_2 \\ m_3 \end{bmatrix} = \begin{bmatrix} -1.9401 \\ -0.4825 \\ 0.6990 \end{bmatrix} + \begin{bmatrix} -0.7304 & 0.0235 & 0.7031 \\ -0.0719 & 1.5681 & -1.4040 \\ 0.0583 & 0.9286 & 2.5996 \end{bmatrix} \begin{bmatrix} p_1 \\ p_2 \\ p_3 \end{bmatrix}$$

EQUATION 2.

where the  $p$ -vector (Equation 3) is obtained from a least squares fit to the following equation

$$S_{1 \times 301} = p_{1 \times 3} \times V_{3 \times 301}^T$$

EQUATION 3.

and where  $S_{1 \times 301}$  is the cube root of the reflectance spectrum of the test sample from 400-700nm at 1nm digitization intervals stored as a  $1 \times 301$  row vector, and  $V_{3 \times 301}$  is calculated from a singular value decomposition of the matrix formed from the cube root of the reflectance spectra of 1269 Munsell Color chips, also digitized at 1nm intervals from 400-700nm.

$$\sqrt[3]{R_{1268 \times 201}} = S_{1269 \times 301} = U_{1269 \times 3} D_{3 \times 3} V_{3 \times 301}^T$$

EQUATION 4.

As before, the web site of the Spectral Color Research Group<sup>5</sup> supplied the digitized spectra. Romney has determined the highly truncated  $3 \times 3$  UD matrix product (here called the  $p$ -vector above) is a satisfactory approximation and leads to the 3-dimensional Euclidean representation. MatLab<sup>10</sup> was used to calculate the orthonormal eigenvector matrix  $V_{3 \times 301}$  (Equation 4) through a singular value decomposition (SVD) of  $S$ . The  $V$  matrix is stored. It is then used repeatedly to perform the least squares reduction of equation (3) to give the  $p$ -vector for the current spectrum, again using MatLab. Further processing by MatLab using equation (2) gives the three values of  $[m]$ .

### THE SLOPE VALUES:

This classification scheme came late in the study. Over the course of recording the spectra of approximately 693 stamps, it became clear the reflectance spectra were partitioning themselves into two very broad categories. Stamps with a rose-carmine hue showed a definite negative slope between about 430-500nm (S430), while those stamps with a definite carmine hue showed a nearly zero or positive slope in this area. These divergent slopes are illustrated nicely in Figure 1. In addition, a very small percentage of the stamps showed a notable quadratic contribution to the curve between 510-525nm (S510), and formed the basis for the identification of the aniline ink pink shade. This important classification will be discussed in greater detail after the section on the XRF analysis.

Routines from MatLab were used to (1) average six readings per stamp, (2) determine the slope in the blue region, and (3) to evaluate the quadratic coefficient in the middle region (510-525nm).

## RESULTS AND DISCUSSION:

### THE ROMNEY AND CIE LAB\* DETERMINATIONS:

At the onset of this study, a single hairline stamp was chosen as a "quality control (QC) standard". The function of this stamp was to insure the spectrometer and the fiber optic system were functioning properly from day to day. The repeatability of the method was thus verified by holding the stamp identity and area of illumination constant, measuring the reflectance spectrum, and determining the Romney and CIE LAB\* parameters. Whenever a group of stamps was to be analyzed, a reading of this QC stamp was done at the start of an analysis. Additional readings of stamp testing were taken at roughly one hour intervals, and a final reading of the QC standard at the end of a session. Nearly 120 such readings were recorded for sample area 9 over a period of about two years (Figure 4).

An interesting prediction can be made from the standard deviation of the single area measurements. Firstly, the Romney



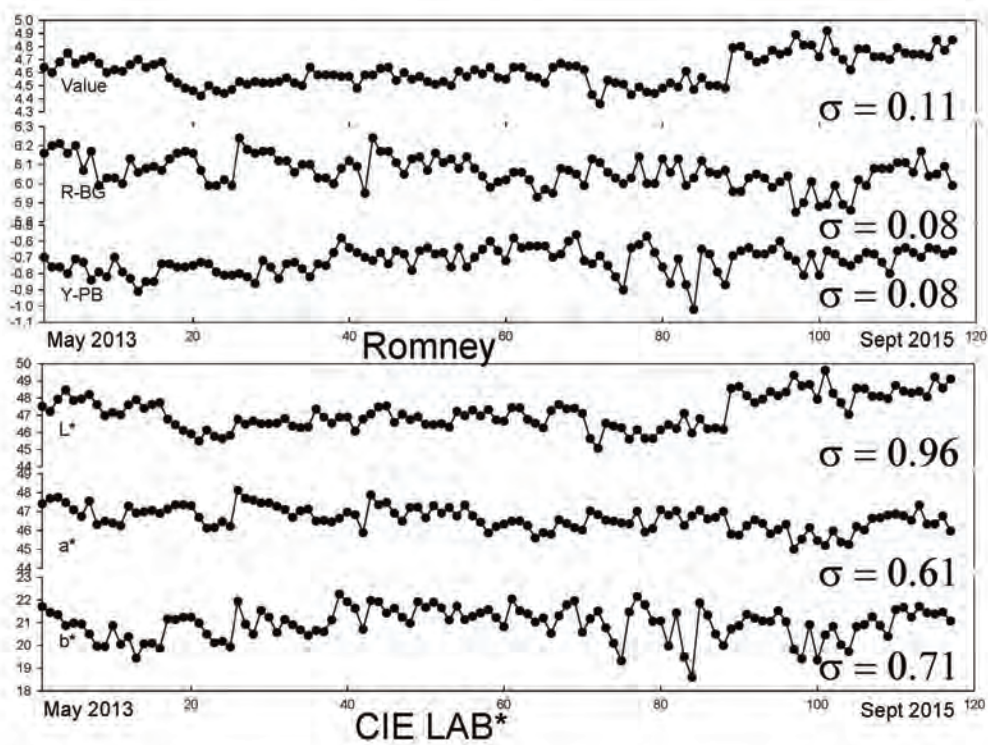

FIGURE 4. Single area reproducibility over a two-year period.

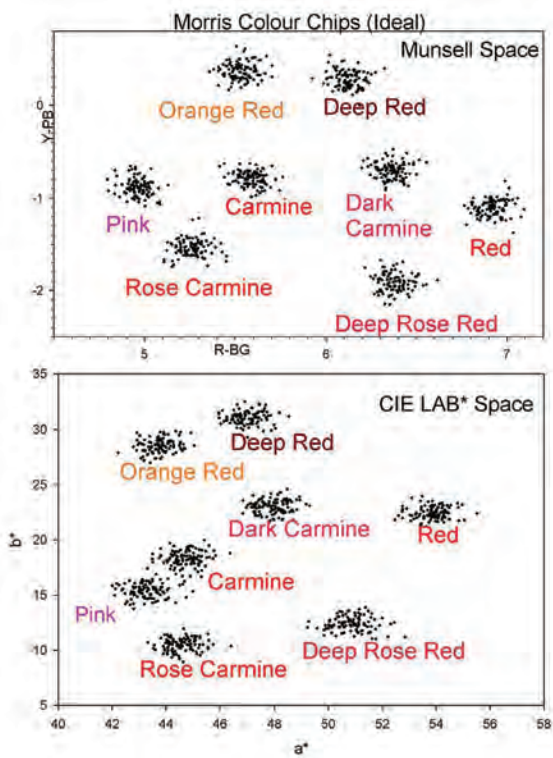

FIGURE 5. Idealized distribution (single area) based on the Morris Color Chips and a standard deviation from the quality control standard.

(R-BG /Y-PB) and CIE (a\*/b\*) parameters were measured for each of the eight Morris Admiral chips. Next, the two-year standard deviation of the two hue parameters was used to produce a 100 point Gaussian scatter plot for each of the eight Morris Admiral chips. The expected pattern for the eight shades produced well defined islands, suggesting both mathematical reduction methods may be able to segregate the shades. This pattern is illustrated in Figure 5.

Another important test was done since the spot size from the fiber optic cable is small, the variation of the determined parameters versus sampling area within a fixed stamp was determined for both models. The nine sampling areas are illustrated in Figure 6.



FIGURE 6. Sampling Areas.

Six reflectance spectra were recorded for each area. The determined parameters, along with the standard deviation based on the nine areas, is shown in Figure 7.

The substantial increase in standard deviation was likely due to the difference between the matte finish of the reference Admiral chips and the line engraved surface of the stamps. Areas 1-3 have a very fine dot pattern, with almost no white areas, and a general pooling of ink. The other areas are composed of comparatively widely spaced lines. In this area, the distribution of ink is more uniform and the placement of the reflectance probe less critical. Area 9 was found to give the most consistent results and was used as the exclusive test area.

The variation of shade (parameters R-BG and Y-PB or a\* and b\*) with ink density (V or L\*) was a limitation of the above models since ink density should not affect shade determination. This defect has been illustrated by Romney in his figure 6<sup>8</sup>. The variability of the shade parameters with ink density limited the ability of this method to segregate the eight shades by their reflectance spectrum. This is illustrated in Figure 8 where the new overall standard deviation has been applied to the eight Morris shades.

Given the limitations in the model, the next section summarizes the findings.

Munsell Conceptual (Romney)						
Area	Rose Carmine			Carmine		
	V	R	B	V	R	B
1	5.37	4.95	-0.31	5.37	5.13	-0.34
2	5.13	5.16	-0.47	5.30	5.56	-0.45
3	5.08	4.74	-0.27	5.08	5.19	-0.34
4	5.68	4.74	-0.09	5.52	5.11	-0.26
5	5.21	5.27	-0.36	4.67	6.38	-0.64
6	5.44	5.24	-0.35	4.69	5.85	-0.47
7	5.02	5.68	-0.44	4.79	6.00	-0.51
8	5.79	5.10	-0.32	4.76	6.05	-0.58
9	5.54	5.29	-0.32	4.92	5.95	-0.54
<b>Avg</b>	<b>5.36</b>	<b>5.13</b>	<b>-0.33</b>	<b>5.01</b>	<b>5.69</b>	<b>-0.46</b>
<b>Std</b>	<b>0.27</b>	<b>0.30</b>	<b>0.11</b>	<b>0.32</b>	<b>0.46</b>	<b>0.13</b>
<b>Std (Area 9)</b>	<b>0.08</b>	<b>0.08</b>				

CIE LAB*						
Area	Rose Carmine			Carmine		
	L	a	b	L	a	b
1	52.48	36.61	18.61	51.34	32.86	18.30
2	50.48	38.64	18.17	50.99	36.71	19.31
3	49.74	34.76	17.89	48.71	33.21	18.31
4	55.20	34.82	19.61	52.78	32.71	19.01
5	51.41	39.39	19.69	46.10	43.76	21.63
6	53.77	40.02	19.90	46.15	40.88	20.80
7	50.39	43.28	21.20	47.17	42.10	21.22
8	56.88	39.29	19.64	47.02	42.78	21.01
9	54.75	40.42	20.40	48.33	42.01	20.88
<b>Avg</b>	<b>52.79</b>	<b>38.58</b>	<b>19.46</b>	<b>48.73</b>	<b>38.56</b>	<b>20.05</b>
<b>Std</b>	<b>2.49</b>	<b>2.77</b>	<b>1.06</b>	<b>2.43</b>	<b>4.66</b>	<b>1.31</b>
<b>Std(Area 9)</b>	<b>0.61</b>	<b>0.71</b>				

FIGURE 7. Summary of the variation of the shade parameters determined from the nine selected stamp areas.

### THE DETERMINATION OF THE CIE AND MUNSELL PARAMETERS FOR THE 2¢ CARMINE ISSUE:

The reflectance spectra of approximately 693 stamps, including 83 showing hairlines, were recorded and consisted of individual stamps, blocks of two or four stamps and plate blocks of various sizes (2-10 stamps). The graph shown in Figure 9 depicts the variation of the MC (R-BG, Y-PB) and LAB (a\*, b\*) parameter values for all stamps (approximately 693) in this study.

The contribution from the hairline stamps of Plate 4 is shown in red. Since the hairlines from this plate are considered by most philatelists to be the rose-carmine shade, there has been no grouping of this shade by either Munsell or CIE parameters. In fact a continuum of values is obtained. As outlined above, it appears the Value (or L\*) had a significant effect on the two other parameters and significantly broadened what may have been a segregation of shades into island ellipses. Such a segregation is seen by Harendeen et.al.<sup>1,2</sup> in their figure 12. More likely, however, is the shades for this issue do form a continuum of hues irrespective of the ink density. This is not unexpected given the issue's long printing history, the difficulty of maintaining consistent ink chemistry during the early 20<sup>th</sup> century, and the disruptions caused by World War I. It thus became necessary to find another set of parameters that could be used to set limits on each shade. Such a scheme is described next.

The 'hairline' stamps share a common feature in their reflectance spectra: A prominent negative slope in the region from 430-500nm, as seen in Figure 1. For the 82 'hairline' stamps studied, the slope value ranged from -0.0668 to -0.0329. A further justification comes from a certified rose-carmine (106c) stamp with a value of -0.0619nm<sup>-1</sup>. If the maximum slope (-0.0300) from all the hairline stamps is taken to be the start of

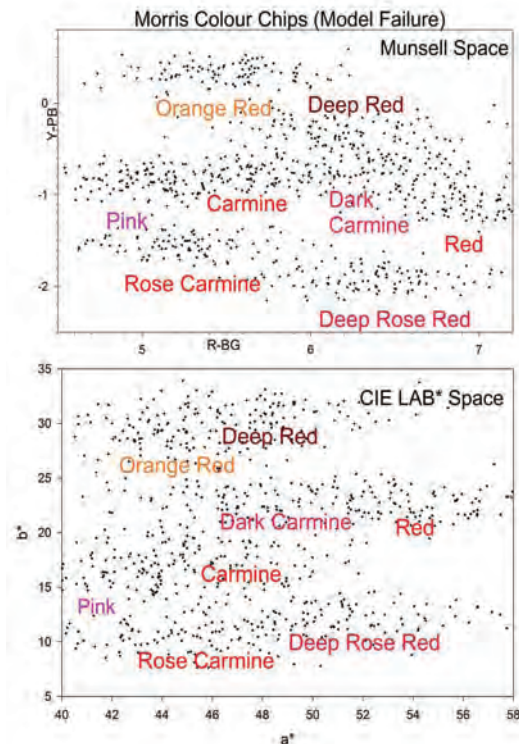

FIGURE 8. Idealized distribution expected with the full standard deviation due to model failure.



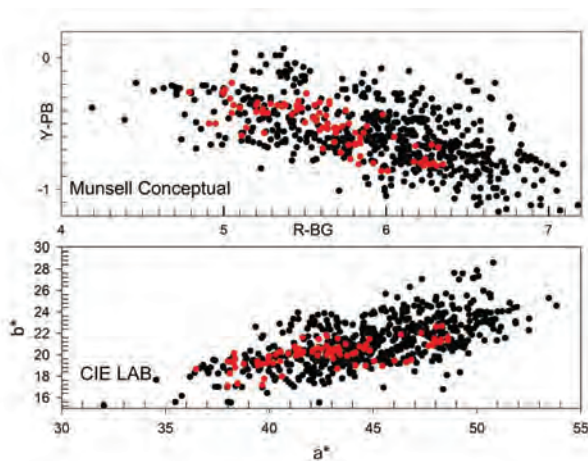

FIGURE 9. The near continuum of shades shown for the 2c carmine issue. The red dots are the contribution from the ‘hair-line’ issue and are generally accepted as rose-carmine.

the rose-carmine shade, then Figure 10 shows the distribution over the approximately 483 stamps studied.

Stamps from blocks were only counted once in this histogram and thus the total is smaller than the total number of approximately 693 stamps actually measured. The histogram shows a nice grouping of the two major shades for this issue, and the method gives the best, unbiased, estimate of dividing the shades into rose-carmine and carmine. In this figure, the contribution by rose-carmine hairline stamps (Plate 4) is shown in red.

### XRF ANALYSIS:

Figure 11A shows the XRF spectrum of the middle stamp of a 5-member hairline on Plate 4. Strong lines appeared for the elements Ca, Ba and Zn.

A moderate intensity contribution from Pb was indicated by the weak  $M\alpha$  line at 2.3Kev although the elemental concentration by Pb is significant based on its  $L\alpha$  line (not shown). Fe was present in both the stamp face and the salvage in roughly the same intensity and suggested the Fe contribution was from the paper. In this spectrum, Mn may also be present especially from stamps in later printings that show a definite but moderate concentration of Mn. Figure 11B has a similar plot showing the elements present in a dark carmine stamp. Here, Zn is nearly absent, Ba is low and there is a contribution from Cr. The elements Ca, Fe and Pb are present as before. In an attempt at a semi-quantitative analysis, the line intensities for the elements Ar, Pb, Ca, Ba, Cr, Fe and Zn were background subtracted and scaled by a factor that gave a constant value for the weak but persistent Ar peak at 2.96 Kev. Considerable time was spent trying to find a correlation to the relative and absolute levels of each element to the shade of a stamp. No discernable pattern was observed *except* for the Zn level. Here there is a definite correlation between the slope of the reflectance curve between 430 and 500nm and the Zn level. Slopes associated with the rose-carmine shade (slopes between -0.100

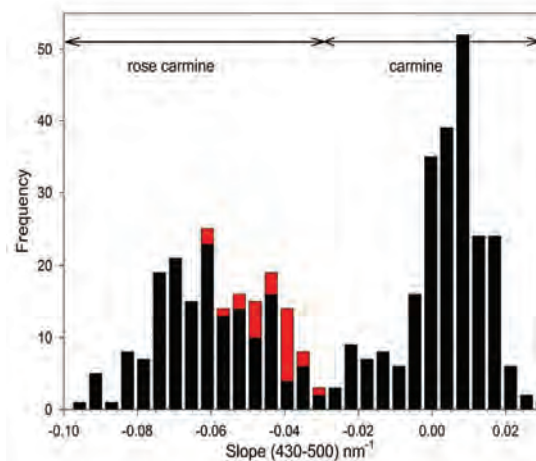

FIGURE 10. Histogram showing the distribution of stamps based on the slope in the 430-500nm region. The contribution by the rose-carmine hairline stamps is shown in red.

and -0.0310) have high levels of Zn, typically greater than 3000. The carmine (-.0310 < slopes < 0.00100) typically have Zn levels significantly below 2000. The pink shade (discussed in its own section below) and a few apparent rose-carmine stamps are anomalous, in that the levels of Zn are very low but, as will be shown, form a distinct grouping by themselves.

The low levels of zinc in the carmine and pink shades may have been a result of a shortage of Zn compounds during the First World War. According to Coulson<sup>11</sup>, zinc became an economically important metal in the early part of the 20th century, for, he states: “... lead and zinc, the latter metal having boosted from annoying by-product to key strategic metal by the First World War”.

Figure 12 shows the correlation of Zn content, slope and over time, where the approved date for 50 plate blocks has been used to fix the minimum date of stamp production. A slow transition to the positive linear coefficients (carmine) from the large negative coefficients (rose-carmine) occurred from Plates 65-98. Simultaneously, the Zn content decreased to near zero. This transition time likely gave rise to multiple shades due to a changing ink chemistry. This is the period of the ‘aniline ink’ variety. A companion paper to this study will go into greater detail about this interesting variety and will use Fourier Transform Infrared (FTIR) spectroscopy to explore the ink chemistry. But for now, only a brief discussion of the ‘aniline ink’ variety and the pink shade follows.

### THE ANILINE INK VARIETY AND THE PINK SHADE:

The pink shade of the 2c carmine Admiral series has a catalog value some 50 times greater than the other shades<sup>12</sup>. Thus, it is not surprising there is considerable interest in this shade. Because of the premium associated with this shade, the expertizing agencies are often asked to certify the shade. In Figure 13, the reflectance spectrum of a certified pink shade stamp

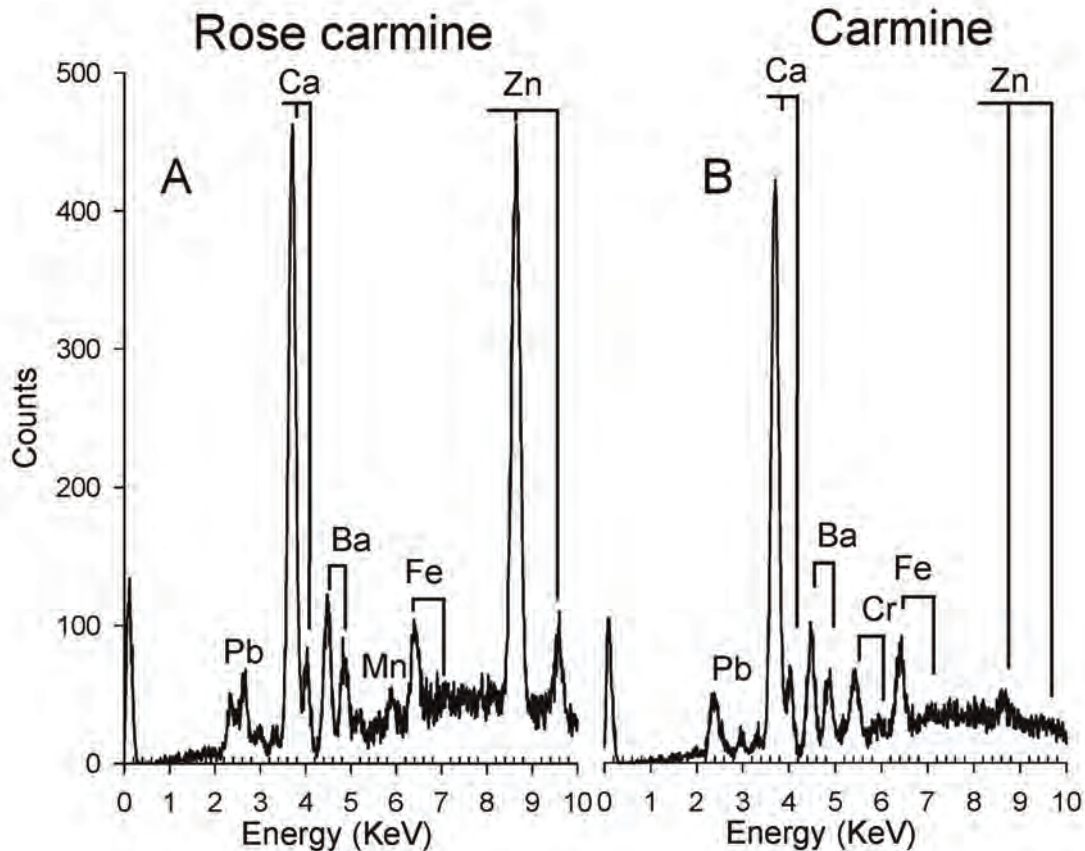

FIGURE 11. XRF spectrum of a rose carmine stamp (A) and a carmine stamp (B). Note the near absence of Zn in spectrum (B) and the appearance of a Cr peak.

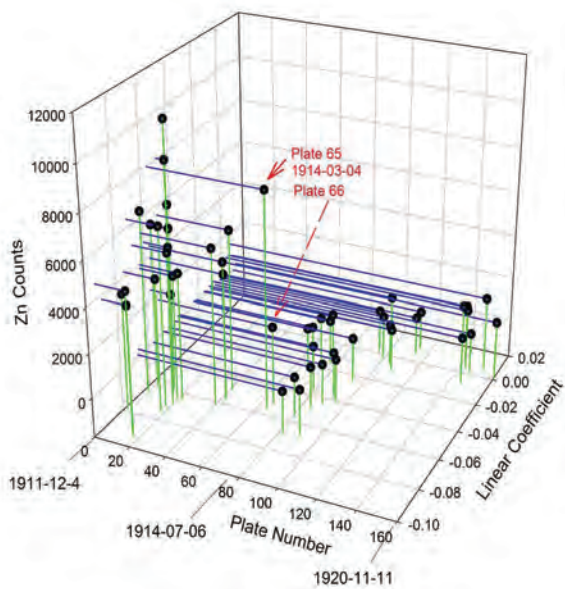

FIGURE 12. A 3-D plot of Plate Number (Year) vs Zn content vs slope at ~430nm. Note the sharp transition to low zinc values around Plate 66 which was approved for use in March of 1914.

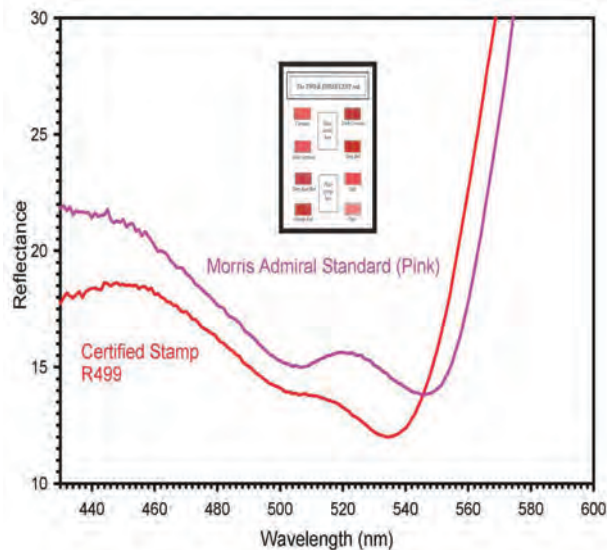

FIGURE 13. Reflectance spectra in the range 430-600nm showing the characteristic quadratic term in the Morris Admiral Standard and that of a certified pink stamp.

was compared with the Morris pink shade Munsell color chip. The area around 500nm shows a marked ‘hump’ in both spectra. The stamp labeled ‘R499’ is a single stamp, but Plate block 82 also shows this prominent feature has been certified as *Rose Carmine*, Aniline Ink Variety. The area around 500nm was fitted to a quadratic equation to determine the quadratic coefficient. Negative values of the coefficient are associated with this protuberance in the spectrum. A graphical 3D time line of Zn content, quadratic coefficient and plate number (time) is presented in Figure 14.

An interesting question arises from the correlation of zero Zn content with the pink shade. Is the stamp pink because it is a rose-carmine stamp with very low Zn content? Certainly this is possible since the linear slope of the pink shade in the region from 420 to 500nm is similar to that of the rose-carmine stamps. The other possibility is the pink stamps started with a dye that was very different than the ‘normal’ dyes used in the production of the rose-carmine stamps. Since Zn was now in short supply because of the war, the dilution of the ink’s strong color was performed by compounds of Ca, Ba and Pb alone. There is evidence to support the use of this new dye. The stamps with the high negative quadratic coefficient showed considerable ‘bleed-through’ as illustrated in Figure 15.

Philatelists associated the bleed-through with the use of an inferior lake, and the ink produced from it was to be called ‘aniline ink’. In a future paper the author will look more deeply into the problem and at this writing, the ‘aniline ink’ variety was likely caused by production problems in the ink manufacturing during the war years. Regardless of the cause, there was a unique shade that could be identified spectroscopically with three characteristics taken from the two expertised certificates stating a pink shade: a quadratic coefficient less than or equal to -0.0020, a low or near zero Zn content and a linear coefficient smaller than -0.03. Only seven stamps of the approximately 693 stamps measured fit this tight criterion. Certainly, this small number justifies the price premium. If the quadratic criterion is relaxed to stamps with coefficients smaller than -0.0015, the total number jumps to 15, still a small percentage of the total. All 15 stamps showed some or prominent bleed through.

**CONCLUSIONS:**

This study of the 2¢ carmine Admiral Issue of Canada has used reflectance and XRF spectroscopies to categorize the various shades. Direct comparison of reflectance spectra to standard Munsell reflectance spectra, or to the Morris Admiral chips, yielded inconsistent predictions for stamps within the same block and generally gave poor matches to the reference spectra.

An analysis protocol was developed that used the CIE LAB formalism and a mathematical reduction developed by Romney. The latter is based on the Munsell color system. In both mathematical procedures, an experimental reflectance spectrum was reduced to a set of three parameters. The mathematical treatments show that within a data set of approximately 693 unused stamps, both methods predicted a near continuum of shades with no obvious blocking into discrete shades. Both methods suffered from model defects in that ink density does affect shade determination.

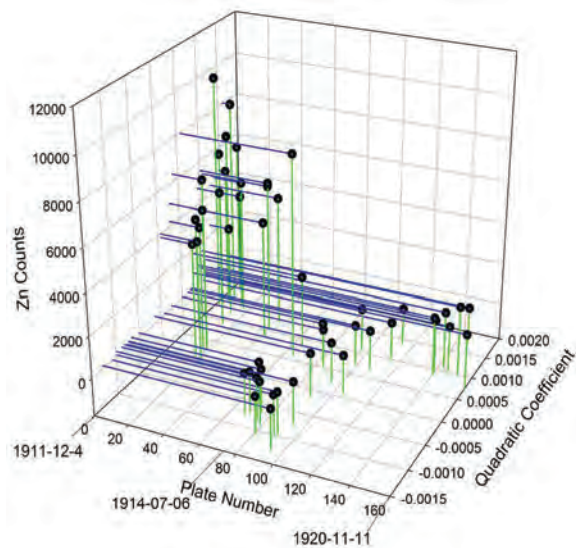

FIGURE 14. 3D plot showing the high negative coefficient bunched around plates 70-90.

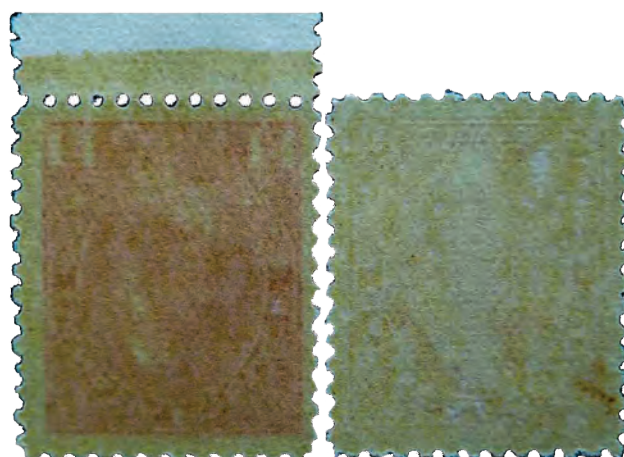

FIGURE 15. 3D plot showing the high negative coefficient bunched around plates 70-90.

During the recording of the spectra of many stamps, it became clear stamps with visually similar shades were blocking into two major groups based on the slopes in the 430-500nm region. If it was assumed the Plate 4 hairline stamps were all rose-carmine, then stamps with slopes <-0.0300 were assigned as rose-carmine. Slopes greater than this were broadly classified as carmine. This partitioning into two broad shades was supported by the slopes seen in the reflectance spectra of the Morris Admiral Series Reference Color chips for these two shades. This classification scheme resulted in a noticeable blocking into two major shades, rose-carmine and carmine, as suggested by the Scott catalogue.



Philatelists have long observed a relatively scarce and distinct shade in this issue, that being the pink shade, Scott 106b. There is experimental evidence, presented here, for this shade. Approximately 2% of the stamps studied had a negative quadratic coefficient in the narrow region from 510 to 525nm, that is to say a visible hump in the spectrum in this region. Inspection of the reflectance spectrum of the pink Morris Admiral Series Munsell chip standard gave a negative quadratic coefficient of -0.0045. Two certified pink shades stamps evaluated by four different expertizing agencies averaged to -0.0031. The pink shade was identified through a stringent set of criterion based on the range for the quadratic coefficient, the range of the linear coefficient and the Zn content of the stamp.

XRF spectrometry was used in an attempt to correlate the elemental composition and its variation with changes in the Munsell Conceptual parameters or the CIE parameters of individual stamps. No obvious correlation existed. This suggests the printing process in the early 20<sup>th</sup> century was more of an art than a science. The carmine lakes used as pigments likely showed large batch-to-batch variations. The final hue and shades of the ink were modified on the printing floor through the addition of dilutants. Based on the linear and quadratic coefficients mentioned above, high levels of Zn were strongly associated with the rose carmine shade. Stamps with negligible or small Zn levels were associated with the carmine shade. Finally, in a class by itself, the pink shades with negative quadratic coefficients had near zero zinc levels, but with linear slopes in the 430-500nm region that placed them within the rose-carmine block rather than carmine.

I realize many philatelists will say that a particular stamp is pink based on their visual comparison to standards in their collection. They are not wrong. What is presented here is a way to clearly and unbiasedly sort, from the many visual shades of this issue, a selection of stamps with similar characteristics. Within the limitations of this study, only two major groupings are possible. A third grouping which emerged, consisted of only a limited number of stamps and was based on the three criterion listed above. It was called the 'aniline ink pink shade' because of these characteristics and their 'pink' hue.

## ACKNOWLEDGMENTS:

The author wishes to acknowledge the valuable work of Vince Shaff in the design and construction of the reflectance cell used in this study and for the procurement of the spectrometer. Thanks are also due to John Barwis and Harry Brittain along with Jim Allen and Vince Shaff for a critical reading of an earlier version and for many fruitful discussions during this study. To Thomas Lera of the National Postal Museum for his patience and help in obtaining the XRF data on the plate blocks, his help is most appreciated. And, to Fred Baumann of the American Philatelic Research Library (APRL), who supplied very valuable and complete references to the available literature on the aniline ink problem. Finally, I am grateful to the Institute of Analytical Philately (IAP) for a generous grant to obtain the spectra and present this work.

The author may be contacted at [CH2Se@sbcglobal.net](mailto:CH2Se@sbcglobal.net).

## NOTES

1. Harris, Robin D., editor, "2013 Unitrade Specialized Catalog of Canadian Stamps", The Unitrade Press, Toronto, Canada, 2013.
2. Harendeen, D.L., Allen, J.A., and Lera, T. "Philatelic Shade Discrimination Based on Measured Color". Report IAP-2010-1. Institute for Analytical Philately, Inc., Nov 2010.
3. [http://en.wikipedia.org/wiki/Munsell\\_color\\_system](http://en.wikipedia.org/wiki/Munsell_color_system). accessed November 28, 2015.
4. Morris, Richard M, "Color Guides for the Admiral Issue of Canada", Pittsboro Philatelics, Norfolk MA, 2000.
5. <http://www.uef.fi/fi/spectral/munsell-colors-matt-spectrofotometer-measured>. accessed November 28, 2015.
6. Richard Morris indicated in a private communication dated January 16, 2014, that he is unable to disclose the chips used due to proprietary constraints of the new owners of his copyright.
7. Schanda, Janos, "Colorimetry: Understanding the CIE System", Wiley-Interscience, Hoboken, NJ, 2007.
8. Romney, A. Kimball, "Relating reflectance spectra space to Munsell color appearance space", J. Opt. Soc. Am A, 25(3), 658-666 (2008)
9. D'Andrade, R.G. and Romney, A.K., "A quantitative model for transforming reflectance spectra into the Munsell color space using cone sensitivity functions and opponent process weights", Proc. Natl. Acad. Sci. U.S.A. 100, 6281-6286, 2003.
10. MathWorks: <http://www.mathworks.com/products/matlab>. accessed November 28, 2015.
11. Coulson, Michael, "The History of Mining: The events, technology and people involved in the industry that forged the modern world." Harrison House Limited, 2012, p. 197
12. Harris, op. cit p 76

# Towards a Stamp-Oriented Color Guide: Objectifying Classification by Color

*John M. Cibulskis, Ph.D.*

---

**ABSTRACT.** The Michel Color Guide Version 38 is the current standard for the identification of colors of German stamps. Although Michel is to be congratulated for its effort to standardize color identification, the abstract process used for creation of the guide leaves something to be desired. The issue is that for some stamps, there are just no truly close or matching colors in the guide. If one is taking a subjective approach to color matching this is not much of a problem, and the question “Do these look like the same color?” can be answered. However, in the process of trying to find an objective way of comparing two colors, the lack of “close” colors make the task difficult, if not impossible.

An alternative approach to the creation of a color guide (either in hard copy or computerized) would be to include colors that “correctly” match the actual colors of the stamps. Several small color guides have already attempted to carefully describe the color variations of a few stamps. However, these are still subjective in that the color matches are to be performed “by eye” and that the texture of the color swatches differ substantially from the texture of the stamps themselves. For example, see, *Scott Specialized Color Guides for United States Stamps*.<sup>1</sup>

In addition, there may be several colors corresponding to each color variety listed in the stamp catalog. (For example, see *Germany 1872-1900 A Philatelic & Postal History Handbook of Germany and her Colonies* by Hinton-Blaker for a listing of the sub varieties of the major varieties of Michel 37, hereafter abbreviated Mi 37, where he lists 19 sub-varieties of the 6 major varieties.<sup>2</sup>)

The whole process would start with scans of stamps of known variety. From a group of such scans, we would extract one or more colors representative of the sub varieties. We might even add more sub varieties than are currently acknowledged. Presented with a new stamp, we could then apply objective criteria using the guide to match the stamp’s color.

The purpose of this paper is to indicate a process which could be followed to create such a stamp-oriented color guide. We would restrict ourselves to computer processes for analyzing the stamp colors, grouping stamps into clusters of “close” colors, extracting a representative color for each group to be put into the color guide, and matching the stamp color to those in the guide.

## **IMAGE PREPARATION**

Each stamp image used in this analysis was created by a scan on a Canon LiDE 120 at 300 DPI with a black background. All image enhancement was turned off. The images were saved as jpg files with minimal compression. For each analysis, the image files were named consistently by a prefix followed by an integer from 1 to the number of images in the study. (For example, “Mi 45 1” through “Mi 45 223”). The purpose for this naming convention is to allow for automatic consecutive processing of all the stamps in the study

and to easily discuss the various images. The terms “stamp” and “image” are used interchangeably in this paper, since all analyses of the stamps will be made through their images. A more complete discussion of the image preparation may be found in “Analysis of Color Varieties Using Scanned Images.”<sup>3</sup>

## COLOR REPRESENTATIONS

RGB is Red, Green, Blue representing a color with three integers in the range of 0 thru 255, giving rise to  $256 \times 256 \times 256 = 16,777,216$  different colors. All of our colors begin with this representation since this is the way in which the scanners save the colors to the files. These are certainly enough different colors for any study of stamp color varieties. Since this is such a common representation for color, we shall later mention several distances that we may apply using the RGB values.

HSL is the Hue, Saturation, Luminance representation. For our purposes, we will measure each of these (real) parameters on the interval from 0 to 1. The hue can be thought of as a value on a circle of circumference 1. At 0 we have the color red and as we go around the circle we again encounter red when we reach 1. This is rather inconvenient for picturing stamps whose color is almost red. Consequently, we shall often use a folded-hue (or, hue-folded, HF) scale which instead goes from -0.5 to 0.5 (with 0 = red in the middle) when looking at stamps whose hues are close to 0 or 1.

Saturation is a measure of the intensity of the color. At values close to zero the color will be grayish and at 1 it will be totally saturated. Note that “grayish” can also be easily described in terms of RGB as the three R, G, B values being close to each other.

Finally, Luminance is a measure of light intensity, from 0 (dark) to 1 very bright. You might think that the “brightest”

colors would then correspond to  $L=1$ . This is deceptive since  $L=1$  gives us white. The “brightest” actually occur at  $L=0.5$ . Moving towards 0 gives us darker and darker colors until we arrive at black. Moving towards 1 gives us lighter and lighter colors ending with white.

The Lab color model was defined by the CIE (*Commission International de l'Eclairage*) in order to have a color model which was independent of the instrument used for the color determination. “L” is the luminance. “a” varies from green (negative values) to red (positive values). “b” varies from purple (negative values) to yellow (positive values). The colors are described by a combination of these three values. This color model will be used only when discussing a “distance” measure between colors.

## ISOLATING THE DESIGN PIXELS FOR ANALYSIS

This procedure is illustrated through a study of the single image “Mi 37 Canon 6” (this is the 6th stamp in the collection of 32 images of Mi 37 sampled).

The outer vertical lines represent cutoff values which indicate the pixels used for the analysis of the stamp. The center vertical line is at the average luminance of those included pixels. (Figure 1)

This histogram shows a typical situation. The left-peak represents the pixels in the surrounding dark region and in the cancellation. The right-peak is the paper. The center-peak is the design. To begin, the design for study must be isolated by moving the cutoffs so that only the center peak is included. (Figure 2) For the purpose of this paper it is intentional to avoid the effects of the paper on ANY color measurement.

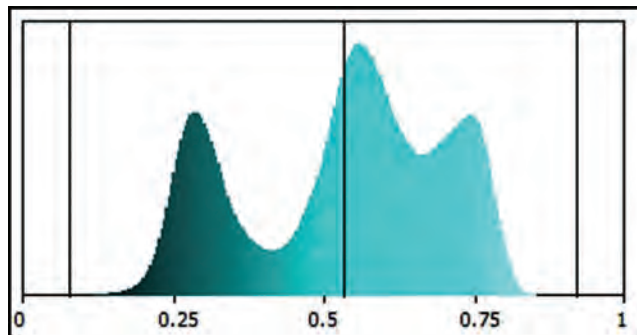

FIGURE 1. Mi 37 Canon 6 and its Luminance Histogram.



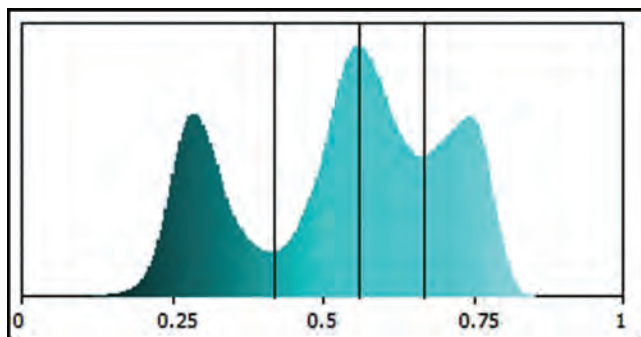

FIGURE 2. Cutoffs Adjusted to Include Only the Design.

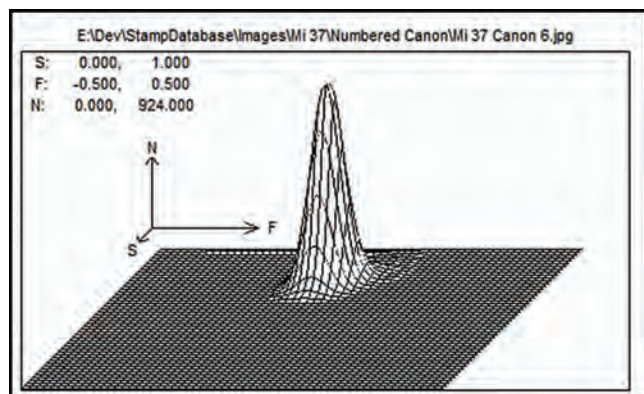
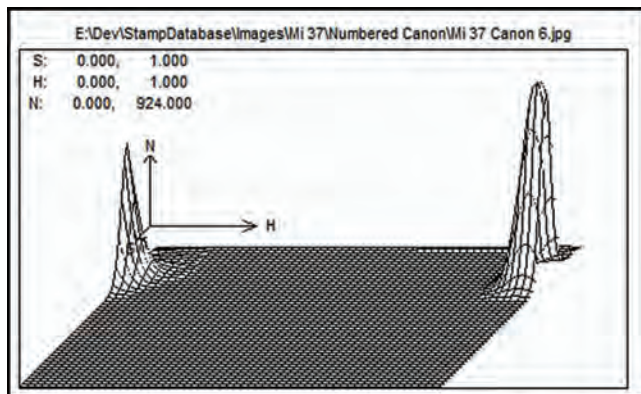

FIGURE 3. Hue-Saturation Histogram and Hue-Saturation Histogram with Hue Folded.

The result is seen above. Notice some gray pixels are included. They need to be removed as they will affect the computed Luminance. We will return to this shortly.

There are several other plots that will be useful to us later. These are the Hue Histogram and the Saturation Histogram. The most useful histogram is the Combination Hue-Saturation Histogram. (Figure 3)

In looking at the HS histogram, one can see pixels with low saturation (gray pixels) are still included. These correspond to the short bumps behind the main peak. We can eliminate them by excluding gray pixels. At this time, we have chosen to do this by removing all pixels with RGB values within 45 of each other. The result is shown in Figure 4.

Notice there are no longer any gray pixels in the Included Pixels image and that the base of the HS histogram peak is now clearly defined. The stamp is now ready for analysis.

### EXTRACTION OF THE DESIGN COLOR

Once these preliminaries are computed, the process is straightforward: (1) determine the HS coordinates of the peak in the HS Histogram; (2) use the average Luminance to give the final HSL description of the color. (Table 1)

TABLE 1. Color of Mi 37 Canon 6.

H	0.9750	R	170
S	0.2500	G	114
L	0.5593	B	122

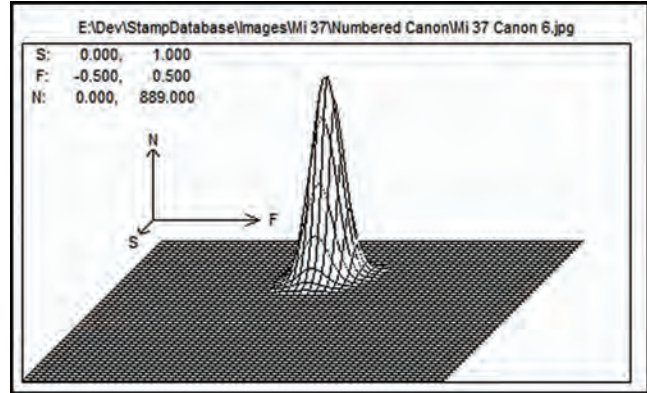

FIGURE 4. The Included Pixels and the HS Histogram after Gray Exclusion.

### COMPARISON OF STAMP COLORS

The term “distance function” used in the following does not necessarily imply it is a metric; some of the properties of a metric may not be satisfied (and we don’t care). What we really mean is that it is a function on pairs which assigns 0 to the pair (x, x) and larger positive numbers to indicate inequality.

A “similarity function”, refers to a function on pairs which has the value 1 on the pair (x, x) and smaller values (perhaps even negative) to indicate dissimilarity.

Every distance function gives rise to a similarity function in the following way: (1) normalize the distance function so its maximum value is 1; (2) define the similarity function to be  $\text{similarity}(x, y) = 1 - \text{distance}(x, y)$ .

A similarity gives rise to a distance by the formula  $\text{distance}(x, y) = 1 - \text{similarity}(x, y)$ .

The five distance functions we have used in this study are:

- A. The Euclidean or  $L_2$  Distance based on the RGB representation. That is, the distance =  $\sqrt{(R_1 - R_2)^2 + (G_1 - G_2)^2 + (B_1 - B_2)^2}$
- B. The Taxi or  $L_1$  Distance defined by  $\text{Distance} = |R_1 - R_2| + |G_1 - G_2| + |B_1 - B_2|$
- C. The Max or  $L_\infty$  Distance defined by  $\text{Distance} = \max\{|R_1 - R_2|, |G_1 - G_2|, |B_1 - B_2|\}$
- D. A distance utilizing the HSL representation defined by  $\text{Distance} = C_H \times \text{Dist}(H_1, H_2) + C_S \times |S_1 - S_2| + C_L \times |L_1 - L_2|$ , where the coefficients  $C_H, C_S, C_L$  (scanner dependent) are chosen to correctly identify the colors in the color guide. The  $\text{Dist}(H_1, H_2)$  is computed on the circle of

circumference 1 so that  $C_H$  may be as much as twice the size of the other coefficients.

- E. The DeltaE distance defined and studied by the CIE. We shall use the original version defined in 1976 and refer to it as DeltaE76.<sup>4</sup> It is merely the Euclidean distance between the two colors in the Lab color space. That is:  $\text{Distance} = \sqrt{(L_1 - L_2)^2 + (a_1 - a_2)^2 + (b_1 - b_2)^2}$

The above presuppose the perceived color of a stamp can be described by a single color. In actuality, the stamp design almost always contains pixels with colors varying over a fairly wide range. This can be seen by selecting two single pixels from the design and comparing their colors. They will almost assuredly be different. The actual perceived color of the stamp image depends upon all the pixels in the design; they all contribute to the overall color effect. Thus, it makes sense to consider the entire HS Histogram as the “color” of the stamp and the average Luminance as the brightness of the color. This leads to the following similarity definitions.

Letting  $H_1$  and  $H_2$  denote the two HS-Histograms and  $d(H_1, H_2)$  be R, the formula for the Pearson R Correlation Coefficient is given by:

$$d(H_1, H_2) = \frac{\sum_I (H_1(I) - \bar{H}_1)(H_2(I) - \bar{H}_2)}{\sqrt{\sum_I (H_1(I) - \bar{H}_1)^2 \sum_I (H_2(I) - \bar{H}_2)^2}}$$

where

$$\bar{H}_k = \frac{1}{N} \sum_J H_k(J)$$

and  $N$  is the total number of histogram bins.<sup>5</sup>



R varies between -1 and 1 with 1 indicating a total positive correlation between the histograms, 0 indicating no correlation and -1 indicating a total negative correlation between them. Experimentation with HS-Histograms for stamps has shown we should expect a correlation of 0.9 or higher when stamps have the same color shade. This cutoff seems to vary dependent upon the major stamp catalog numbers. Perhaps color varieties have not been cataloged as consistently as might be desired.

ASUM, absolute sum of scaled differences also known as data-adaptive summation, is another measure of the similarity (or difference) between two histograms that is perhaps easier to understand than R.<sup>6</sup>

This process is begun “normalizing” the two histograms so the sum of the bins (now treated as real numbers rather than integers) totals to 1. The resulting 2-dimensional array (no longer a histogram) may be considered to describe the “shape” of the HS histogram. We want to compare these two shapes. For each cell, we compute the absolute value of the difference between the values in the two histograms and sum up all these values. The result is a measure of the “distance” between the two HS histograms, which varies between 0 and 2, with 2 being the maximum distance attainable. This occurs when the two peaks are in different parts of the HS histograms with no overlap. This can be changed into a similarity measure by multiplying it by 0.5 and subtracting it from 1. The result would be a number between 0 and 1 with 0 indicating no similarity, and 1 indicating complete similarity. For our purpose, it turns out to be more useful for us to multiply it by 0.25 instead of 0.5. The result is a number between 0.5 and 1, with 0.5 indicating no similarity.

Both of these measures rely only on H and S and take on the value 1 when the two scaled histograms are identical. To take into account the luminance differences, the measures RL and ASUML have been added which include the luminance

differences in their calculations. All of these are similarity measurements in that as the value approaches 1 they are considered to be more similar.

To add Luminance to R or ASUM, let LSIM denote (1 - L Difference). Since the difference between the luminances (L Difference) is a number between 0 and 1, LSIM is a number between 0 and 1, with values close to 1 indicating that the luminances are nearly equal.

It is convenient to think of these similarity measures as probabilities. Think of R as the probability that the two stamps have the same H and S values assuming that they have the same L, and LSIM as the probability that the L values are equal. (We are NOT asserting these are the actual probabilities. They share some of the properties of a probability and thinking of them as probabilities helps us to understand the following definitions.)

From the conditional probability equation:  
 $P(A \text{ and } B) = P(A|B) \times P(B)$ , we define:  
 RL = the probability the H, S, and L values for the stamps are equal  
 =  $P(A \text{ and } B)$ , where A = “H and S are equal”  
 and B = “Ls are equal”  
 =  $P(A|B) \times P(B)$   
 =  $R \times LSIM$

This forms the justification for our definition and use of RL.

Similarly, we define:  $ASUML = ASUM \times LSIM$

As an example of these similarities, the comparison of two copies of Mi 37 is shown. For both images, gray pixels at level 30 have been excluded. All pixels with R, G, and B values, all within 30 from each other, have been excluded. (Figures 5-7)



FIGURE 5. Mi 37 Canon 2 and Mi 37 Canon 3.

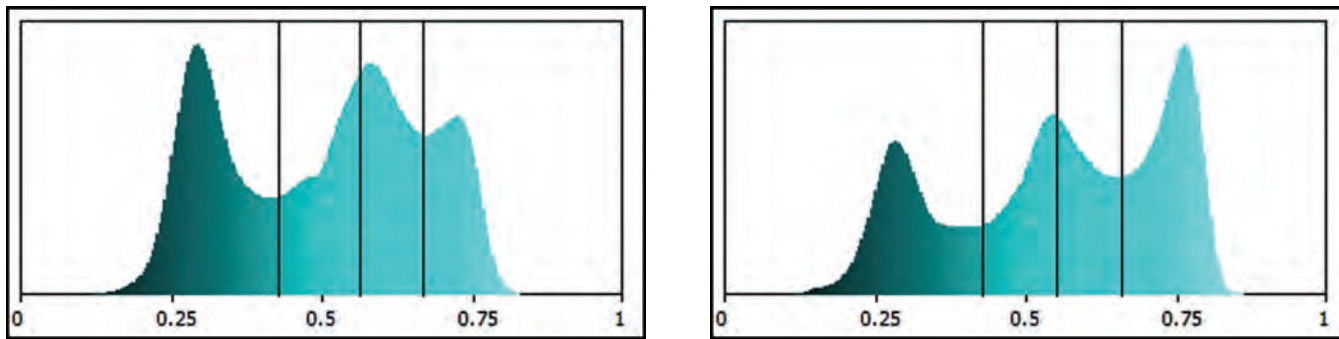

FIGURE 6. Luminance Histogram 2 and Luminance Histogram 3.



FIGURE 7. Included Pixels 2 and Included Pixels 3.

The CIE conducted experiments to determine the DeltaE76 distance above which the colors have a “just noticeable difference”. The distance was determined to be 2.3, which will be referred to “JND” for short. Since the DeltaE76 distance is 4.5 (rounded), it could be concluded the difference between the colors should be noticeable. (Table 2)

Although there is a certain comfort in using a similarity measurement that actually includes all of the pixels in the design, my research has shown there to be little advantage to using them rather than the simpler distances based on the HS-peak. Since their computation requires analysis of the entire HS-histogram, it is much more computationally intensive and requires hours rather than seconds to compute all the distances needed.

TABLE 2. Results of Canon 2 versus Canon 3.

RL Similarity	0.7585
ASUML Sim.	0.7976
DeltaE76	4.4877
Euclidean Dist.	9.3808
Taxi Distance	16
Max Distance	6
HSL Distance	20.1493



## MATCHING OF COLORS TO A COLOR GUIDE

Using the Canon scanner, each of the 600 color swatches in the Michel Color Guide Version 38 were analyzed and their RGB values placed into a color table. An automatic process averaged the R, G, and B values of all the pixels in a large rectangle lying above the hole in the color swatch.

Matching is done by computing a “distance” from the stamp color to each of the colors in the table. The Taxi distance gives a perfect match for all 600 colors in the Michel Color Guide. The Euclidean distance matches 598 out of the 600. These results show that the process described above for extracting the color of the stamp is consistent with the averaging of the RGB values of the selected pixels.

To perform a match with either RL or ASUML, it is necessary to compare the two HS Histograms as well as their average Luminance. This would imply the HS Histogram of each of the 600 colors was stored or the image itself actually reloaded. In the latter case, this would amount to comparing an image with itself and perfect similarity would be assured, which would be a nonsense test. This idea will be revisited later when the storing of actual stamp color data, rather than color from a theoretical color guide, is discussed.

## THE COLOR GRAPH

Given a set of stamp images, a similarity measure and a similarity cutoff, we may construct a graph as follows: The vertices are the images. Two vertices are joined by an edge, provided their similarity is greater than the cutoff value.

As an example of this, consider a set of 32 copies of Mi 37 with cutoff of 0.88 for ASUML. (Figure 8) Coloring will be explained later. Scans of the stamps are included in Appendix 1 which can be found on the IAP website.

## GROUPING STAMPS BY THEIR COLORS

There are three different decomposition algorithms demonstrated here. The first is a decomposition by maximal cliques, the second a decomposition by means of a variation of the K-Means Clustering Algorithm which utilizes centroids instead of means, and the third a non-statistical version of Isodata, referred to as the Split/Merge algorithm.

In Graph Theory, a “clique” is a set of vertices with the property that each pair of vertices in the set are joined by an edge in the graph. It is very natural for a philatelist to think

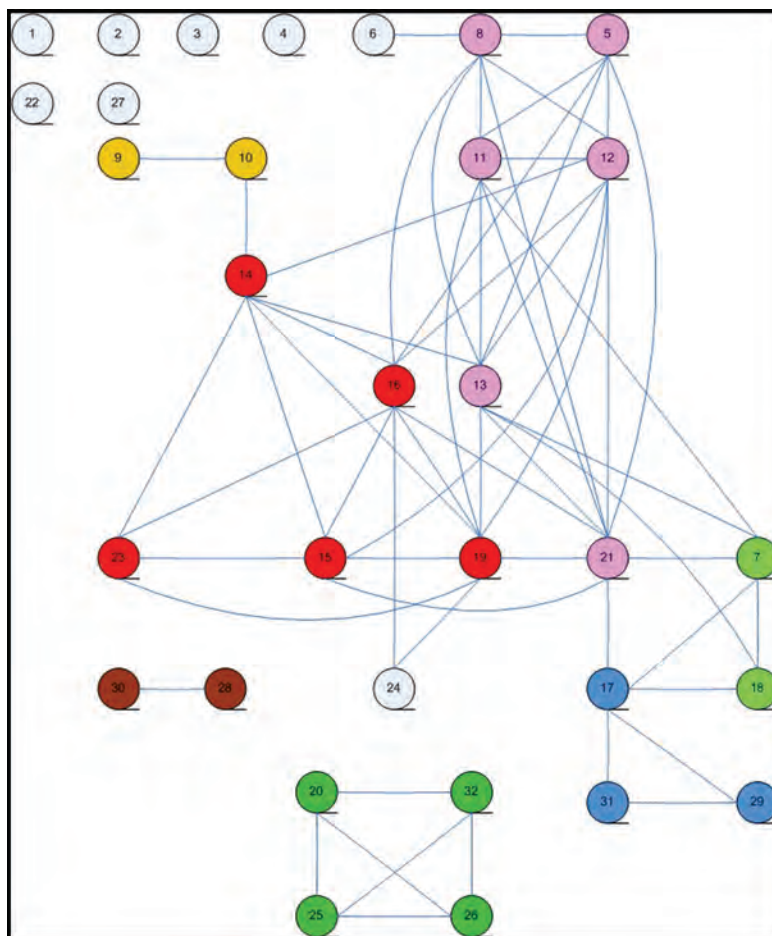

FIGURE 8. Color Graph for 32 Copies of Mi 37 with ASUML at 0.88.

in terms of cliques. If a stamp collector sorts a collection of stamps by color, s/he would place the stamps into piles where each stamp had the same color. This is a clique. If s/he creates a pile that cannot be increased without adding a stamp not the same color as others in the pile, the pile is a maximal clique. Not all maximal cliques are the same size. The stamp collector finds the largest maximal clique there is in the collection. Then, from the remaining stamps, again select a largest maximal clique. Continue until all stamps are sorted into a pile, and you would then have a maximal clique decomposition of the original set of stamps. This decomposition is not usually unique.

There is a well known algorithm for performing this decomposition on a graph, called the Bron-Kerbosh Maximal Cliques Algorithm, which is well-documented and will not be described in this paper.<sup>7</sup> An example of this algorithm applied to the 32 copies of Mi 37 is shown above under “The Color Graph” where the colors indicate the various maximal cliques the algorithm obtains. The uncolored nodes indicate those stamps in a clique with any other stamp. The stamps themselves are shown in Appendix 1.

This decomposition was also performed on a set of 223 copies of Mi 45. The results of this decomposition are shown in Appendix 2, found on the IAP website.

The second way the stamps are grouped is by a variation of the K-Means clustering Algorithm. K-Means clustering is a process of clustering which produces exactly K clusters. K must be specified ahead of time as well as the similarity one is using, but that is all. K of the stamps were chosen to act as initial cluster centers. Our procedure selects these cluster centers so they are well spread out in the set. The rest of the stamps are joined to these K clusters by connecting a stamp to the cluster whose center has the greatest similarity to it. Once this is done, we re-compute the cluster centers and again adjoin the stamps to the cluster with the most similar center. This procedure is repeated until the process stabilizes. In the standard K-Means algorithm, one computes the new cluster center by taking the average of the samples in the cluster. Since such an average would not correspond to an actual stamp in our set and therefore the similarities would not be defined, the new center was chosen as the centroid of the cluster (the stamp which has the highest similarity to all of the stamps in the cluster).

An example of the results of this on the set of 32 copies of Mi 37 is contained in Appendix 1. The results of applying it on the 223 copies of Mi 45 is in Appendix 3, found on the IAP website.

The clusters in Appendix 3 are very homogeneous. Initially, this was a very subjective judgment, until I realized since a measure of “closeness” of colors was being used, it made sense to measure the proximity of the stamps in a cluster to each other, and use this as an objective measurement of the cluster homogeneity. This homogeneity is nothing other than the diameter of the set. The smaller the diameter, the more homogeneous the cluster, K=18 was used to agree with the number of maximal cliques detected in Appendix 2, found on the IAP website.

The results of the Split/Merge clustering algorithm are shown in Appendix 4, found on the IAP website. This algorithm splits a cluster if its diameter exceeds 5.8, and merges two clusters if their centers are within 2.3 of each other. 2.3 is, of course, the “just noticeable difference” of the CIE. 5.8 was chosen since

it is the smallest distance which still yields 18 clusters. The process repeats until no additional splits or merges are performed.

## ASSIGNING COLORS TO THE GROUPS: A COLOR GUIDE

There are two natural ways of assigning a color to each of the groups (cliques or clusters). The first is to average the RGB values of all the stamps in the group. The second is to use the color of the cluster center. This is easily available as a result of the clustering if one is using K-Means or Split/Merge, but is not defined for cliques. But, for cliques, any stamp in the clique is just as eligible to be the center as any other. All stamps in the clique are within the test similarity of each other and so any stamp can serve as the center. Whichever route we choose, we add this group color to our guide and identify it as to its source.

There is a bonus to using a clustering algorithm. A stamp belongs to a cluster if it is closest to its center. So, to determine to which cluster a stamp belongs, we need only test its distance to each of the cluster centers and take the closest. This leads right into the process of matching a stamp to a color guide.

## MATCHING A STAMP COLOR TO THE NEW COLOR GUIDE:

If clustering was based on one of the simple distances defined in “Comparison of Stamp Colors”, we need only store the RGB values of the cluster center in our color table and match a stamp with a color using the same metric.

However, if using either RL or ASUML, we must use the entire HS Histogram of the cluster centers in our comparisons. There are two ways to accomplish this: (1) store the entire HS Histogram (or a part of it) for each of the cluster centers, or (2) store the cluster center stamp image and reconstruct the HS Histogram on demand. Although the second approach is more computationally demanding, it has the advantage of being more easily modified as future demands arise.

In either case, the matching will have the property that all of the stamps in a particular cluster will be matched to its cluster center and thus its color will be properly identified.

## CALIBRATION OF SCANNERS

With my limited experience along these lines, I attempted to find a way to remove the scanner dependency of the results obtained in this paper. Three different scanners were used for this study. I found that calibration using the IT8 Target did not do sufficiently well. I then performed calibrations using the full set of color swatches from the Michel Color Guide. With the limited testing I conducted, this calibration method performed reasonably well. In addition, using the Canon scanner as a standard seemed to be the best choice. The details of this study may be found in *Resolving the Scanner Dependency in Color Matching*, on Page 41 (second paper in Proceedings).

## TOOLS FOR THE ANALYSES

All tools used in the analyses discussed in this paper were written by the author in Borland C++ Builder 2005. Principally, four programs were written: (1) a program that computes the color of a single stamp or compares the colors of two stamps; (2) a program that processes a collection of stamps, forming either cliques or clusters and presenting the results in tabular and scatter plot form; (3) a program for editing stamp information which resides in an auxiliary file; (4) a program for performing homogeneity testing on already constructed clusters.

In addition, there are some auxiliary utilities that serve useful tasks: (1) a scanner interface; (2) a program that allows a scan of many stamps to be broken up into individual images; (3) a program for reading scans of the pages of the Michel Color Guide, creating individual images of each color swatch and creating a color file that contains the (scanner dependent) RGB color data for each swatch, as well as their English and German color names.

Some of these programs exist because it was quickly found repeated selection of the luminance cutoffs and gray level settings would be much too tedious for repeated studies of the same group of images. This gave rise to a Stamp File which contains (for each image in the study) cutoff values, Gray level settings and RGB values.

Since many of the studies performed required comparison of all two by two images, I introduced a Comparison file which contains all of the 2x2 similarity data for a specific measure. For the similarities based on color parameters of either RGB or HSL, these Comparison files are produced fairly rapidly. However, for RL and ASUML, the processing time required on my computer is between 3 and 4 hours. Remember, for 223 images of Mi 45 stamps, there are  $223 \times 222 / 2 = 24,753$  HS Histogram pairs that must be compared. Luckily the program can run in the background while the computer can be used for other purposes. The other tasks are relatively fast once all the preparation has been performed.

At this time, I have not actually implemented a form of the color identification program that matches against representative images. I expect to do this at a later date. Some screen images of the programs are contained in Appendix 5, found on the IAP website.

## CONCLUSION

Although a good deal of this paper is devoted to showing how to handle cancelled stamps, not all stamps can be usefully handled by these processes.

Some stamps are so heavily cancelled or dirty and discolored the objective analysis fails on them. Occasionally, the stamp will show up in a clique/cluster of its own, or more likely, as an oddball in a cluster. When such stamps are encountered it is probably best to remove them from the analysis, however, this was not done in these studies.

Stamps with grey or blackish designs will also not easily be able to have their cancellations removed from the image before processing.

In our studies, we have used all available copies of the

stamp in question. We then attempted to associate each of the clusters with a variety, or a subset of a variety. This did not appear to work well; the probable reason was that we were ignoring other factors such as cancellation dates, uv-characteristics, etc. In practice, one would take a collection of stamps which were previously expertized as belonging to the same color or variety. We would then cluster this set and extract the color (or colors) from the clusters. These colors would be used as the identification colors for that variety.

A question to be studied would be “How close should stamp colors be in order to be considered to have the same color?” As we mentioned earlier, the CIE performed studies to determine a “Just Noticeable Difference” (JND) of 2.3 with the DeltaE76 distance, which is most likely too exacting for comparison of stamps. A study should be performed to determine a “Stamp Just Noticeable Difference” (SJND), which would probably turn out to be somewhere around 5.8.

In summary, I have shown construction of a computer-based, stamp-oriented color guide is not only feasible, but workable. Two tasks remain: (1) obtaining scanner images of a sufficient number of color varieties of the stamps of interest; (2) devising an automatic process of adjusting images on the fly so as to conform to a “standard” scanner. Task 1 requires cooperation from color experts who can provide the images as well as their classifications. Task 2 requires help from someone in the scanner or ink industry who has probably already solved the problem. In my opinion the completion of this goal is long overdue.

## NOTES

1. *Scott Specialized Color Guides for United States Stamps*, Scott Publishing Co., 2005.
2. Darryl Hinton-Blaker, 1998, *Germany 1872-1900 A Philatelic & Postal History Handbook of Germany and her Colonies*, Album Publishing Company, Inc. Raleigh, North Carolina, USA
3. John M. Cibulskis, 2015, Analysis of Color Varieties Using Scanned Images, *German Postal Specialist*, May 2015, Vol. 66 No. 5, Whole No. 720.
4. ‘Color Difference’, Wikipedia, October 24, 2015, [https://en.wikipedia.org/wiki/Color\\_difference](https://en.wikipedia.org/wiki/Color_difference)
5. ‘Histogram Comparison’, OpenCV, [http://docs.opencv.org/doc/tutorials/imgproc/histograms/histogram\\_comparison/histogram\\_comparison.html](http://docs.opencv.org/doc/tutorials/imgproc/histograms/histogram_comparison/histogram_comparison.html)
6. Appendices can be found at [http://analyticalphilately.org/?page\\_id=381](http://analyticalphilately.org/?page_id=381)
7. Alessio Conte, 2013, *Review of the Bron-Kerbosch algorithm and variations*, University of Glasgow School of Computing Science. Accessed October 24, 2015, <http://www.dcs.gla.ac.uk/~pat/jchoco/cliقة/enumeration/report.pdf>



# Resolving the Scanner Dependency in Color Matching

*John M. Cibulskis, Ph.D.*

---

**ABSTRACT.** This paper compares the Color Files created from the Michel Color Guide Version 38 generated from scans made on three different scanners. Cross-calibrations were performed on the scanners using the Color Files, three calibration processes discussed, and the accuracy of the calibrations compared. The ultimate goal is to be able to present the stamp color (or color variety) in terms of its RGB values which can be used by philatelists using a variety of different scanners.

## THE SCANNERS

The following three scanners were used in this study:

- a. Canon LiDE 120 - chosen because of the brand and its low price.
- b. Epson Perfection V600 Photo - purchased as a reasonably good scanner for a fairly good price.
- c. HP Photosmart 6520 - purchased primarily for its printer as part of an All-in-One unit. They will be referred to as Canon, Epson and HP in this paper. The scans were obtained page by page from the Michel Color Guide Version 38 at 300 DPI. An attempt was made to obtain “flat” scans, which did not make use of any of the image enhancement capabilities of the scanner software.

## THE COLOR FILES

The page scans were split into the 600 individual color swatches contained in the guide. Each color swatch was analyzed by my standard Hue-Saturation (HS) color analysis procedure and the results for a single scanner were put into a Color File containing the following information:

- The Michel Color Code in the form I-J-K
- The Color Name in German
- The Color Name in English
- R
- G
- B

The items appear in the file in the same order they appear in the Color Guide. The HS process for extracting the color has been explained elsewhere.<sup>1</sup> These Color Files form the basis for the color matching performed by my software utilities.



## DIFFERENCES BETWEEN THE COLOR FILES

The three Color Files show marked differences in the determined colors of the swatches. Since the color extraction method was the same for each scanner, we can assume the differences are due to the scanner, or at least to the RGB values reported by the three scanners. Figures 1-3 show the images of a single color swatch obtained by the three different scanners.

The slight differences in the heights and the spacing between the images is due to the separation of the page scans into individual color swatches. Cropping the HP image would improve the overall appearance on the page. Note that the “white” page background looks different on the Canon scan.

TABLE 1. Detected RGB Values for the Color Swatch 13-5-6

Scanner	R	G	B
Canon	224	145	62
Epson	247	186	50
HP	229	155	77

Comparisons between the three Color Files were performed. In Figures 4-6, the horizontal axis is the index of the color swatch in the Color Files (that is, the order in which they appear in the Color Guide). The vertical axis is the DeltaE76 error for that swatch. Errors within JND (2.3) are considered to be not noticeable.<sup>2</sup> Errors within 6.0 are considered to be acceptable. Color matching between the color swatches was done using the Taxi metric on the RGB values since this produced the best overall results. There was little difference between the results using the Taxi metric and those using the Euclidean metric on the RGB values. The black points represent correct color matches, the red are incorrect matches.

For example, Figure 4 compares the scans of the color swatches which were made with the Canon and the HP scanners. A table has already been made containing color data for all 600 color swatches as calculated using the HP scanner. Then, for each swatch, the color data from the Canon scanner is compared with the corresponding HP data. The distance between the colors is plotted on the vertical axis. Color match means that given the observed Canon numerical color of the swatch is located to the color in the HP color swatch file that is the smallest distance away. If that HP color swatch is the same as the Canon swatch, it is a correct match and the point is colored black. Otherwise the point is colored red. There is the possibility there are several HP swatches with the same minimum distance to the Canon swatch. In that case, the first such swatch was returned. This may have introduced a false error and nothing was done to eliminate this possibility.<sup>3</sup>

Table 2 summarizes the information displayed in Figures 4, 5 and 6. From this, one can clearly see that the three scanners do not produce compatible results. The Canon and the HP produce the best match and even that is very poor. Only 50 swatches produce colors that are within the JND of each other. Only 282 out of 600 swatches correctly match to the same color in the guide.

TABLE 2. Comparison of the Raw Color Files

Measurement	Canon vs HP	Canon vs Epson	HP vs Epson
Max Error	13.8	31.0	33.2
Avg Error	4.9	12.3	12.2
Within JND	50	6	18
Within 6.0	448	62	84
Correct Matches	282	116	134



FIGURE 1. Canon.



FIGURE 2. Epson.



FIGURE 3. HP.

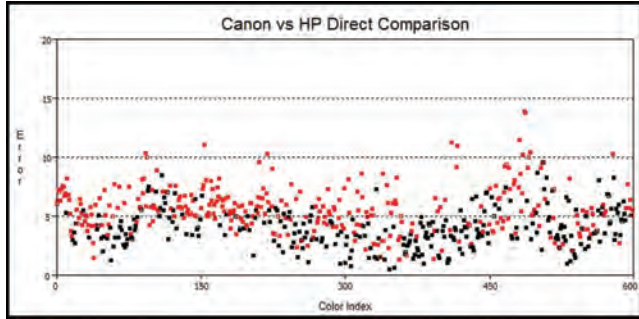

FIGURE 4.

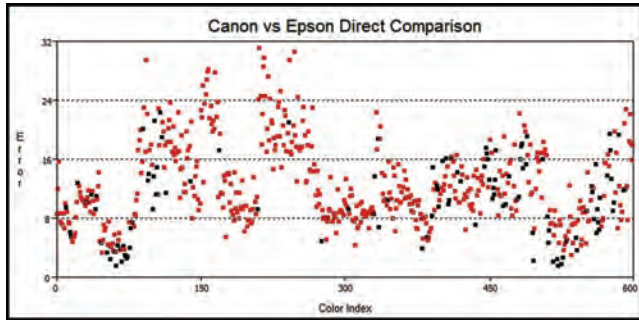

FIGURE 5.

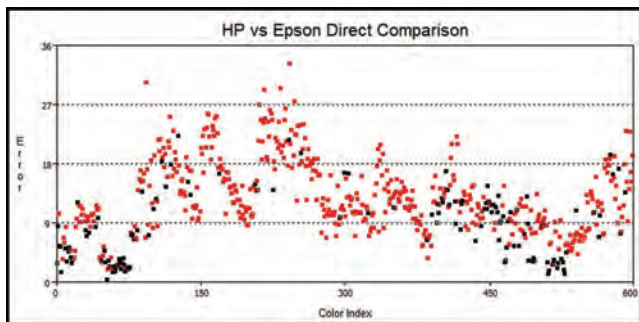

FIGURE 6.

For illustration with the three images of 13-5-6, Table 3 contains the DeltaE76 distances between the swatches. Note that the distances are less than the maximum errors noted in Table 2. This indicates that this swatch is not the worst color match between the scanners.

TABLE 3. DeltaE76 Distances between Images of 13-5-6

	Canon	Epson	HP
Canon	0.0	24.7	5.5
Epson	24.7	0.0	24.9
HP	5.5	24.9	0.0

### THE COLOR MODELS

Four different color models were utilized in our study.

a) HSL:

This is the Hue-Saturation-Luminance color model previously discussed.<sup>4</sup> It is the source of our color information since the techniques utilize this model to extract the color from the stamp design.

b) RGB:

This is the Red-Green-Blue color model which is the method by which the information is initially extracted from the scanner.

c) CIE XYZ:

This is a linearization of the RGB model, originally defined by the CIE group. It is meant to be device-independent, and will only be used as an intermediate model between RGB and Lab.

d) CIE Lab (or  $L^*a^*b^*$ ):

This is another device-independent model defined by the CIE group.  $L^*$  is the Lightness (or Luminance) ranging from 0 to 100.  $a^*$  is the red-green axis and  $b^*$  is the yellow-blue axis. True neutral-gray occurs for both  $a^*$  and  $b^*$  at zero. Positive  $a$  yields shades of red, negative  $a$  shades of green. Positive  $b$  yields shades of yellow, negative  $b$  shades of blue. The limits of the  $a^*$  and  $b^*$  axes depend upon the particular implementation, but are usually -100 to 100 or -128 to 127.

Conversions from one color model to another will always be in the following orders:

$$\text{HSL} \leftrightarrow \text{RGB} \leftrightarrow \text{XYZ} \leftrightarrow \text{Lab}$$

To obtain Lab coordinates from HSL coordinates, HSL is first converted to RGB, then from RGB to XYZ and finally from XYZ to Lab.

We shall not go into the formulas for these conversions here. Good sources for formulas for these conversions and color models may be found in Wikipedia.<sup>5</sup>

### THE TRANSFORMATIONS

As seen in section on differences between color files, it is necessary to find a conversion of the RGB values obtained from one (local) scanner to those obtained (possibly by someone else) through use of another (standard) scanner. The ability to do this means we can obtain the color of a stamp from a scan by our local scanner, convert it to the standard scanner and

utilize color parameter information obtained through the use of the standard scanner.

We have investigated linear, quadratic and cubic mappings from local Lab to standard Lab. Each of these is really a mapping from Lab to either L, a, or b. That is, each transformation may be viewed as a set of three mappings, one mapping Lab to L, another from Lab to a, and the third from Lab to b. For example, for the linear case, the three functions are:

$$\begin{aligned} \text{standard L} &= FL(L,a,b) = c1 \times L + d1 \times a + e1 \times b + f1 \\ \text{standard a} &= FL(L,a,b) = c2 \times L + d2 \times a + e2 \times b + f2 \\ \text{standard b} &= FL(L,a,b) = c3 \times L + d3 \times a + e3 \times b + f3 \end{aligned}$$

where the Lab values on the right of the equalities are the measured local Lab.

The linear functions were found to be insufficient; the quadratic were found to have unacceptable behavior. The cubic equations were found to be useful by this study and many authors in the past. Each of the cubic functions contains 20 terms. Each of the equations was fit to the data with least squares fitting by Cholesky factorization.

Three basic approaches were studied.

### A SINGLE EQUATION

Use a single transformation from local color coordinates to standard color coordinates. We restricted ourselves to a mapping from the local Lab color space to the standard Lab space. In this case, a single cubic function defined on all of local Lab were used.

### MULTIPLE DOMAINS

Break up the local color coordinate space into several non-overlapping areas and define a (possibly different) transformation on each of these areas. These mappings are from subsets of the local Lab color space to the standard Lab space. This process is referred to as "L8." In this case, local Lab was partitioned into eight octants defined by the condition the three coordinates be positive or negative. A local Lab value is first checked to see in which of the eight octants it lies. A separate least squares fit was done for each of the octants.

### PRE-PROCESSING

Define the transformation(s) directly from the local RGB coordinates after applying a pre-processing step. These transformations were guided by a suggestion from Hardeberg.<sup>6</sup> He suggested using pre-processing on the local RGB values by taking their cube roots. He then maps the pre-processed RGB values directly to the standard Lab space using cubic transformations. This approach was tested with both a single equation and with L8. The results are comparable to just using either a single equation or multiple domains as described above. There may be an efficiency advantage to Hardeberg's approach but that is not investigated here.

The following charts and tables show the results of the different basic approaches.

## FROM LOCAL TO STANDARD CANON AS STANDARD

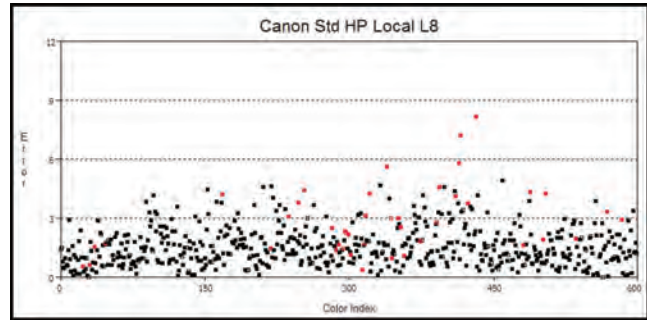

FIGURE 7.  
FIGURE 8.

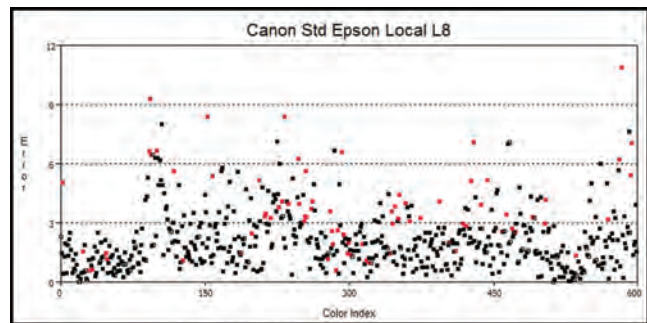
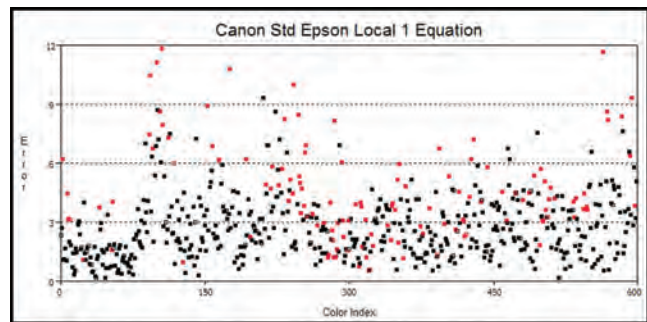

FIGURE 9.  
FIGURE 10.

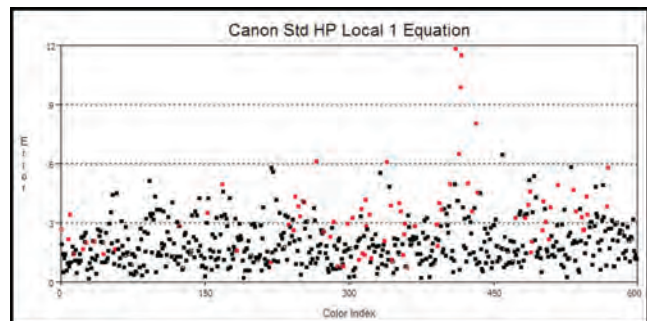



TABLE 4. Canon as Standard 1 Equation.

	Epson as Local	HP as Local
Max Error	11.8	11.8
Avg Error	3.1	2.1
Within JND	254	386
Within 6.0	549	592
Correct Matches	471	519

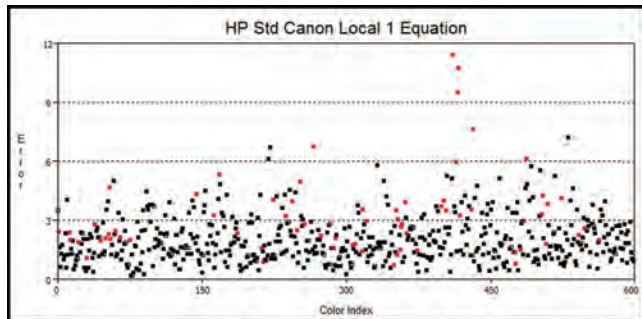
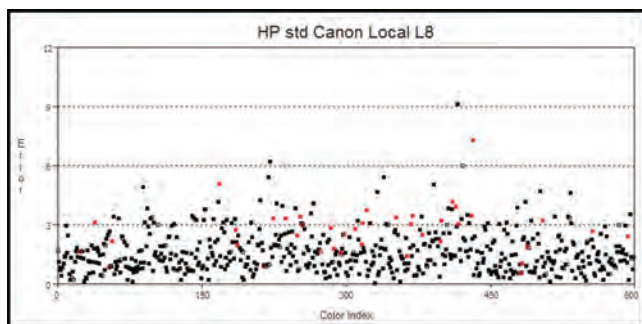

FIGURE 13.  
FIGURE 14.

TABLE 5. Canon as Standard L8.

	Epson as Local	HP as Local
Max Error	10.9	8.2
Avg Error	2.2	1.6
Within JND	377	476
Within 6.0	577	598
Correct Matches	523	558



HP AS STANDARD

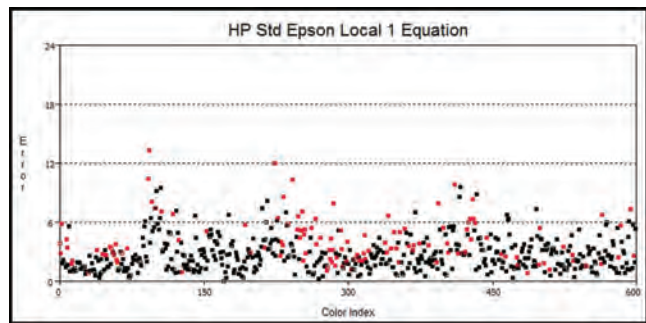

FIGURE 11.  
FIGURE 12.

TABLE 6. HP as Standard 1 Equation.

	Epson as Local	Canon as Local
Max Error	13.4	11.4
Avg Error	3.0	2.2
Within JND	267	380
Within 6.0	554	591
Correct Matches	471	530

TABLE 7. HP as Standard L8.

	Epson as Local	Canon as Local
Max Error	11.7	9.1
Avg Error	2.3	1.7
Within JND	352	457
Within 6.0	582	597
Correct Matches	510	560

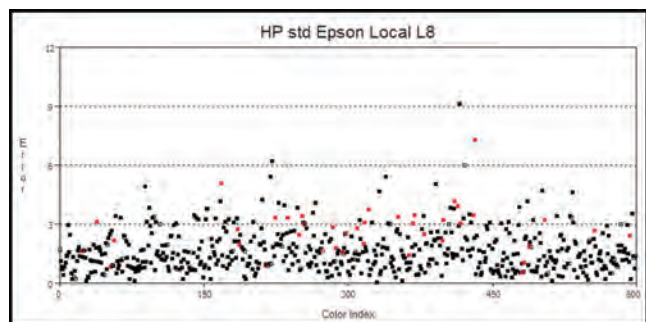

EPSON AS STANDARD

Given the results for Canon and HP as standards, obtaining results for Epson treated as the standard was not pursued, as it would not be a good standard for either Canon or HP local scanners.

HP STANDARD WITH HARDEBERG'S VARIATION

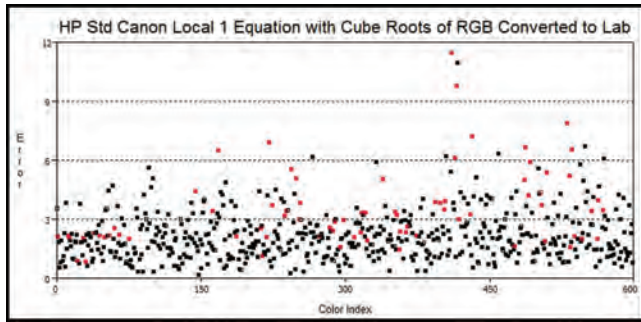

FIGURE 15.  
FIGURE 16.

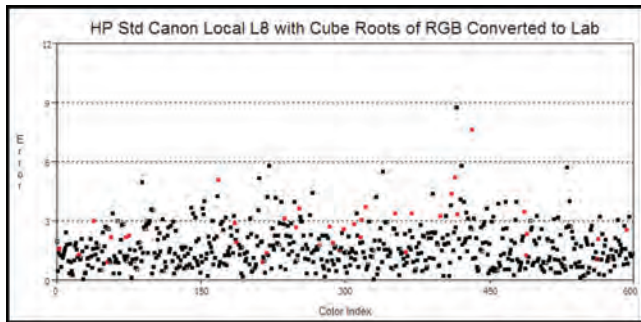

TABLE 8. HP as Standard 1 Equation - Hardeberg.

	Canon as Local
Max Error	11.4
Avg Error	2.3
Within JND	364
Within 6.0	585
Correct Matches	524

TABLE 9. HP as Standard L8 - Hardeberg.

	Canon as Local
Max Error	8.7
Avg Error	1.7
Within JND	455
Within 6.0	598
Correct Matches	562

The results using Hardeberg's approach are very close to the results of using only L8 with HP as standard and Canon as local.

As strange as it may seem, the best results were obtained with the inexpensive Canon scanner as the standard using the L8 process. However, more tests with other scanners should be

performed before deciding upon using this scanner as the standard. In addition, the low price of this Canon model raises the question of how durable the scanner will be with heavy usage.

**RESULTS OF CALIBRATION**

To see the results of the calibration, the original three images of 13-5-6 after conversion by L8 with Canon as the standard (the Canon image is unmodified) are shown.

The top row shows the original images, the second row the converted images.

TABLE 10. Converted RGB Values for the Color Swatch 13-5-6 using L8 with Canon as Standard.

Scanner	R	G	B
Canon	224	145	62
Epson	225	147	57
HP	224	144	62

TABLE 11. DeltaE76 Distances between Converted Images of 13-5-6 using L8 with Canon as Standard.

	Canon	Epson	HP
Canon	0.0	11.0	3.6
Epson	11.0	0.0	7.8
HP	3.6	7.8	0.0

TABLE 12. DeltaE76 Distances between Original Images of 13-5-6.

	Canon	Epson	HP
Canon	0.0	24.7	5.5
Epson	24.7	0.0	24.9
HP	5.5	24.9	0.0

The distances between the images were decreased substantially. However, the Epson image still appears substantially different. As an interesting additional point, 13-5-6 matches correctly to the Canon standard with both of the other local scanners after conversion.

**SUMMARY**

Scanner calibration using the Michel Color Guide is feasible and effective. The best results were obtained using the L8 transformation scheme with cubic mappings from Lab to Lab and the Canon scanner as the standard. With this scheme used for an HP as a local scanner, 598 of 600 color swatches compared with a DeltaE76 distance of less than 6.476 were within JND (2.3). A total of 558 out of 600 swatches were correctly matched. The Epson as local scanner did not do as well with only 523 swatches correctly matched.





FIGURE 17. Canon.



FIGURE 18. Epson.



FIGURE 19. HP.



FIGURE 20. Canon.



FIGURE 21. Epson.



FIGURE 22. HP.

### NOTES

1. John M. Cibulskis, Analysis of Color Varieties Using Scanned Images, *German Postal Specialist*, May 2015, Vol. 66, No. 5, Whole No. 720, pp 201-220.
2. “Color Difference”, Wikipedia, October 24, 2015, [https://en.wikipedia.org/wiki/Color\\_difference](https://en.wikipedia.org/wiki/Color_difference)
3. One common feature of modern software plotting systems is they automatically scale. However, in comparing two plots, that rescaling often hides the point that is trying to be made. I wrote the plotter software and embedded into the program that calculates the cubics. When I generated the images, it did not occur to me to use a common vertical axis though I see now that it would make the differences clearer. On the other hand, it would cause some of the plots to be significantly “squished-down” to the bottom and not allow as much

- differentiation of the individual data points. I did not change the program. A future paper will address this issue.
4. John M. Cibulskis, Towards a Stamp-Oriented Color Guide: Objectifying Classification by Color, *Proceedings of the Second International Symposium of Analytical Philately*, to appear.
5. “Color conversion math and formulas”, EasyRGB, 2014, <http://www.easyrgb.com/index.php?X=MATH&H=08#text8>; “sRGB”, Wikipedia, October 20, 2015, <http://en.wikipedia.org/wiki/SRGB>
6. Jon Hardeberg. Acquisition et reproduction d’images couleur: approches colorimétrique et multispectrale. Human-Computer Interaction. Telecom Paris-Tech, 1999. French. <tel-00005657> (Ph.D. Thesis)



# Ink Composition of the U.S. 3¢ stamps of 1870-1883

*John H. Barwis and Harry G. Brittain*

---

**ABSTRACT.** This paper describes laboratory research conducted on the United States 3¢ issues of 1870, 1873, 1879 and 1881 (Scott catalog numbers 136, 147, 158, 184, and 207, respectively). The goal of this work was to understand color variation in the “3-cent greens” in terms of the chemical components of the printing inks used by the three printing contractors involved. Analyses included measurement of relative spectral reflectance, identification of elements using X-ray fluorescence, and identification of compounds using Fourier-transform infrared fluorescence. Results demonstrate that the same pigments were used in the inks of all three contractors, and that the hues observed result from relative concentrations of these pigments as well as the proportions of ink extenders and brighteners. The type of paper used probably contributed to the brightness or dullness of a stamp, but this effect has not been quantified.

## INTRODUCTION

Between 1870 and 1883 more than 6.6 billion 3-cent stamps were issued by the United States Post Office, more than any previous American adhesive (Luff, 1902). All were printed in green by three private companies under government contracts. The 2013 Scott catalogue lists 16 shades of green for these stamps (Scott, 2012), most of which exhibit slight variation: bright vs. dull, and pale vs. deep. The listed shades are shown in Table 1. Although the color green was specified by the Post Office Department for these stamps, the Third Assistant Postmaster General’s correspondence (the so-called *Travers Papers*) revealed no intent to influence ink formulas or shades.

Two questions were addressed by this study:

- Did the three companies employ the same ink pigments, or were different pigments introduced, especially with regard to the rarer shades such as yellow-green and olive-green?
- What contributed to the relative dullness of a stamp, compared to a brighter stamp of the same hue, especially with regard to the re-engraved design printed by the American Bank Note Company?

## THE PRINTING CONTRACTS

Three companies worked under four printing contracts over 13 years (Table 2) to produce four varieties of 3¢ stamps, as illustrated in Figure 1. With few exceptions these types are relatively easy to identify with a 10x hand lens. Paper types vary between and within each of the printings (Barwis, 2013); those variations are beyond the scope of this study.

The Scott-listed colors in Table 1 are a more than adequate compilation for most collectors, although a specialist could easily expand this number in a color chart showing



FIGURE 1. The four types of the large 3¢ Bank Note Company stamps.

TABLE 1.

National	Continental	American	American Re-engraved
Green	Green	Green	Blue Green
Pale Green	Bluish Green	Dark Green	Green
Dark Green	Yellow Green	Light Green	Yellow Green
Yellow Green Dk.	Yel. Green		
	Dark Green		
	Olive Green		

TABLE 2.

Contract Awardee	Contract Period	Comments
National Bank Note Co.	1869-1873	Bid design changed in 1870
Continental Bank Note Co.	1873-1877	Design remained the same
Continental Bank Note Co.	1877-1881	Contract novation in 1879 after consolidation
American Bank Note Co.	1881-1885	Re-engraved design

gradations. The color nomenclature can be confusing to someone unfamiliar with these issues. For example, the American Bank Note Company’s yellow-green bears no resemblance to the yellow greens printed during the National and Continental contracts. Similarly, Scott does not mention a light green printed by the Continental Bank Note Company, although it is actually paler than light green stamps printed by the National Bank Note Company. However, the list in Table 1 is sufficient for determining the principal components of the inks used by all three companies.

**DATA COLLECTION**

From an unsorted group of several thousand used, off-cover 3¢ stamps, 53 were chosen to represent the range of

shades exhibited by these issues. Each stamp was numbered so data collected could be linked to unique samples. The general range of shades studied is shown by the eleven groups in Figure 2. Multiple examples of each shade were examined which together more than encompass all 16 of the Scott-listed shades.

All testing was non-destructive. Reflectance and X-ray fluorescence (XRF) were measured by the author and Tom Lera at the Smithsonian National Postal Museum. Compounds were detected and identified by Harry Brittain using Fourier-transform infrared (FTIR) spectroscopy and attenuated total reflectance (ATR) sampling. It is important to recognize that the XRF instrument detects everything within its beam path through the entire thickness of the stamp, including components of the stamp paper. Those components include the fibers from which the paper was made, as well as any chemicals used as filler or sizing.





FIGURE 2. Selected examples of the shades tested in this study. Variations within each of shade were included, consistent with the Scott-listed colors.

The attenuated total reflectance sampling technique for Fourier-transform infrared fluorescence examination is a surface measurement, as the beam does not penetrate the entire stamp. But as the data clearly show, elements of paper composition were detected because the areas sampled were not completely ink-covered.

#### REFLECTANCE SPECTROSCOPY

Spectral reflectance data were collected for near ultraviolet into infrared wavelengths (400-900 nm) using a Foster & Freeman Video Spectral Comparator (VSC 6000). Each stamp was placed under the light source and enlarged by a factor of eight, which allowed measurement of the average reflectance from an area of about 0.2 mm<sup>2</sup>. Areas of thickest ink (e.g., in the oval medallion), but away from a cancellation, were measured three times for each stamp, and the results per stamp were averaged.

#### X-RAY FLUORESCENCE

X-ray fluorescence to determine metal content was also measured at the National Postal Museum, using a Bruker Tracer III-SD with a rhodium X-ray tube with a silicon drift detector that has a resolution of 145 eV and a sample-spot size of about 0.5 mm<sup>2</sup>. Spectra were acquired at a voltage of 40 eV, a beam current of 6 μA and an exposure time of 60 seconds per sample.

#### FOURIER-TRANSFORM INFRARED ABSORPTION

Fourier-transform infrared absorption spectra were obtained at a resolution of 4 cm<sup>-1</sup> using a Shimadzu model 8405

FTIR spectrometer. The data were acquired using the attenuated total reflectance sampling mode (ATR), in which the samples were clamped against the ZnSe crystal of a Pike MIRacle™ single-reflection horizontal ATR sampling accessory. This device enabled study of a stamp surface area of about 1 mm<sup>2</sup>, and accentuates sampling of the surface.

## RESULTS

#### REFLECTANCE SPECTROSCOPY

Spectral reflectance data for each of the 16 shade groups in Figure 2 are illustrated in Figure 3, with each line on the chart representing the average of several stamps from each group. The intensity of reflectance increases upward on this chart. The wavelength of the source light increases from ultraviolet on the left to infrared on the right. Note that in the visible and near infrared parts of the spectrum (400-700 nm) the 16 reflectance curves are nearly parallel. Their principal differences are in total reflectance – a proxy for what the eye sees as relative brightness or dullness of a stamp.

Collectors of these stamps are well aware that brightness varies widely between the four varieties, a characteristic depicted by Figure 4. Reflectance trends vary between printings: National and Continental stamps are closely similar in the visible spectrum, but National stamps are far more reflective of infrared light. Continental and American stamps are very similar, except for one dull American shade. American re-engraved stamps are

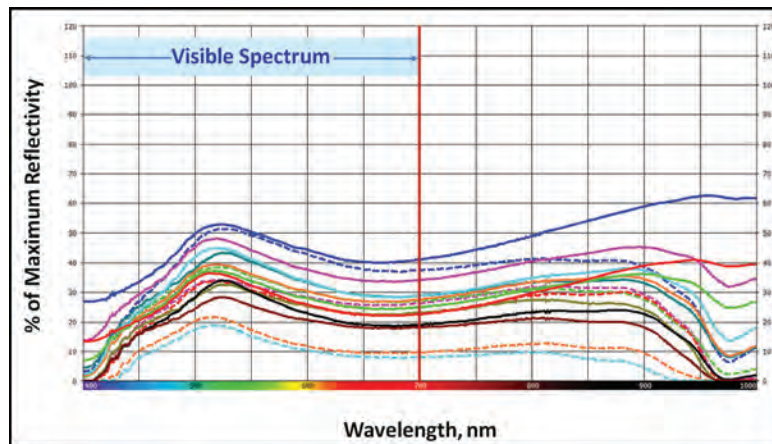

FIGURE 3. Reflectivity curves, plotted as averages of each of the 16 shade groups tested.

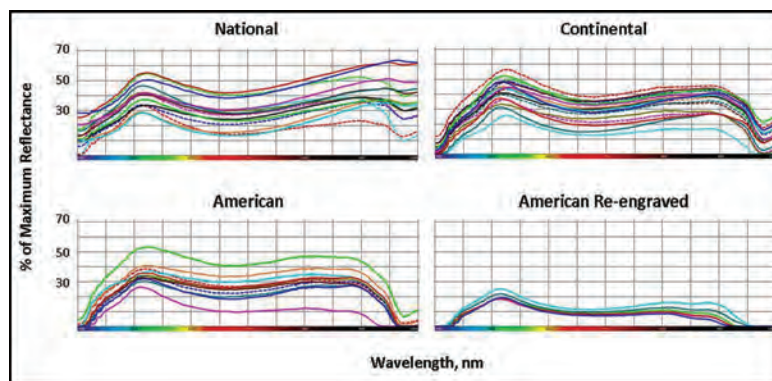

FIGURE 4. Reflectivity curves for all 53 of the individual stamps tested. The re-engraved stamps are all dramatically less reflective.

on average roughly half as reflective as the other three printings.

For a given ink the principal influences on reflectivity are:

- Thickness of an ink layer: thinner layers are relatively more reflective.
- Types of brighteners used in paper manufacturing.
- Whiteners and extenders used in ink recipes.
- Particle size of pigments with respect to ink whiteners.

Brighter colors can be produced using finer pigment-particle sizes, especially for translucent pigments.

We have not attempted to quantify the causes of relative brightness in these stamps, although general trends will be discussed with regard to the FTIR data.

#### X-RAY FLUORESCENCE

To understand ink chemistry, we compared the presence of metals in inks used by the three printing companies. Each of the three histograms in Figure 5 represents an average of each company's stamps. Photon counts are an approximation of relative abundance of an element, not their concentration,

because heavier metals emit more photons relative to lighter metals when excited by an X-ray beam. For example, in a given set of samples from one printing, chromium and lead may be present in equal proportion despite different photon counts. Conversely, comparing a single element's photon counts between printings does indicate relative abundance within the two printings being compared. Three important aspects of the Figure 5 data are:

- National stamps contain greater than 50% more zinc than Continentals, whereas Americans contain only trace amounts.
- Continentals contain more than twice as much calcium as the Nationals, but less than half as much as the Americans.
- Continental stamps contain more chromium, iron, lead, and sulfur than both Nationals and Americans.

It is clear that the three companies used different ink recipes. To understand how the ink components control color, we turn to the FTIR data.

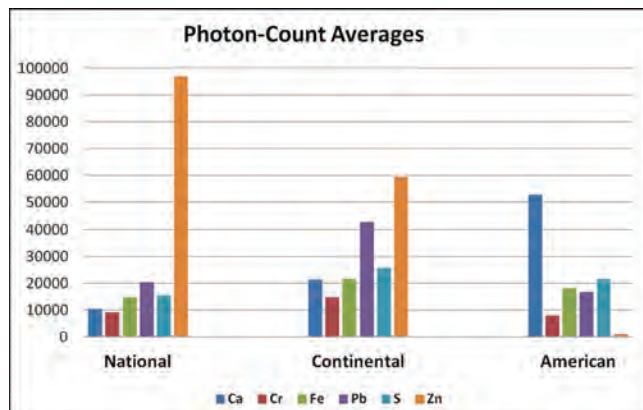

FIGURE 5. Elements present based on XRF data, averaged for the stamps of each printing company. Photon counts indicate presence of a given element, not its concentration with respect to other elements in the same sample.

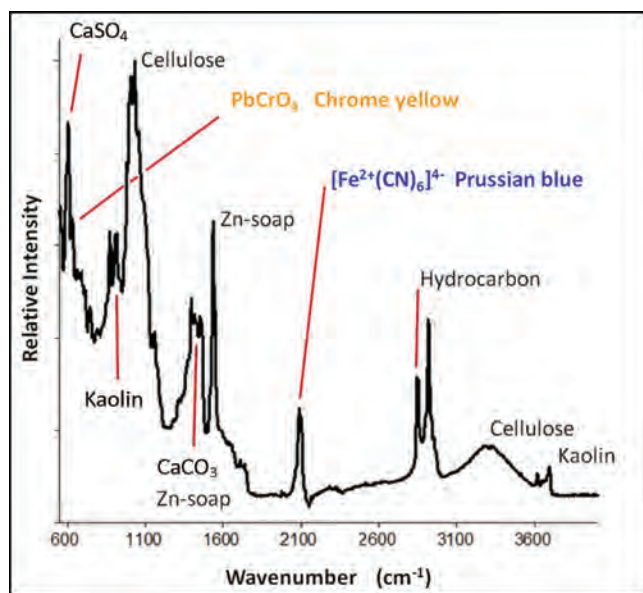

FIGURE 6. Composite of all FTIR data for the National Bank Note Co. issues, with all the peak assignments.

#### FOURIER-TRANSFORM INFRARED ABSORPTION

Compounds detected in the National Bank Note Company stamps are depicted in Figure 6. In this chart the area under each peak is effectively proportional to the relative concentration of a given compound. This chart shows that National's green ink was made by combining the mineral chrome yellow (crocoite:  $\text{PbCrO}_4$ ) and the man-made pigment Prussian blue ( $\sim\text{Fe}^{2+}[\text{CN}]_6^{4-}$ ). The cellulose peaks are due to the cotton fibers comprising the paper on which the stamps were printed.

Four other minerals are present in these stamps. Calcium sulfate ( $\text{CaSO}_4$ : anhydrite) is commonly used as a filler and

coating agent in paper manufacturing. Calcium carbonate ( $\text{CaCO}_3$ : calcite) is used both as a filler in paper manufacturing and as a whitener/extender in ink manufacturing. Zinc-soap is most likely the result of saponification of zinc oxide ( $\text{ZnO}$ : zincite) by the hydrocarbon component of the ink. This component was most likely linseed oil, commonly used in the 19<sup>th</sup> Century as a vehicle and binder for manufacturing printing ink. Kaolin ( $\sim\text{Al}_2\text{Si}_2\text{O}_5[\text{OH}]_4$ ) is a family of clay minerals sometimes used as a filler in paper manufacturing.

National's different hues resulted from variations in the relative proportions of chrome yellow and Prussian blue. Note that in Figure 7, National's yellow-green shade contains a higher ratio of chrome yellow to Prussian blue than in the dark green shade. Pale green has a higher proportion of zinc-soap than either of the other two shades (Figure 8).

Continental 3¢ stamps display an even broader range of hues than the Nationals, differences which were also caused by altering the mix of chrome yellow and Prussian blue. Earlier shades were relatively pale, typified by the bottom two stamps in Figure 9. Later shades were deeper and more vibrant, and included the top two stamps in Figure 9. Notice that both the dark green shade and the olive green shade contain about the same amount of chrome yellow pigment, but in the dark green shade the yellow contribution is overwhelmed by a much higher concentration of Prussian blue, whereas the earlier, lighter shades contain less Prussian blue relative to the deeper shades. Note also that Continental increased the proportion of the brighteners zinc oxide and calcium carbonate.

All stamps identified as American Bank Note Company printings appear dull or washed-out compared to previous issues. As shown in Figure 10, these inks contained the same low concentrations of Prussian blue as the lighter shades of the Continental printings. Zinc-soap is absent, but much higher proportions of calcium carbonate were used as a whitener, resulting in a somewhat milky appearance.

#### DISCUSSION

What drove the evolution of ink compositions in this series of stamp issues? Printing costs were undoubtedly an important concern. The costs of pigments, especially Prussian blue were more expensive than the mineral fillers and whiteners such as calcium sulfate and calcium carbonate which were, and still are, relatively inexpensive commodities. We were unable to find 1870s same-year comparable prices for the pigments described here, but prices published later provide insight to their relative values. For example, prices current in New York were 5¢/lb for powdered calcium carbonate, 7½¢/lb for zinc oxide, 24¢/lb for chrome yellow, and 50¢/lb for Prussian blue (Prices Current, 1922). Calcium carbonate (limestone) is common and easily quarried; lead chromate (crocoite) is uncommon, and Prussian blue is not naturally occurring so must be manufactured.

The earliest deliveries of 3¢ stamps from the Continental Bank Note Company (the bottom two stamps in Figure 9) were not well received, as expressed in the *American Journal of Philately* for August 15, 1873 (page 126):

*"The difference is easily noticed without the aid of the Company's imprint, the colors being paler than heretofore, and of a slightly washy appearance."* (Luff, 1902)



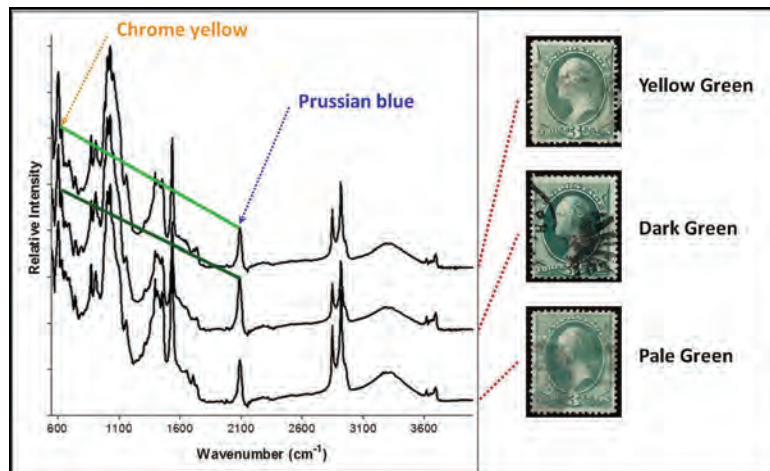

FIGURE 7. Relative content of chrome-yellow versus Prussian blue pigments in yellow-green versus dark green National Bank Note Co. stamps. Curves have been plotted in an offset fashion to make them clearer.

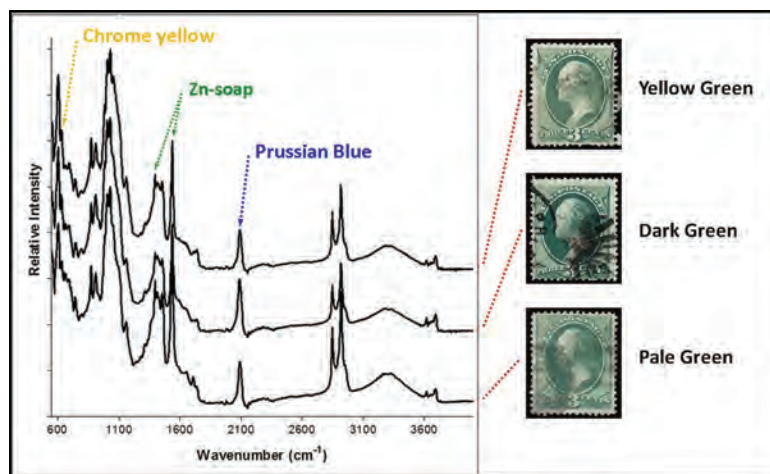

FIGURE 8. Relative content of zinc-soap in green inks used by the National Bank Note Company. Curves have been plotted in an offset fashion to make them clearer.

The company responded by printing a range of deeper shades (Barwis, 2001). It may have been these costs which led the company to complain to the Third Assistant Postmaster General about unsustainable profit margins.

February 1879 saw consolidation of the American, National and Continental Bank Note Companies, along with seven other smaller companies (Griffiths, 1959). The “new” American Bank Note Company – as the consolidated entity was named – reduced postage-stamp unit production costs in part by using less expensive paper (Barwis, 2013), reverting to smaller proportions of Prussian blue in their ink recipe, and eliminating the use of zinc oxide as a brightener.

## CONCLUSIONS

All tested inks of the 3¢ large bank-note issues proved to be mixtures of chrome yellow and Prussian blue pigments. Deeper shades contain relatively higher concentrations of Prussian blue. All printings used calcium carbonate ( $\text{CaCO}_3$ ) as a whitener. Both types of American Bank Note Company stamps contain the highest concentrations of calcium carbonate and the absence of zinc, which resulted in “washed-out” hues.



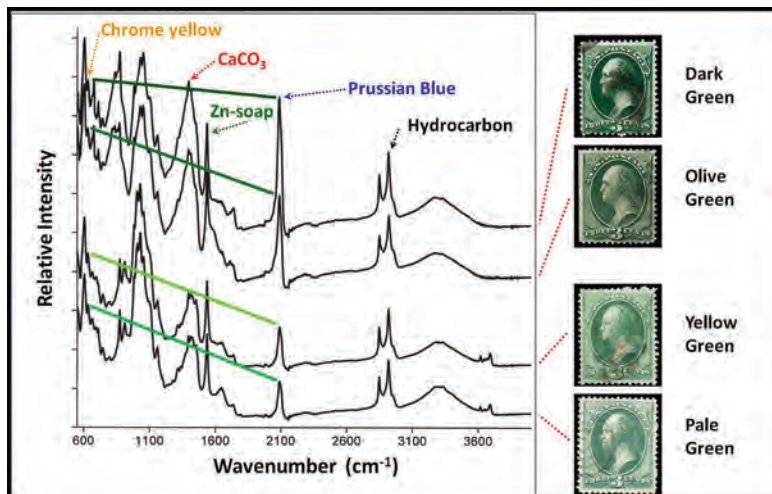

FIGURE 9. Relative content of chrome-yellow versus Prussian blue pigments of Continental Bank Note Company Stamps between the early pale shades and the later deep shades. Curves have been plotted in an offset fashion to make them clearer.

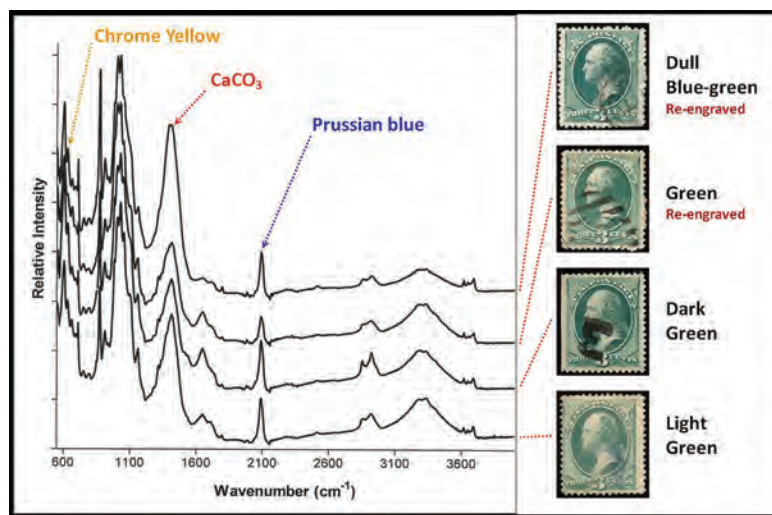

FIGURE 10. Relative content of chrome-yellow versus Prussian blue pigments for American Bank Note Company stamps. Note the absence of zinc-soap. Curves have been plotted in an offset fashion to make them clearer.

## ACKNOWLEDGEMENTS

We are grateful to James Allen for providing stamps for analyses, and for sharing his knowledge of the chemistry of papermaking and ink manufacturing. Special thanks go to Michael Plett for his incisive review of the text and for clarifying details of the American Bank Note Company's business in the 1870s.

## REFERENCES

- Barwis, J.H., 2001. "United States Three-Cent Continental: Date Ranges of Varieties." *In Sixty-Seventh American Philatelic Congress*, pp. 1-19. Chicago: American Philatelic Congress.
- Barwis, J.H., 2013. "Paper Characteristics of U.S. 3¢ Stamps, 1870-1881." *In Proceedings of the First International Symposium on Analytical Methods in Philately*, pp. 5-18. Washington: Smithsonian Institution Scholarly Press.
- Griffiths, W.H., 1959. *The Story of American Bank Note Company*. Prices Current, 1922. Chemical, Color and Oil Record, Vol. 17, No. 3, p 20. New York.
- Luff, J.N., 1902. *The Postage Stamps of the United States*. p. 97. New York: Scott Stamp and Coin.
- Scott Publishing Company, 2012. *Specialized Catalogue of United States Stamps and Covers*, pp. 38-43. Amos Press: Sydney, Ohio.
- Williams, M.A., Ferrell, M.M., and Baker, J., 1994. Technology and Conservation of Decorative Surface Systems of Horse-Drawn Vehicles. *In Painted Wood: History and Conservation*, p. 349. Los Angeles: The Getty Conservation Institute.

# Digital Image Differencing of High Resolution Stamp Images

*Robert Mustacich*

---

**ABSTRACT.** A new method for comparing high resolution stamp images allows the direct subtraction of the raw data of one image from another to reveal small differences over the entirety of the stamps. The method corrects for small differences in size, orientation, color, and also spatial distortions resulting from uneven paper shrinkage. Minor printing-plate differences, arising from die re-entries or other plate flaws, can be easily visualized over the entirety of the stamp. In addition, the image corrections provide a means to directly compare the intrinsic differences between plate impressions. The intra-sheet differencing of stamp images gives reproducible comparisons which appear to be relatively independent of paper shrinkage. This indicates that these are direct measurements of the differences in the plate impressions created by the transfer roll in the production of the plates.

## INTRODUCTION

Analysis of digital images gives us a deeper understanding of the stamps that we collect. Direct manipulation of raw image data has been used to visualize features such as a cancel, watermark, or gum disturbance. A variety of software is available which makes changes to color balance, contrast, or overlay transparencies.<sup>1</sup> Comparing ink colors may be done by complex spectrophotometric equipment, or by a simple desktop scanner (Lyerla, 2014). We can gain additional visual information about small changes in images using a blink comparator, a method used in astronomy that was developed more than a century ago (Zeiss, 1904). In this approach, small differences between two images can be quickly noticed by rapidly switching between two aligned images.<sup>2</sup>

A more in-depth comparison of two stamp images might be produced by directly subtracting the raw data of one image from another but, until this time, this procedure was not available. Significant difficulties provided obstacles. First, images of two stamps need to be aligned for comparison, but this is very problematic because the image differs in placement, size, and rotation. Next, unequal paper shrinkage causes large variation in the print size of each stamp. Third, a significant spatial variation in scanning results from both mechanical variations in the moving parts of the scanner, as well as distortions and imperfections in the scanning hardware and optics. Fourth, slight differences in the stamp color introduce additional variation in the digital data. Lastly, microscopic variation in the creation of a digital image depends upon the alignment of the stamp's details with the optical sensing elements.

While this set of difficulties is formidable, it is not insurmountable. It has proved possible to develop a method which gives reasonable and reproducible subtraction of high resolution images. This method provides a new way to investigate the detailed differences between stamp images, and even the printing plates themselves.



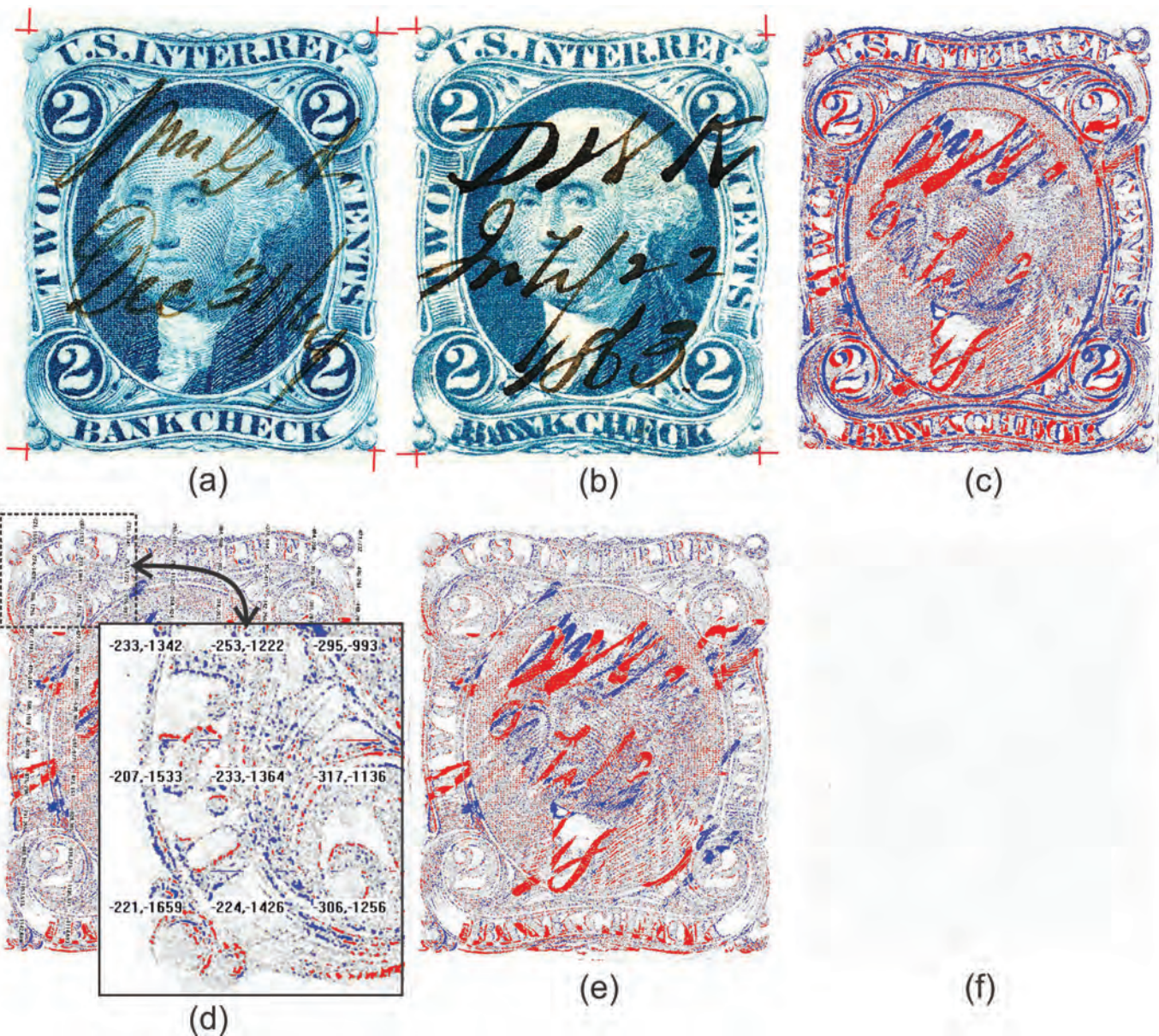

FIGURE 1. The sequence of image processing steps for subtraction is illustrated above for the comparison of the First Issue blue Bank Check Documentary revenue stamp and its “T5” re-entry. The re-entry shown in (b) is visible in the doubling of features and lettering at the bottom of the stamp. A brief description of the steps: (a) A 1200 dpi high contrast image analyzed from all four edges inward to find the outer edges of the design and fit lines to the edges; the intersections of the four lines result in the cross-hair patterns to accurately determine the corners; (b) the process repeated with an image of the T5 re-entry; (c) the eight corners provide an estimate of the centering and rotation for launching an optimization procedure to align the images; a gray-scaled image shows the subtraction with false coloring in blue or red if the differences are greater than a threshold; (d) local alignment corrections are determined for each of 96 equal sections in this example; the inset shows an expanded view of the (x,y) pairs of correction shifts for each section; these values are in hundredths of a pixel; (e) the final subtraction including the corrections from (d); and (f) the subtraction of two entirely different scans of the stamp shown in (a) leaves only a faint ghost arising from small differences from sources such as scanning and interpolation.



## METHOD INVESTIGATION AND DEVELOPMENT

The first challenge in subtracting two high resolution stamp images is the alignment problem. Beginning with two similar sized stamps, a two-dimensional translation and a rotation are needed to align the two images. It is important to note that this alignment will be approximate, given the finer differences expected throughout the images.

Two approaches were evaluated for this “first-order” alignment of the images. One approach is a direct computational mapping of one to another, representing the stamp images as nearly-rectangular trapezoids. Another approach is a mapping consisting of three parameters,  $x$ ,  $y$ , and  $\theta$ , where  $x$  and  $y$  are horizontal and vertical translations, and  $\theta$  is a rotation. This second approach requires optimization and has the disadvantage of being computationally intensive. Both approaches were found to be useful in certain applications.

In the trapezoidal mapping approach, the accurate determination of the four corners of each stamp allows a parametric description, in which a grid varies proportionally along each edge. This provides a direct bilinear mapping from one image to the other. The new pixel coordinates from the mapping will not coincide with the existing pixels of the image being mapped into, but instead must be interpolated to the existing pixel positions. There are a number of interpolation routines to choose from; the widely-used bicubic interpolation (Keys, 1981) was used in this research. The quality of this trapezoidal mapping is very dependent on the accurate determination of the four corner positions, typically defined by the outer border of the design of most stamps. Close examination of a high resolution image<sup>3</sup> will raise an immediate concern because the printing is somewhat irregular along the stamp edges at high resolution, especially near the corners of stamp borders.

To circumvent this problem, all images are analyzed from the edges inward to locate the color transitions from unprinted to printed paper that define the borders of the stamp design. This search along the length of each edge creates an array of points that is least-squares fit to a straight line along each border of the design.<sup>4</sup> The intersections of these four lines then define the four virtual corners of the stamp. Figures 1(a) and 1(b) illustrate this process for the blue Bank Check Documentary revenue stamp of the U.S. First Issue. The four cross-hairs show the virtual corners for the bordered design of the stamp. The stamp in Figure 1(b) has a re-entry feature in which bottom edge features have been duplicated by the transfer roll in producing the printing plate.<sup>5</sup>

The first-order alignment by translation and rotation was optimized using the Nelder-Mead (“simplex”) method (Nelder and Mead, 1965). The optimization seeks the minimum of the sum of the absolute differences of all of the pixels. Optimization calculations used interpolation, but the method steps always started with raw image file data. Appendix A provides a detailed description of the calculations. Simplex optimization benefits greatly from good initial value estimates. The averages of the four virtual corners provide estimates for the image centers, and the difference between these positions gives initial estimates for the translations. The rotation angle,  $\theta$ , is estimated from the sets of slopes for the stamp borders. This approach has consistently

converged to a reasonable optimum mapping. Evidently, the high resolution images of stamps are sufficiently similar that this approach works very well.

Figure 1(c) shows the image differencing following this first-order alignment by simplex optimization. Images for this research are either 8-bit gray scale images, or 24-bit RGB color images consisting of 8-bit red, green, and blue values for each pixel. The 8-bit gray scale differences are colored red or blue if the absolute value of the difference in pixel values is greater than a threshold set to 100, red if the value from the second stamp was greater than the first, and vice versa with the blue color.<sup>6</sup> In this case, the manuscript cancels unique to the first stamp appear in blue, and the cancel unique to the second stamp appears in red. Note that the image subtraction in Figure 1(c) shows substantial red and blue coloration, much of which originates from imperfect alignment, size differences, distortions, digital noise, color differences, and scanner imperfection.

To improve subtraction results over the first-order difference shown in Figure 1(c), it is necessary to seek smaller, second-order corrections to adjust for local distortions. These can originate from a variety of sources and are not expected to be homogeneous over the image. To determine these “second-order” corrections, the images were divided into many sections, and the subtraction of each section was re-optimized using the Nelder-Mead process. The first-order alignment of Figure 1(c) launched this re-optimization. Figure 1(d) shows the small, second-order adjustments determined using 96 equal sections (12 rows x 8 columns). The  $x$  and  $y$  second-order adjustments for each section are in units of hundredths of a pixel, and a portion of the image is enlarged for view. The images have resolutions of 1200 dpi, so a value of 100 on this scale corresponds to 1 pixel of shift, or about 21  $\mu\text{m}$ . The sum of all of the shifts in the image in either direction is typically nearly zero because the first-order alignment process closely aligns the image centers.

As a result, the second-order corrections tend to increase from the center out to the edges with opposite signs. The range of the second order corrections in this example is 2.50 pixel (53  $\mu\text{m}$ ) in the horizontal direction and 1.34 pixel (28  $\mu\text{m}$ ) in the vertical direction. In the event that a large image feature, such as a dominant re-entry, causes an anomalous shift in the second-order corrections, parabolic fits of the  $x$  and  $y$  shifts in both directions can adjust the values. This is seldom required, and has only been necessary for image sections with strong re-entry content that can create an additional local alignment possibility.

For the third and final subtraction of the images, the second-order corrections are interpolated over the image sections to locally adjust to the first-order mapping. The simplex optimization is next applied to a quadratic Bézier correction curve (Forrest, 1972) to correct for average color differences. Figure 1(e) shows the subtraction using the first-order mapping, the second-order adjustments, and the color adjustment. This subtraction is significantly improved over Figure 1(c). The lighter color is evidence of much better alignment and more complete subtraction of the images from each other. The remaining color highlights the major differences between the stamps. The strong re-entry shows clearly in red at the bottom of the gray-scaled image difference, and more weakly along the left edge.

The 24-bit color images give very similar results,<sup>7</sup> with the re-entry features visible in the original dark blue of the stamp.

The 8-bit complement of the color difference in each channel does create some false coloring, but the color of the raw image file remains true where it is not subtracted, such as in the re-entry at the bottom of the stamp. Similarly, the manuscript ink colors are true to the original stamps where not coincidentally overlapping and subtracting from each other. While 24-bit color and 8-bit gray scale approaches give very similar results, the 8-bit images with thresholded, false coloring shown in Figures 1(c)-1(e) give more vivid results for most images with smaller file sizes and somewhat faster processing.

The residual background in Figure 1(e) has several contributing sources, including differences in pixilation, microscopic inking, scanner distortion, and paper distortion. It is therefore revealing to test the subtraction with other scans of the same stamp. To minimize the scanner's contribution to errors in differencing, the second scan of the stamp in Figure 1(a) was collected in a similar, but slightly different, position on the platen.<sup>8</sup> In this case, most of the image is eliminated as shown in Figure 1(f). With the scanning contribution minimized in this way, the average of the absolute values of the second-order corrections was less than 0.02 pixels with a standard deviation of less than 0.01 pixel. This corresponds to only  $0.4 \mu\text{m} \pm 0.2 \mu\text{m}$ . Thus, the fine details of the stamp, such as microscopic inking variation, are faithfully captured in both scans and subtracted away from each other.

The second-order corrections following trapezoidal mapping for the first-order alignment were found to be less centered than those obtained by optimizing alignment by translation

and rotation. It appears that the use of the full images' data and a centered initial estimate to start the simplex optimization provides a more consistently centered result. The local, second-order process is sufficiently robust to fully compensate for a less centered mapping, so the final subtractions are nearly identical for both first-order approaches. Because a well-centered first-order mapping provides some advantages for other analyses presented later in this article, the first-order alignment using simplex optimization is preferentially used for all of the data and discussion in the remainder of this article.

## EXAMPLES OF IMAGE DIFFERENCING

While Figure 1 shows results using image differencing to examine a major re-entry, Figure 2 contains examples with more minute re-entries along the left edge of the 1898 2½ cent U.S. Proprietary revenue stamp. This figure shows the left edges of a reference stamp (Ref) and several stamps with re-entries (A-D). The same detail peculiar to this plate position is evident on all four stamps as seen by the repeating pattern of the red highlights on the left edge and elsewhere on the stamps. It is important to use more than one reference stamp to correctly ascribe fine detail throughout the design to a particular plate position. Changing the reference stamp still reproduces these re-entry features; using a different reference stamp only changes fine detail in the image arising from microscopic differences in inking and a few larger flaws peculiar to the reference stamp.

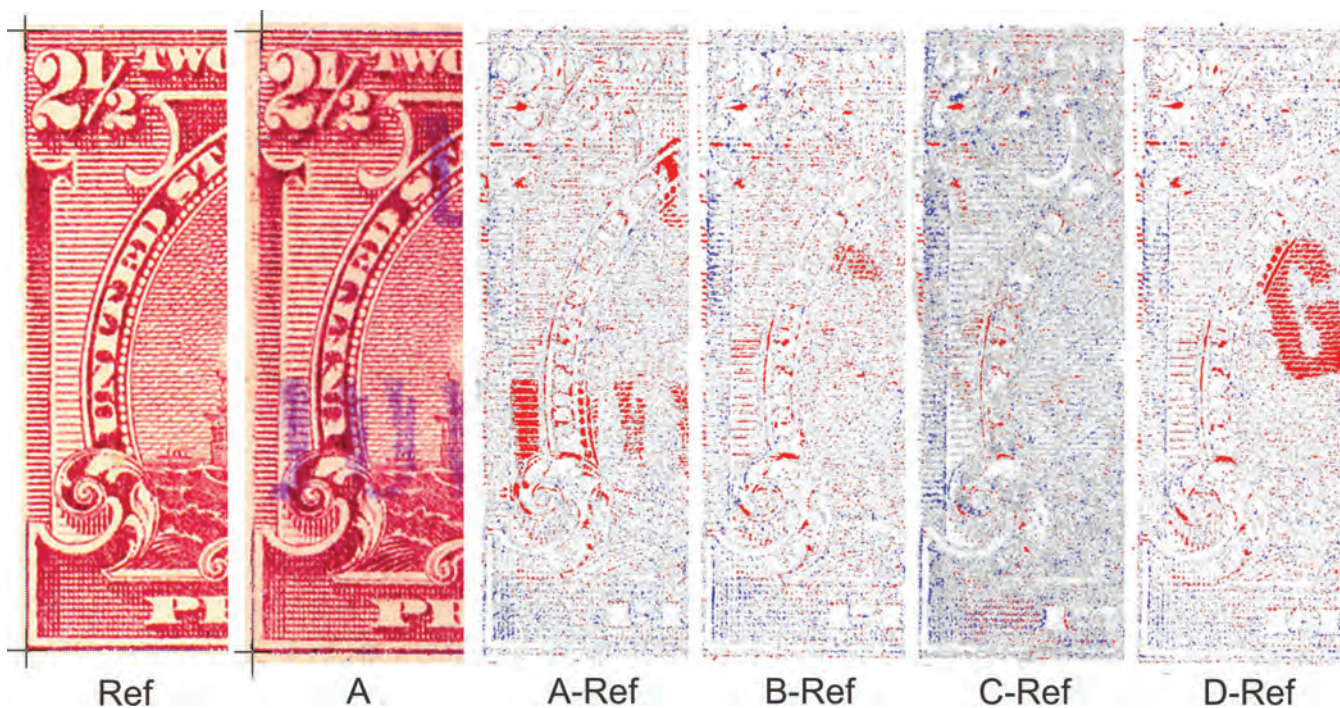

FIGURE 2. Image subtraction illustrated with four different examples, A-D, of a re-entry variety of the 2½ cent Proprietary revenue stamp of 1898. The left edges of the stamps are shown because the re-entries are most prominent along the left edge. The reference stamp (Ref) is at the far left and the re-entry 'A' is shown in color adjacent to it. The four differenced images in false-colored gray scale show matching re-entry patterns.





FIGURE 3. An example using subtraction to highlight poorly visible plate-crack detail on the First Issue 15 cent Inland Revenue Documentary stamp. Since the features to be enhanced are faint, 24-bit color images are used instead of thresholded, false color images with gray scale. Views of the multiple cracks and a fork in the crack are significantly enhanced by the subtraction. The crack traversing the hair in the portrait is visible on all three stamps after subtraction.

Figure 3 details three examples of the First Issue 15 cent Inland Revenue Documentary stamp with plate cracks near the top of the stamp after subtraction with reference stamp. While the plate cracks, indicated by arrows, are plainly visible near the top edge of the stamps in the original stamps, the subtraction makes the extension of the plate crack down into hair on the portrait visible on all three stamps. Only the middle stamp on the left shows this before the subtraction. The differencing also brings out poorly visible detail such as a fork in the cracks in the letter 'E.' In this example, 24-bit color image subtraction enhances the view of these faint features much better than thresholding, as in Figure 2, which can diminish the view of faint features.

A fourth example, Figure 4, shows image differencing with a group of lithographed stamps from Batum. The inking

of these stamps is very uneven, typical of some lithographed stamps. Figure 4(a) shows the genuine type B for Batum #1 (Ceresa, 1993). The numerals were added on different occasions, as shown by the subtraction of this stamp with the genuine type C in Figure 4(b). The extensive inking differences result in a large amount of color speckled throughout the image. Despite this, the subtraction aligns all of the stamp design extremely well, with the exception of the numerals. Close alignment is especially evident in the white spaces in the design. Figure 4(c) shows the differencing of a pair of Batum #1 forgeries, types I and II (Ceresa, 1993). The subtraction shows these forgeries to be somewhat similar, but with extensive small shifts in design throughout. These many shifts result in the large amount of excess blue color along the edges of white spaces, and also in features such as the larger "KOA" letters. Figure 4(d) shows





FIGURE 4. The differencing of images of genuine and forged stamps of early Batum. (a) shows the genuine type B for Batum #1. The subtraction of (a) with a genuine type C of the same stamp results in image (b). There is substantial noise from uneven inking in the production of the lithographs, but the alignment is very good apart from the differing numeral entries for the two types. The subtraction of the types I and II forgeries produces (c) which has differences everywhere. The subtraction of the type II forgery with the genuine type B in (a) produces the image in (d) which has large differences throughout.



a more severe comparison, the subtraction of the Batum #1 genuine type B with the type II forgery. The many solid areas of color indicate major differences throughout, such as the dissimilar branching of the aloe trees.

These examples demonstrate the power of this new image subtracting method to compensate for a variety of distortions and enhance the detailed view of fine differences between stamps. The results with the multiple examples of re-entries show strong consistency even though the stamps have slightly different sizes. The plate-crack examples show the ability to more clearly see faint features in images of poorly printed stamps. The ability to make global comparisons of the differences in variably inked stamps is well demonstrated by the Batum #1 lithographed stamps. Despite a large amount of speckle created by inking differences, the similarities and differences of the overall designs are clearly evident and are visualized in their entirety. The large differences between the genuine and forged Batum #1 stamps that extend over their entirety demonstrate the robustness of the method in its ability to distinguish differences between images.

## FURTHER STUDY OF THE SECOND-ORDER CORRECTIONS

The preceding figures illustrate that this new, second-order correction process provides a greatly improved comparison of two stamp images to highlight detailed differences. This section of the article explores what these second-order corrections can tell us about ordinary stamps without significant flaws. Do the small, second-order corrections reveal any general information about regular stamps? Or are they only inconsistencies unique to each pair of stamps? The second option would seem more likely because significant distortions occur due to differences in paper shrinkage and scanner variability.

The second order corrections consist of a large grid of x and y corrections, as shown in Figure 1(d). Consequently, the study of a large number of comparisons between multiple stamps involves a data intensive investigation of many numerical grids with results that can be difficult to visualize. For this reason, we will now switch from illustrations of stamps to a graphical visualization of grids of these second order corrections. We will use shaded contour plots for this purpose. These are most familiar from their use in topographical maps. In these contour mappings, the lowest correction value is assigned the color black and the highest correction value is given the color white. The contours represent steps in these values in a table ranging between the two extremes and are shaded accordingly. A medium gray shade represents the middle of the range of values in the grid.

Every set of second-order corrections results in two different contour plots, one for the x values and one for the y values. The physical meaning is a simple one – the contours show the relative movement of each area of the stamp required for the fine alignment of the images. For the x contour plots, dark shades have a small shift to the left, while light shades have a small shift to the right. For the y contour plots, dark shades correspond to upward movement, while light shades show downward movement. Since the range of second-order

corrections is 1-3 pixels, the contour plots show ranges of movement of about 20-60  $\mu\text{m}$ .

How much image variability is due to the scanner, and what can be done to limit this variability? The dimensional accuracy of the scanner used in this research was measured to be better than 0.01% in the horizontal direction (Mustacich, 2014), a factor of approximately 20x better than the vertical direction. This is thought to be a consequence of the more complex mechanics of vertical scanning, which involves gears, belts, and backlash issues, compared to the horizontal scan direction, which is more dependent on just the optics and stability to displacement or to wobble (Poliakow et al., 2007).

The spatial variability of the Canon 9000F flatbed scanner was investigated by scanning images of the same stamp in a variety of locations on the platen and then using subtraction to monitor changes in the second-order corrections. Not surprisingly, changing platen positions caused large variations in the second-order corrections. However, if nearly the same platen position was used, manually repositioning the stamp to ensure a non-identical scan, then the second-order corrections remained relatively constant. Importantly, using nearly the same platen position on the scanner also gives consistent second-order corrections in the subtraction of different stamps from each other.

A scanning protocol was therefore established to maintain repeatability of the second-order corrections. In this protocol a paper mask on the platen guided the placement of the stamps to achieve nearly the same position for all scans. This mask consisted of an 8.5 x 11-inch sheet of cardstock with four rectangular holes for viewing and positioning the edges of the stamp underneath the cardstock. The cardstock registers to the upper right corner of the platen; Figure 5 shows a photo of the corner stamp of a block positioned using the mask. The perforations of three edges of the corner stamp are lined up just outside the edges of the center area of the mask.

Testing deliberate placement variation with this mask showed that 1.5 mm misalignments had very little effect on the second-order corrections. Less misalignment than this is easily

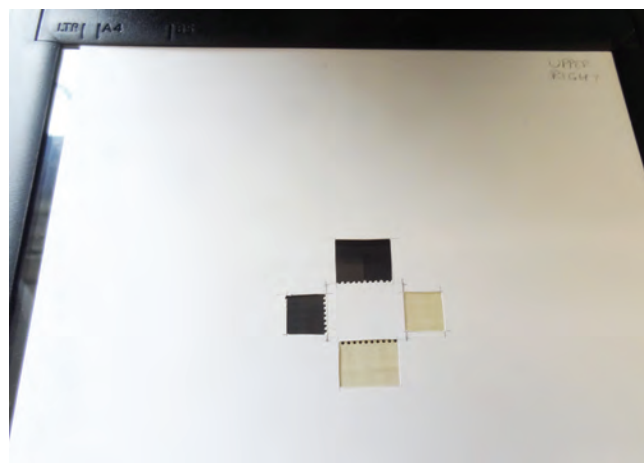

FIGURE 5. Mask on scanner for aligning stamps for repeated use of the same position on the platen.

achieved with the mask. The standard deviation of the absolute values of the differences in second-order corrections for the 96 image sections are less than 0.03 pixels over this 3 mm range of horizontal alignments. At 1200 dpi a pixel corresponds to  $\sim 21 \mu\text{m}$ , so the deviation is less than  $1 \mu\text{m}$  using this mask. The second-order corrections show very small gradients, which are approximately uniform in a single direction, and these gradients appear to vary with platen position. This suggests that these small gradients may be systematic distortion in the scanner. All images in the remainder of this article were obtained by scanning with this mask to minimize contribution to the second-order corrections by the scanner.

Image manipulations in pre-processing or in the subtraction calculations are also a potential source of error and increased noise. This was demonstrated by applying a sequence of three small rotations of less than 1 degree, chosen so that the sum of the three unequal rotations was a zero rotation, and then comparing the subtractions of the resulting image and the starting image with a reference image. The series of rotations introduced increases of 10% or more to the sum of the pixel differences between the images in the optimized subtractions. For this reason, image pre-processing steps that involve interpolation such as resizing or rotation were avoided.

Interpolation is used only for computational purposes in the optimizations and for visualization of the final subtraction result. First-order, second-order, and Bézier color corrections are accumulated and applied in aggregate to the raw image files as described in Appendix A. In other words, the raw image files are never modified.

Avoiding interpolative pre-processing and using the scanning mask protocol, Figure 6 shows the subtraction of a pair of plate blocks, stamp by stamp, of the same plate position.<sup>9</sup>

This block was a lower right (LR) plate #26003 of the  $\frac{1}{2}$  cent 1953 dry-printed Franklin stamp. The subtraction of the two blocks reveals similar and approximately uniform large gradients in both the horizontal and vertical directions. For the x (horizontal) correction contours in the center block, the dark shades show a shift to the left and the white shades a shift to the right. This shows a relative horizontal expansion of all of the stamps in one block relative to the other block of stamps. The y corrections show the same relative expansion in the vertical direction. The range of these second-order corrections is 1-2 pixels, or approximately  $20\text{-}40 \mu\text{m}$ . This result shows a significant size difference between the plate blocks. If the blocks were identical, the contour images would be uniformly mid-gray. The overall uniformity of the gradients would be consistent with a difference in post-printing paper shrinkage between the sheets. It should be noted the dry printing process for these stamps still involves wetting to about 5-10% additional water by weight (Faries, 1982), so the paper expansion can be substantial.

Comparing wet-printed stamps of the same issue using LR #25263 plate position blocks provides a similar result, but with somewhat less uniform gradients of 2-3 pixels, or approximately  $40\text{-}60 \mu\text{m}$  of distortion difference. Wet printing involves typical water uptake of 15-30% by the paper (Faries, 1982), and can be subject to greater shrinkage after printing. These results suggest that subtraction of the same plate positions simply exhibit large differences from paper shrinkage after printing. This is consistent with the differences of several pixels in comparing the stamp design sizes using the four virtual corners. In fact, before paper shrinkage was fully appreciated in philately, there was an erroneous belief that in some cases stamps were printed from more than one set of plates, or

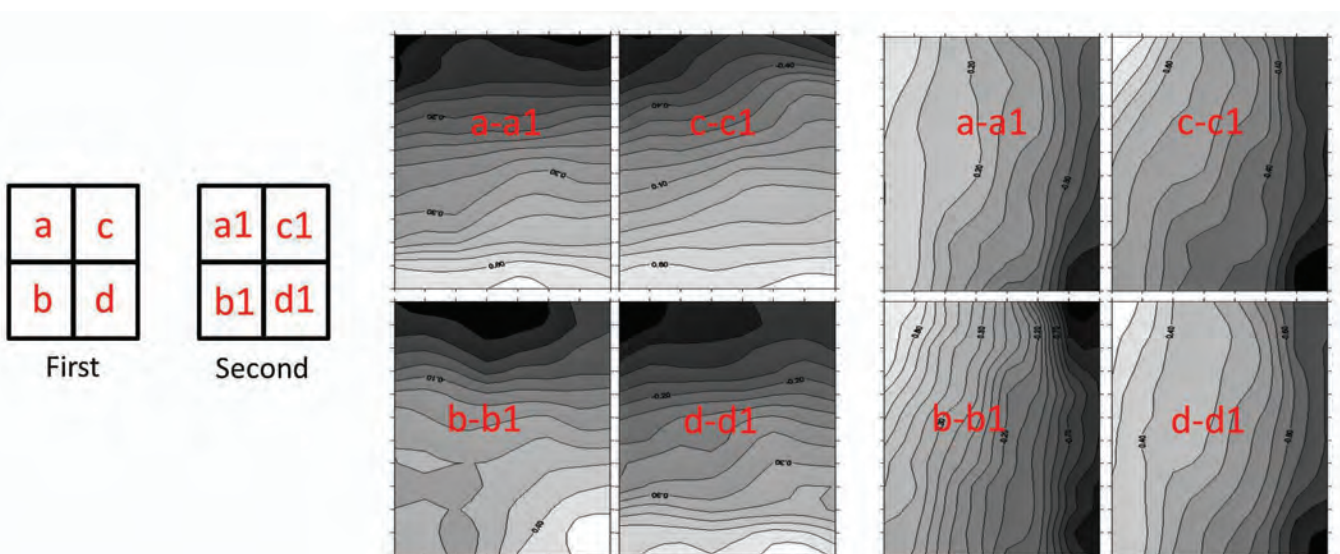

FIGURE 6. Image differencing of two same-number (#26003), same-plate position (LR) plate blocks of the  $\frac{1}{2}$  cent 1953 dry-printed Franklin stamp. Large and relatively uniform gradients in the x component displayed as shaded contour plots are shown in the center, and for the y component at the right. These large gradients are the expected result of large differences in shrinkage between the sheets following printing.

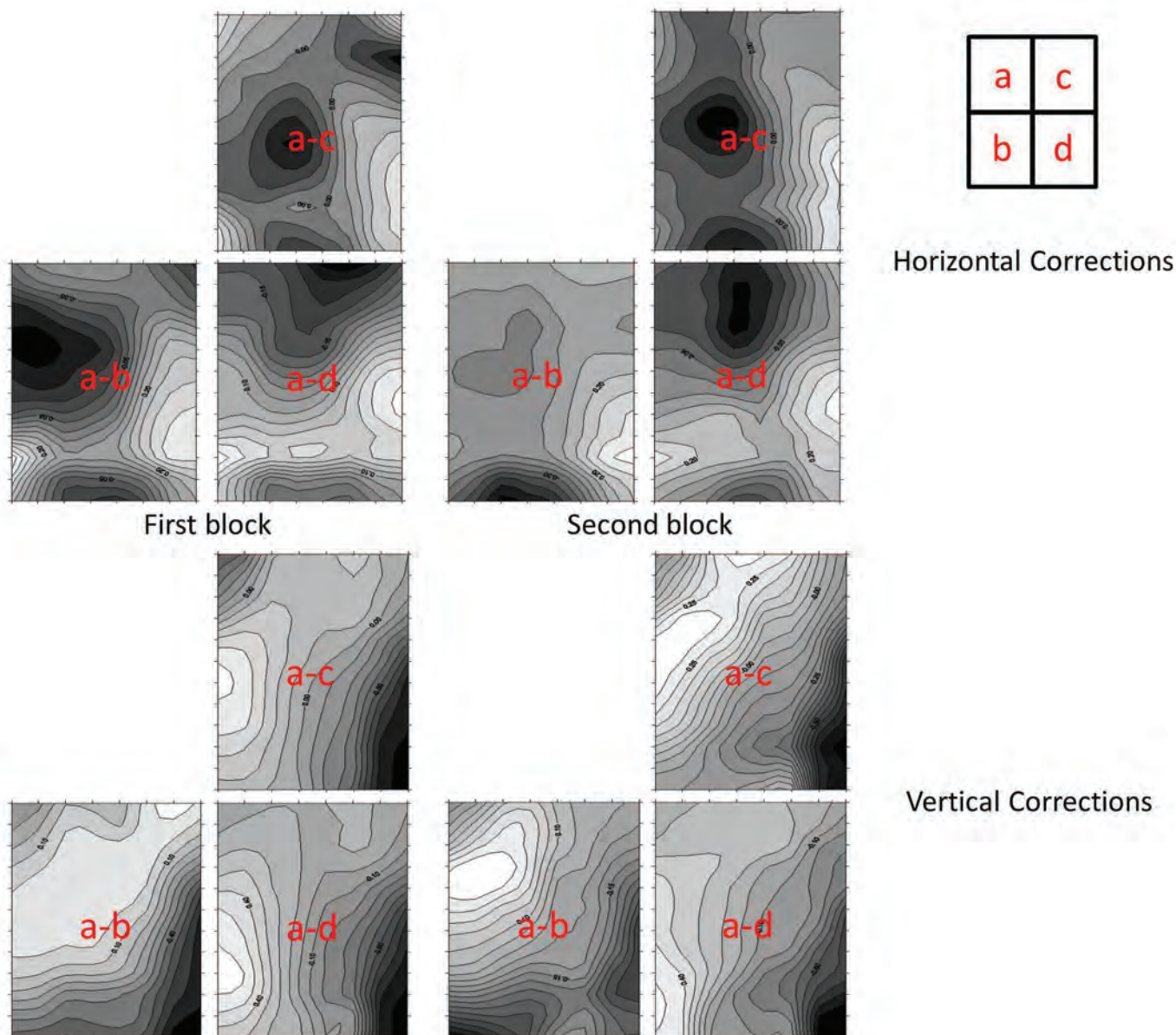

FIGURE 7. Intra-plate differencing of the stamps in same plate block, in this case subtracting all positions from stamp a. Repeating with a second block of the same plate number and position gave very similar results suggesting that intra-plate comparisons may be relatively independent of the post-printing shrinkage.

plates were made from dies of different sizes (Williams and Williams, 1971).

Measurements of paper expansion and shrinkage of a lower right #25981 block of the ½ cent 1953 Franklin stamp showed that the stamp can expand about 1% or more in both directions when wet.<sup>10</sup> Water uptake was measured with an analytical balance, and size was measured by the virtual corner positions in the differencing software. These changes amount to 200-300 μm. It becomes obvious that differences in paper shrinkage, comparing any two sheets of the same stamp, contribute significantly to inconsistencies in the images under microanalysis.

In order to avoid this shrinkage-caused distortion, stamps were next compared within a single sheet. Since the entire sheet would have undergone a relatively uniform wetting and shrinking, we hoped to find more image consistency. To explore this possibility, we selected one stamp in each of two blocks and subtracted from those the images of the other three stamps in the block. Figure 7 shows an example of this intra-sheet differencing using a pair of LR #26003 ½ cent 1953 Franklin plate blocks. The stamp positions in the block are labeled *a* to *d*, and the images of stamps *b* through *d* were subtracted from the image of *a* resulting in a set of three contour plots for the second-order corrections for both blocks.



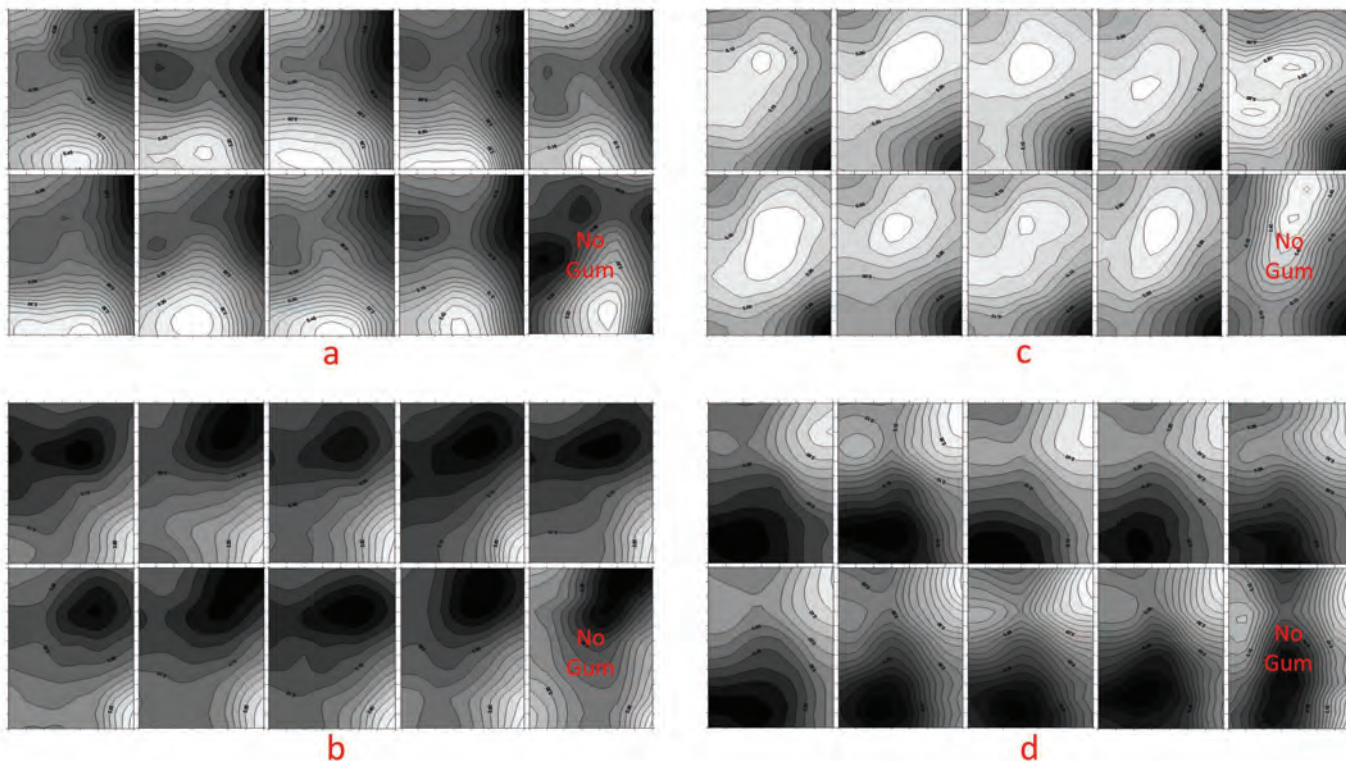

FIGURE 8. Relative patterns calculated for all four positions comparing the results from 10 same plate-number, same plate-position plate blocks of the LR #25981 ½ cent dry-printed 1953 Franklin stamps. All of the relative patterns for each position are nearly the same. One block was without gum and gave slightly different results. These very reproducible patterns appear to be plate differences in the impressions made by the transfer roll.

Comparing the side-by-side results for the two blocks shows a remarkable similarity for the same position differences. For example, comparing the two “a-c” contour plots in the top of Figure 7 shows that both have small values (black) left of center and at the middle of the bottom edge. Both have large values (white) at the bottom right side, and larger values also on the corners on the left side. The upper right corners in the left plot have a small region of black and white near each other, while the right plot has an average value (a neutral gray). The gross overall features are well repeated in comparing the contour plots of the two blocks, although the upper “a-b” plot for the second block has a shallower low value near the center. This general result can be repeated with different choices of stamps in the block to result in entirely different contour patterns specific to each position that are very similar between the two blocks.

Each of the four sets of three contour plots in Figure 7 can be averaged together to estimate an inherent pattern for the stamp in the *a* position. This pattern for the *a* position represents how the second-order corrections for stamp *a* compare with the average of the corrections for the other stamps. With four stamps six image subtractions are possible, and different combinations of these subtractions provide estimates for how the other three stamps differ from the average. Appendix A describes the combinations used to create these estimates.

Using more stamps provides more averaging and should make these estimates more reliable. Nonetheless, using just the four stamps of each block in Figure 7 gives very similar patterns when comparing the two blocks.

The repeatability of this result was explored further with a set of ten same plate-position blocks of LR #25981 ½ cent dry-printed 1953 Franklin stamps. Combinations of intra-block image differences were used to estimate the relative patterns at each position. Figure 8 shows together the ten results for the horizontal component of each position for direct comparison. The similarities of the distortion patterns are extraordinary, although the tenth block was without gum and is slightly different from the others. In comparing all of the *a* position results, for example, the low values (black) are strongest in the upper right and spread horizontally across the plots, while the large values (white) are bottom and top. The results are similarly consistent in comparing the vertical components for these relative patterns. These patterns are much larger and very different from the micron size and relatively uniform gradients produced by the scanner, and are intermediate in size to the large gradients observed with direct inter-sheet comparisons as in Figure 6.

These findings result in two decisive observations. First, each stamp within a plate block reveals an individual profile of second-order corrections as illustrated by the four distinct patterns in Figure 8. Secondly, this profile is remarkably similar





FIGURE 9. Overlapping blocks for comparing the calculations of the relative distortion patterns using different numbers and choices of stamps.

for stamps originating from the same position on the printing plate. This finding suggests that the printing plate itself is responsible for the intra-sheet differences that are reproducible from sheet to sheet.

These slight “quirks” between the impressions on a plate likely occurred in the manufacture of the plates. Each design impression on a soft steel printing plate was made by “rocking in” the design using a hardened-steel roller, frequently called the “transfer roll,” under high pressure. This process, called siderography, is manual, and is consequently variable. The periodic application of high pressure as the design is “rocked in” by the transfer roll results in a plastic flow of the soft steel in the underlying plate that is displaced near its surface. If the plate is moved too quickly under the roller, or if the pressure of the roller is increased too quickly, this can result in a wave of steel in front of the roller that elongates the impression and distorts the image. This is known as a transfer shift (Granzow, 2012). Under careful operation these large transfer shifts should not occur, but distortions are expected because metal must be displaced according to just how each transfer is manually rocked in. The consistency in Figure 8 across all of these different

printings from the same plate positions suggests that we are directly observing the intrinsic relative differences between the plate impressions.

## RELATIVE PLATE DISTORTION PATTERNS

The results in Figure 8 demonstrate that combinations of image subtractions can estimate how each plate position differs from the average impression on the plate. An important question is: how many stamp image differences are needed for a good representation of the average impression? The following examples describe a series of comparisons in which the relative patterns are recalculated with larger numbers of stamps and with alternative choices of these stamps. In some cases, these calculations were replicated with the same positions on a second sheet of the same plate number to check repeatability. Figure 9 shows the general scheme for these comparisons in which a block of four outlined in red is selected, and a variety of larger overlapping blocks are independently used to recalculate these relative distortion patterns using additional stamps.

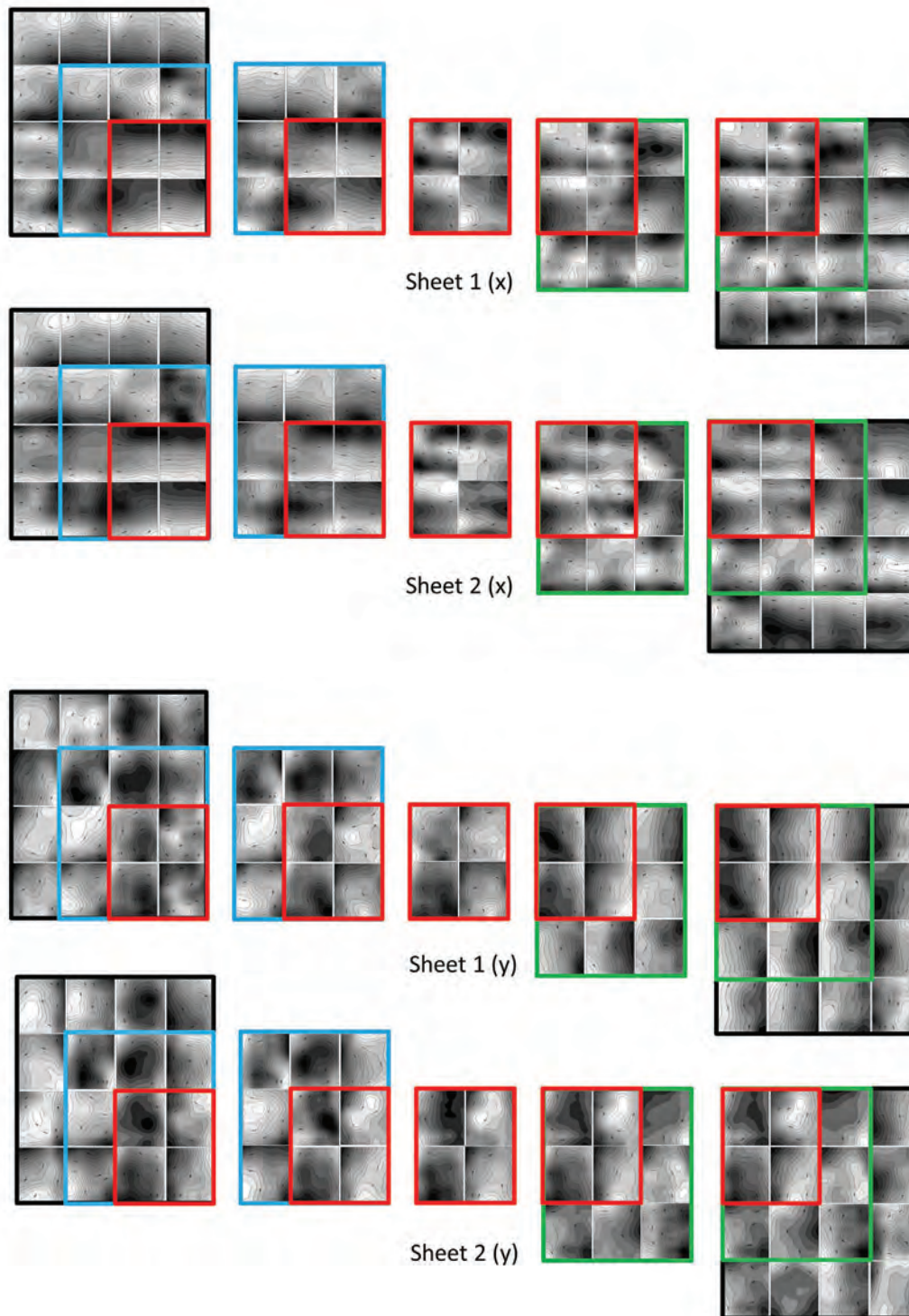

FIGURE 10. Relative distortion patterns calculated for the different blocks shown in Figure 9 applied to two of the same plate number sheets. The x contours are for the horizontal components of the second-order corrections, and the y contours are for the vertical components. Increasing the number of stamps used in the differencing from 3 to 8 can shift the patterns, but increasing the number of stamps from 8 to 15 shows little further effect. While very similar results are obtained with the second sheet, it is clear that the results vary according to the specific stamps selected for the differencing calculations.



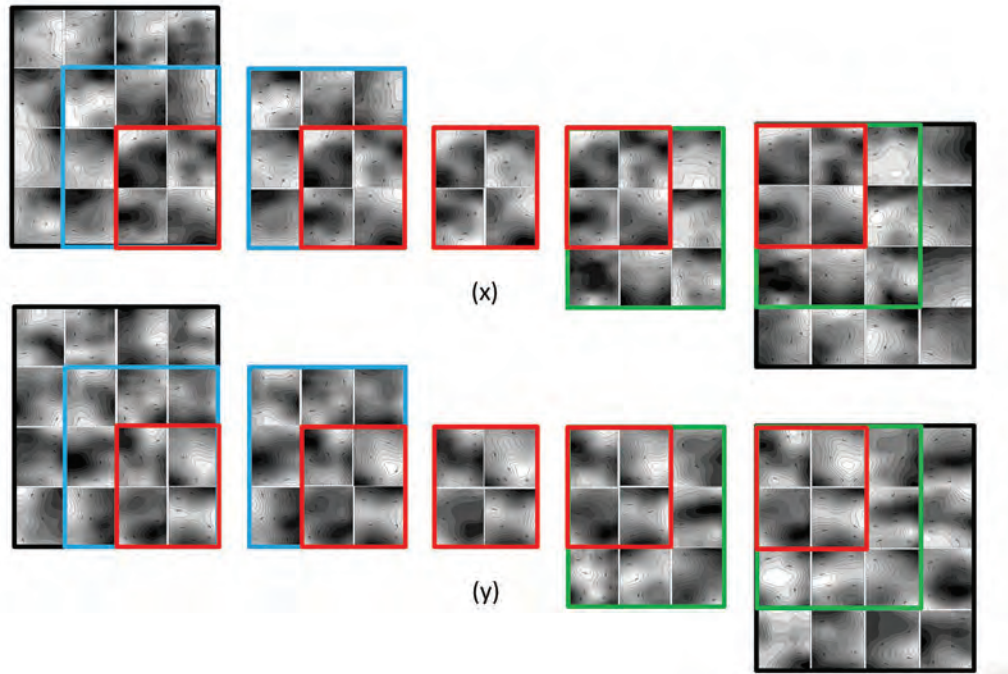

FIGURE 11. Similar analysis of overlapping blocks in a multiple of the 1/8 cent Proprietary revenue of 1898. The different choices of stamps right and left of center have coincidentally similar results.

Figure 10 shows the relative patterns computed for the five different overlapping blocks in the sheet illustrated in Figure 9, the identical computations also being done on a second sheet. Figure 10 shows that the contours for the relative distortion patterns change as additional stamps are included in the computation, especially in going from a block of four stamps to a block of nine stamps. Comparing the patterns for the block of four stamps bordered in red, it is clear that the changes vary according to the different stamps that are sampled. Examining the upper right stamp as an example, the contour plots are similar between the left pairs of 16- and 9-stamp blocks for each row in Figure 10. The contour patterns are also similar between the 16- and 9-stamp blocks on the right. Comparing the patterns on the left with the patterns on the right, however, shows both have some similarities and differences. Comparing sheet 1 and sheet 2 for the x or y components shows general similarity. In many cases the changes are large in comparing the 9-stamp blocks with the 4-stamp blocks.

It is not surprising that the relative distortion patterns should shift in going from combinations using only 3 differences (a block of 4 stamps) to 8 differences (a block of 9 stamps) since 3 differences may poorly represent the average impression on the plate. It is clear that a large number of image differences may be required to represent the average plate impression, and that the differences observed between sheets may still represent some residual inhomogeneity.

Other sheets of stamps were analyzed using the same series of overlapping blocks to compare patterns. The wet printed plate #25263 1/2 cent Franklin postage stamp of 1953

gave similar and matching results with two sheets of stamps. Similar results were also observed in the study of a single sheet of plate #21149 experimental electric-eye perforated 2 cent Washington stamps of 1935. Again, the choice of additional stamps used in the calculations affects the patterns.

A similar analysis of overlapping blocks in a 6x6 multiple of the 1/8 cent proprietary U.S. revenue of 1898 is shown in Figure 11. The plate number is unknown. Interestingly, the results are more similar to each other than in the previous examples. Again comparing the upper right stamp in the red block of four, this contour pattern remains nearly the same across the sets of 5 blocks. It appears in this example that the various groups of stamps happen to have collectively similar characteristics, resulting in more consistency of the computational results.

Figure 12 shows the same analysis of a 12x10 multiple of the perforated 1 cent Proprietary U.S. revenue stamp of 1862. Each stamp on the sheet was manuscript pre-canceled using fine letters with black pen near the center, but the sheet was unused and has original gum. The results are shown in Figure 12. Similar to the previous example of the 1898 revenue stamps, the results calculated with different groups of stamps give mostly similar comparison results. An unusual feature of this early sheet of stamps is the spotted distortion patterns. This does not appear to be caused by the manuscript cancels because these are near the centers of the stamps. Also, the manuscript cancels are thin script in black, effectively null data which little affect the calculation of the second order corrections; the presence of the cancel does not appear to cause misalignments of sections in the computation of the second-order corrections.



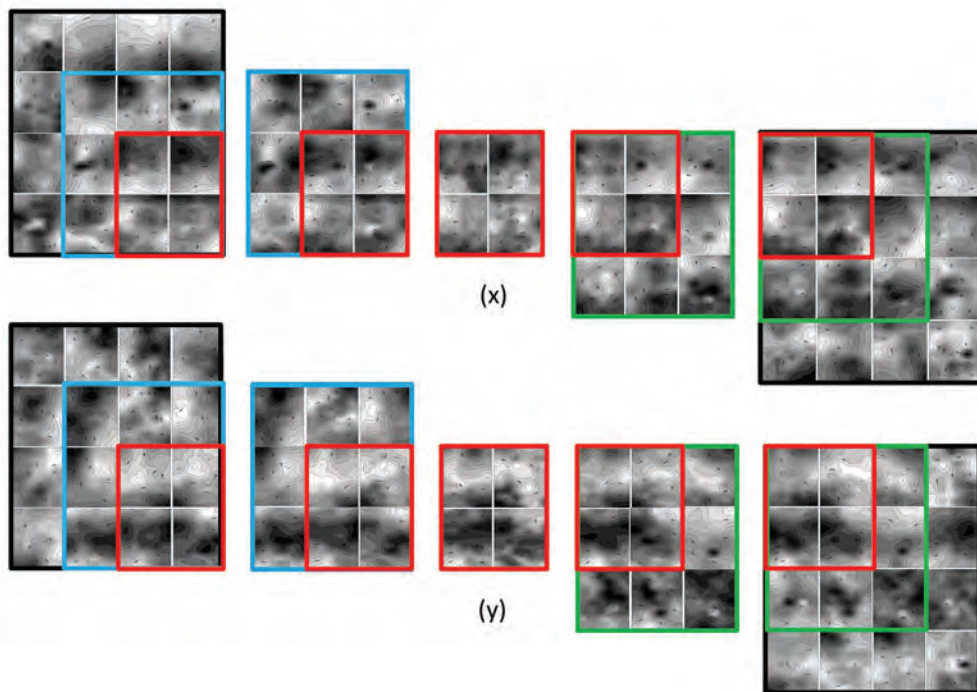

FIGURE 12. Comparison of overlapping block results for a large multiple of the 1 cent Proprietary revenue stamp of the 1862 First Issue. This example gives similar results to the other comparisons with overlapping blocks, but differs in the more irregular and spotted contours. The cause of this irregularity is not known.

A possible cause for the unusual distortion patterns in Figure 12 could be the situation in which these plates were manufactured. The First Issue revenue plates were made in the early days of siderography, and the contractor, Butler & Carpenter was under great strain to produce revenue stamps very quickly for the U.S. government. While the 1 cent and 2 cent Proprietary stamps were actually the first two stamps printed and distributed by Butler & Carpenter in September 1862 (Toppan, Deats, and Holland, 1899), the production date of the tested block is not known.

The fact that it was pre-canceled (initials only, no date) and never used presents the possibility that it was a remainder late in the period of taxation. Given the struggle of the contractor to produce plates during the First Issue, it might be tempting to attribute the more irregular distortion patterns in Figure 12 to hastily produced plates, but this could also reflect a materials problem with certain early plates in the Perkins Bacon process.<sup>11</sup> More testing is needed to determine if this feature is found in other of the First Issue revenues, or whether these more irregular patterns are peculiar to this large multiple. There is gum disturbance on some of the stamps, but the areas of these disturbances do not appear to correlate with the irregularities of the contour patterns.

## CONCLUSIONS

This research demonstrates the ability to directly compare one high resolution image of a stamp with another, pixel-for-

pixel. This is done by determining an array of local, second-order adjustments to correct for distortions between the images. The principal distortion between sheets is paper shrinkage, and this was confirmed to be a large effect by direction measurements of expansion and shrinkage by wetting and drying, at least for intaglio-printed stamps. The corrected subtractions show fine detail of the differences over the full extent of the printed stamps, and can be used to compare plate differences due to re-entries, plate flaws, and forgery. It is possible to reveal faint features that are very poorly visible in the original stamps as demonstrated with the example of the plate cracks.

The second-order corrections themselves reveal relative distortion patterns between different impressions on the plate when computed using stamp images from the same sheet. This intra-sheet comparison compensates for gross paper shrinkage after printing. The distortion pattern for each stamp impression relative to the average impression on the plate can be estimated using combinations of these intra-plate image subtractions. These patterns appear very repeatable if stamps from the same position are used.

Because using a large number of stamp-image differences from a sheet can give the most reliable estimate of the average impression on the plate, there is the possibility that an idealized, average plate impression can be reliably determined by using a sufficient number of stamps. This could provide a synthetic representation of the particular transfer roll relief that was used to create the plate impressions. With some scaling factor for sheet shrinkage determined from the size of a stamp,

it is possible that this image of the average impression could be directly differenced with any single stamp for characterization purposes. If successful, the resulting correction patterns could have value for determining possible plate positions based on the correlation of these patterns with different plate positions.

### APPENDIX A. DESCRIPTION OF THE IMAGE DIFFERENCING CALCULATIONS

The first order alignment of the images is accomplished with a correction,  $A(x, y)$ , applied to the first image  $I_1(x, y)$  before differencing it with the second image  $I_2(x, y)$ . The function  $A(x, y) = T(x, y) + R(\theta)$ , where  $T(x, y)$  is a translation operation  $T(x, y) = (x + x_0, y + y_0)$ , and  $R(\theta)$  is the rotation by angle  $\theta$

$$R(\theta) = \begin{bmatrix} \cos \theta & -\sin \theta \\ \sin \theta & \cos \theta \end{bmatrix}$$

and  $x_0, y_0$ , and  $\theta$  are initially estimated from the differences of the stamp center coordinates and the slopes of the stamp boundary lines.

The new calculated coordinates for the first image's pixels from the correction  $A(x, y)$  are interpolated into the second image's coordinates using bicubic interpolation (Keys, 1981). For one dimension, the interpolation  $p(t)$  between points  $a_0$  and  $a_1$  using a linear factor  $t$  ranging from 0 to 1 is:

$$p(t) = \frac{1}{6} [1 \ t \ t^2 \ t^3] \begin{bmatrix} 0 & 2 & 0 & 0 \\ -1 & 0 & 1 & 0 \\ 2 & -5 & 4 & -1 \\ -1 & 3 & -3 & 1 \end{bmatrix} \begin{bmatrix} a_{-1} \\ a_0 \\ a_1 \\ a_2 \end{bmatrix}$$

For two dimensions first applied once in  $x$  and again in  $y$  using factors  $t_x$  and  $t_y$ , where each ranges between 0 and 1, the bicubic interpolation is expressed as:

$$\begin{aligned} b_{-1} &= p(t_x, a_{(-1, -1)}, a_{(0, -1)}, a_{(1, -1)}, a_{(2, -1)}) \\ b_0 &= p(t_x, a_{(-1, 0)}, a_{(0, 0)}, a_{(1, 0)}, a_{(2, 0)}) \\ b_2 &= p(t_x, a_{(-1, 2)}, a_{(0, 2)}, a_{(1, 2)}, a_{(2, 2)}) \\ p(x, y) &= p(t_y, b_{-1}, b_0, b_1, b_2) \end{aligned}$$

The Nelder-Mead simplex optimization minimizes the difference function  $F$  for each dimension of color

$$F = \sum_{x=0}^n \sum_{y=0}^m |I_2(x, y) - A(x, y)I_1(x, y)|$$

where  $n$  and  $m$  are the lesser of the coordinate ranges for images  $I_1$  and  $I_2$ . In the case of 8-bit gray scale images, there is just a single dimension of color, but for 24-bit RGB color, the difference function to minimize is the sum of the above  $F$  expressions for each of the three colors.

The correction function  $A(x, y)$  expands with the inclusion of the second-order corrections to  $A(x, y) = T(x, y) + R(\theta) + S(x, y)$ , where  $S(x, y)$  is the interpolation over the grid of the local

sectional corrections. Each local section is re-optimized by the simplex method beginning with the data already transformed with the first order  $T+R$  corrections. The local re-optimization is done in 2 parameters with adjustments to  $x$  and  $y$  only. Using the center coordinates of each section,  $S(x, y)$  is determined using bilinear interpolation between the center coordinates:

$$S(x, y) = (P_x(i, j) + \Delta x(P_x(i, j+1) - P_x(i, j)) + \Delta y(P_x(i+1, j) - P_x(i+1, j+1) + P_x(i+1, j) - P_x(i, j))/2, P_y(i, j) + \Delta x(P_y(i, j+1) - P_y(i, j)) + \Delta y(P_y(i+1, j) - P_y(i+1, j+1) + P_y(i+1, j) - P_y(i, j))/2)$$

Where  $P_x$  and  $P_y$  are the second-order  $x$  and  $y$  corrections found for each section in the  $i, j$  array of sections, and  $\Delta x$  and  $\Delta y$  are the fractional distances (0-1) between section centers. For  $x$  or  $y$  values having coordinates outside the ranges of the section centers, the local section's correction is used.

The color correction,  $C(x, y)$ , introduces an additional term to the function  $F$  for minimization:

$$F = \sum_{x=0}^n \sum_{y=0}^m |I_2(x, y) - C(x, y)A(x, y)I_1(x, y)|$$

where  $C(x, y)$  is a correction determined by a quadratic Bézier curve of the form mapping the range of byte values 0-255 from one axis to the other.  $P_0$  and  $P_2$  are constrained to points (0,0) and (255,255), while simplex optimization is used to determine the coordinates of the intermediate Bézier curve point  $P_1(x, y)$  so that the curve parametrically maps  $x$  values to  $y$  values which represent a color correction to the  $x$  values. The Bézier curve can be written

$$B(t) = (1 - t)[(1 - t)P_0 + tP_1] + t[(1 - t)P_1 + tP_2]$$

The trapezoidal mapping that can be used as an alternative to the three-parameter optimization of translation and rotation is simply a bilinear mapping between two trapezoids. This computation is fast since it does not rely on optimization, but the centering of the mapping is more dependent on the quality of the virtual corner calculations than on the overall alignment of the image data. The second-order corrections are sufficiently robust to provide equivalent overall subtraction results, but are not typically as well centered as the results with the three-parameter optimization for applications where combinations of the second order corrections are of interest for comparing distortion patterns.

The differencing of images can be used to estimate the distortion pattern of an individual stamp relative to the average pattern of a group of other stamps. For example, there are six possible differences,  $A$  through  $F$ , that can be taken with a block of four stamps labeled  $a$  to  $d$ . These are  $A = a - b$ ,  $B = a - c$ ,  $C = a - d$ ,  $D = b - c$ ,  $E = b - d$ , and  $F = c - d$ .  $A$  through  $F$  can each be viewed as a pair of matrices of second-order corrections, one for the  $x$  corrections and one for the  $y$  corrections. In effect, this calculation is just linear combinations of matrices of these second order corrections. The average of the first three differences listed above is  $(A + B + C)/3 = a + (-b - c - d)/3$ . If the relative patterns for  $b, c$ , and  $d$  are sufficiently dissimilar, then the second term  $(-b - c - d)/3$  can be small enough

to ignore as an approximation. Then,  $a \approx (A + B + C)/3$ . Other linear combinations of the image differences similarly provide estimates for the other stamps' relative patterns. For  $n$  stamps, there are  $n(n - 1)/2$  different possible combinations, and these can be represented by an  $n$  by  $n-1$  matrix in which the different combinations are first entered to the upper right triangle of the matrix. These entries are then mirrored about the diagonal to a lower left triangle with a change of sign to fill the matrix. The mirrored entries are bolded in the example below to emphasize this symmetry. The different linear combinations for the estimated relative patterns are averages of the horizontal rows in the matrix. This approach was used to compute the more complicated linear combinations for the general case of  $n$  different stamps. The linear combinations for the approximate relative patterns for the example block of 4 stamps is then:

A	B	C	$a \approx (A + B + C)/3$
-A	D	E	$b \approx (-A + D + E)/3$
-B	<b>-D</b>	F	$c \approx (-B - D + F)/3$
-C	<b>-E</b>	<b>-F</b>	$d \approx (-C - E - F)/3$

The sets of equations are not linearly independent and are therefore reduced to approximations.

## NOTES

1. Example software includes Photoshop (Adobe Systems Inc., San Jose, CA) and retroReveal (University of Utah J. Willard Marriott Library, Salt Lake City, UT).
2. Stamp Compare (<http://www.photogrammetry.com.au/stamps/>).
3. All images in this article were collected at 1200 dpi using a Canon 9000F scanner with the unsharp mask and high contrast settings active. These settings provided significantly sharper image differencing results.
4. Please note that this process also applies to most stamps with irregular borders, as shown in the example in Figure 1.
5. See illustration accompanying Scott No. R5.
6. It is less strain on the eyes to view the byte complement of the subtraction. While nearly equal pixel values would result in near zero differences, i.e. shades of black, for single byte color values it is preferable to view 255-S where S is the absolute value of the difference of the pixel values. This provides a white background when equal pixels are subtracted from each other, with increasing differences in the pixel values resulting in darker colors.
7. With the color images, the optimization minimizes the sum of the absolute values of the differences for each of the color channels. Also, prior to the final subtraction, each of the three image colors is independently optimized with a quadratic Bézier mapping, just as in the one-dimensional color case of the 8-bit gray scale image subtraction.
8. Scanning results can vary significantly over the area of the platen. Repeated use of the same location within a few mm minimized this variation. A protocol using a mask, described in

a later section of this article, minimized this variation. All scans described in this article follow this scanning protocol.

9. All stamps used in this study of the reproducibility of second-order corrections were mint, never-hinged stamps unless otherwise described.

10. All sheets and plate blocks were stored in identical air and relatively constant ambient humidity. The changes in ambient humidity are not believed to be large enough to result in significant differences in the scans.

11. The manufacture of printing plates for early postage stamps was during a time of evolving materials technology, especially for the reliable case-hardening of steel after the design transfers were made to soft steel. Changes were being made to the steel materials for improved hardening to reduce wear, and to reduce plate cracking under stress (Granzow, 2012).

## REFERENCES

- Ceresa, R.J. 1993. *The Postage Stamps of Russia 1917-23 Volume 4. Transcaucasia Parts 13-16, Section A & B, British Occupation of Batum*. Russian Philatelic Desktop Publications, Felpham, England.
- Faries, B. 1982. Stamp Printing: Wet, "Dry," and No Water at All. *S. P. A. Journal*, 44 (10): 707-708.
- A. R. Forrest, 1972. Interactive Interpolation and Approximation by Bezier Polynomials. *The Computer J* 15 (1): 71-79. Reprinted in *Computer-Aided Design* 22 (9): 527-537 (1990).
- Granzow, G. W. 2012. *Line Engraved Security Printing: the Methods of Perkins Bacon 1790-1935 Banknotes and Postage Stamps*. The Royal Philatelic Society London, London, England, p. 204.
- R. Keys, (1981). "Cubic convolution interpolation for digital image processing." *IEEE Transactions on Acoustics, Speech, and Signal Processing* 29 (6): 1153-1160.
- Lyerla, T. 2014. Scanning for Stamp Shades. *J Amer. Philatelic Soc.* 128 (7): 666-671.
- Mustacich, R. 2014. Freak or Fake? A New Fingerprinting Method for Distinguishing between Original and Fraudulent Extra Perforation of 19th Century Revenue Stamps. *The American Revenuer* 67 (1): 2-19.
- Poliakow, E.V., Poliakov, V.V., Fedotova, L.A., and Tsvetkov, M.K. 2007. High-Precision Measuring Scale Rulers for Flatbed Scanners. *Astronomy and Space Science*, M.K. Tsvetkov, L.G. Filipov, M.S. Dimitrijevic, and L.C. Popovic, eds., Heron Press Ltd., Sofia, Bulgaria. pp. 356-368.
- Nelder, J., and Mead, R. 1965. A Simplex Method for Function Minimization. *Computer Journal* 7: 308-313.
- Toppan, G. L., Deats, H. E., and Holland, A. 1899. *An Historical Reference List of the Revenue Stamps of the United States*. The Boston Philatelic Society, Boston, MA. Reprinted by Castenholz and Sons, Pacific Pallasades, CA, 1990.
- Williams, L. N., and Williams, M. 1971. *Fundamentals of Philately*. American Philatelic Society, State College, PA, p. 44.
- Zeiss 1904. [http://www.zeiss.com/corporate/en\\_de/events/international-year-of-light/optical-technologies.html](http://www.zeiss.com/corporate/en_de/events/international-year-of-light/optical-technologies.html); see also <http://blog.nasm.si.edu/planetary-science/blink-comparator/>



# Measurements of Stamp Separation Features by Digital Image Analysis

*Robert Mustacich*

---

**ABSTRACT.** Digital image analysis of perforations provides useful characterizations of stamps and the mechanical processes used to create them. Using this approach, the hole sizes, the spacing between holes, and related parameters are easily measured to micron-level precision. The 150-year history of stamp perforation is revealed by analyzing entire sheets of stamps, showing stages of improvement in the quality of rotary perforation. It is also possible to compare various types of rotary and stroke perforation, as well as the likelihood of re-perforation. Further, these analysis methods can describe other stamp-edge profiles such as rouletted and die-cut separation.

## INTRODUCTION

The analysis of perforation images was used recently to solve a mystery regarding forged extra perforation of 19<sup>th</sup> century U.S. revenue stamps (Mustacich, 2014). The focus of that effort was finding a way to measure inconsistencies in hole spacing to fingerprint each row of perforations, and determining if there was a single manufacturer of these extra perforations. The studies described in this article apply these methods more broadly to investigate perforations, and extend the image analysis to include other types of separation.

This stamp-image analysis research covers four topics: (1) Using statistical analyses of perforation features to reveal the quality of perforation over the history of U.S. federal stamp production, comparing the characteristics of different methods of perforation; (2) investigating possible stamp re-perforation; (3) applying perforation fingerprinting to modern issues; and (4) modifying the methods for the analysis of other types of stamp separation.

There are several interesting aspects of these topics. Since rotary perforators were such a difficult machine to manufacture, was there improvement in these machines over the history of perforation that is evident from examination of the stamps? For example, was there improvement that coincides with the initiative between the Bureau of Engraving and Printing and the National Bureau of Standards in the early 1980s to address the manufacturing problems? And then later, how did the transfer of perforation to private contractors in the late 20<sup>th</sup> century affect the observable characteristics of perforation? How do the characteristics of differently produced perforations compare? Example applications address several of these topics. These include suspected re-perforations, the fingerprinting of modern stroke-perforated U.S. stamps, the analysis of rouletted separations of early stamps of Finland, and the measurements of modern die-cut U.S. stamps.

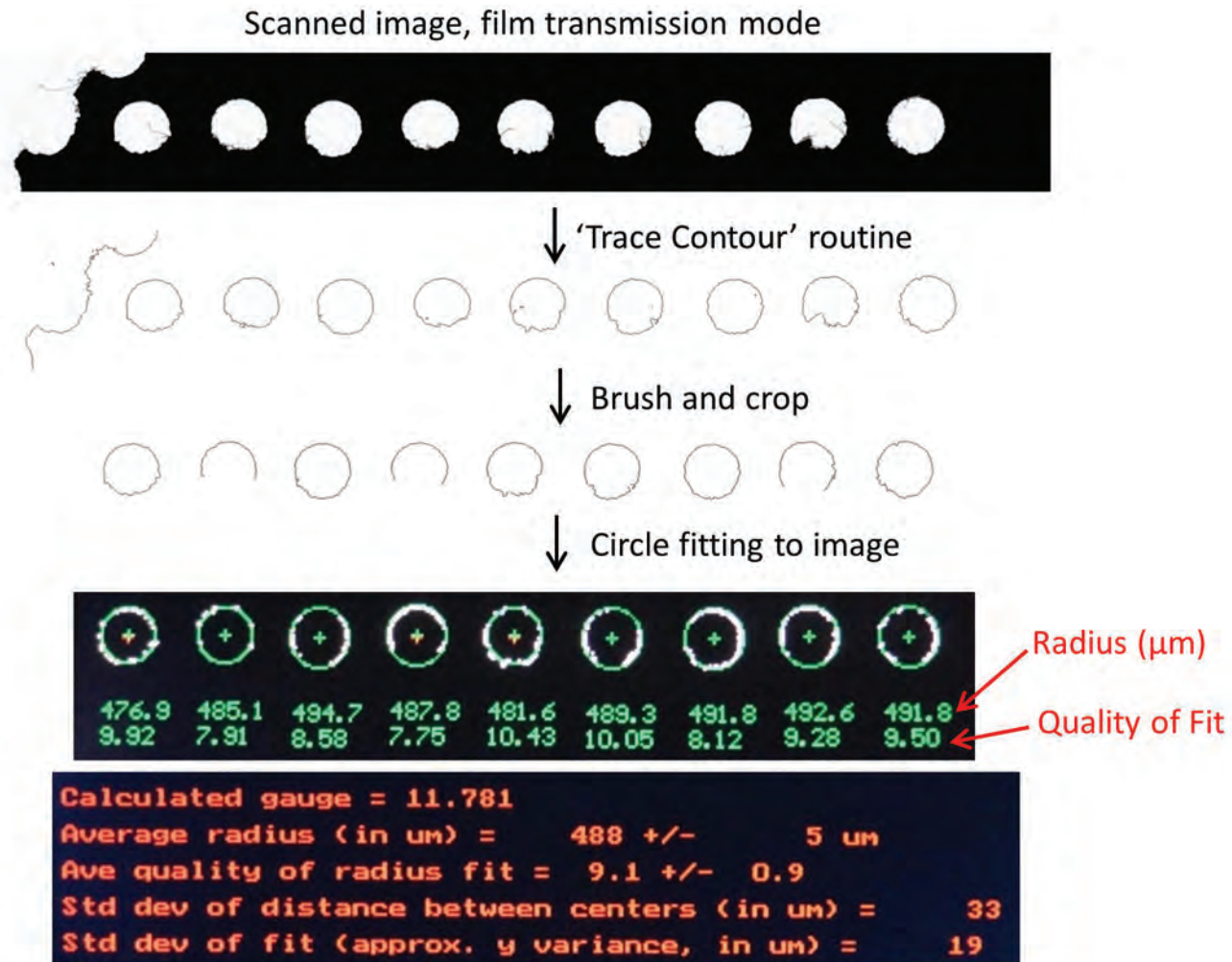

FIGURE 1. The method of analysis starts typically with a 2400 dpi transmission scan using a flatbed scanner with a film mode. The edge profiles of the perforation holes are extracted with software, and then custom software fits circles to the row of holes in the image with micron-level precision because of the two-dimensional fitting process. The software provides statistical results for the radius, hole spacing, quality of fit, and out-of-line deviation.

## BACKGROUND AND APPROACH

Philatelists are keenly aware of stamp separation, whether by perforation or other means. Since it is a key factor in judging the appearance of a stamp, it can specify stamp varieties, and it ultimately contributes to the valuation of the stamp. Modern philatelists quantify several types of separation using gauges, an innovation of the “French school” of early philatelists in the 1860s who introduced a method of gauging with no direct reference to the stamp (Williams and Williams, 1971). Using two centimeters as a typical stamp height, the modern gauge distance for counting the number of indentations was created. In the U.S., stamp experts often use the U.S. Specialist Gauge for their measurements (Weiss, 1994). Many modern gauges have continuous, sliding scales that allow measurement to fractional gauge, often in tenths.<sup>1</sup> Electronic devices are now commercially available which measure stamp gauge to the nearest  $\frac{1}{4}$

or less.<sup>2</sup> This can also be accomplished by image-analysis software which can use a variety of means to calculate a gauge from the image.<sup>3</sup>

While the use of basic gauges gained wide use after their introduction, philatelists did not widely appreciate that perforation equipment was neither designed nor manufactured to conform to the units of such a gauge. For example, the gauge of early U.S. Bureau of Engraving and Printing perforators was determined by the number of perforation pins that could be evenly spaced about the circumference of a standard steel cylinder. In the case of the flat plate printed, perf 11 Washington-Franklin stamps, this cylinder reportedly measured  $4 \frac{1}{16}$  inches in diameter (Weiss, 1994). For the early perf 12 stamps, a perforation wheel with 192 evenly spaced pins was known as a “Bureau 192” wheel (Leavy, 1918). Further, the amount of normal variation in the spacing of the separation features is often significant regarding fine measurement attempts, and

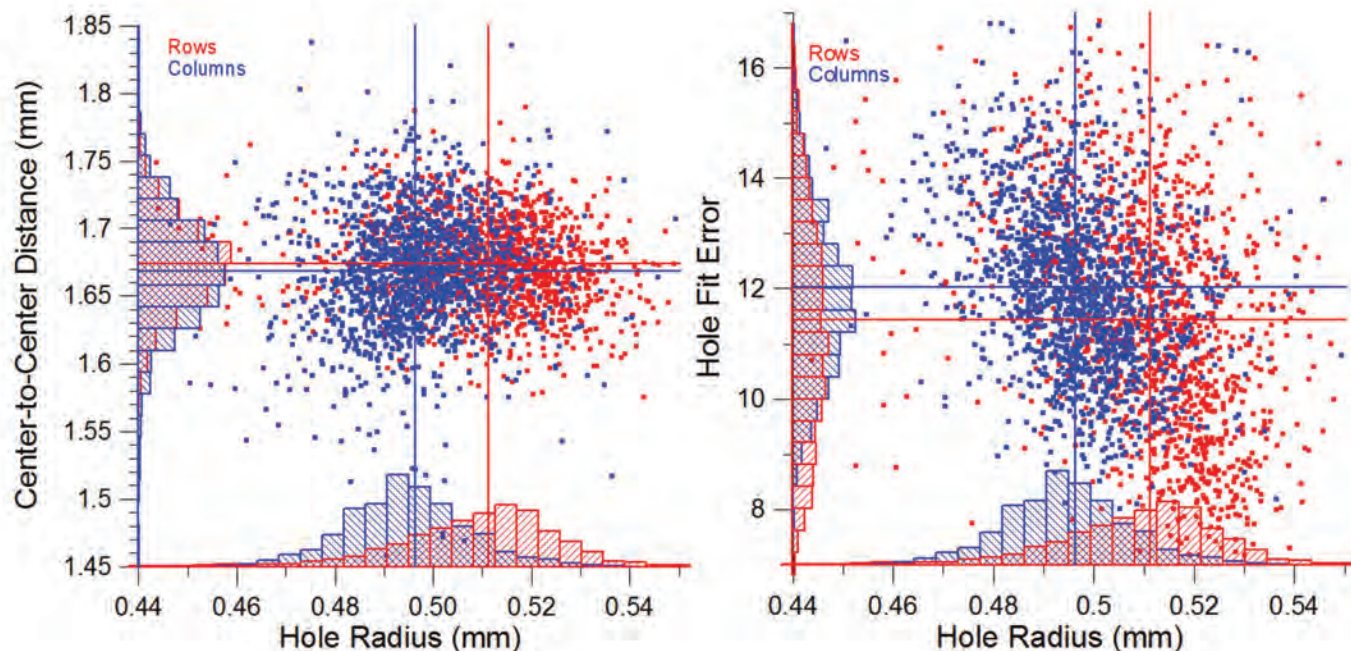

FIGURE 2. Plots showing the distributions of hole spacing and hole-fit error vs. the distributions of radius for the horizontal and vertical rows of perforation in a block of 120 of the U.S. 1 cent Proprietary First Issue revenue stamp. A large amount of variation is evident in the perforation of these early stamps, and the two “1-way” perforators differed in their distributions of the hole radii.

this was also poorly understood by philatelists. The amount of this variation is difficult to determine with a standard gauge.

The author began his studies of perforation because the fake extra perforations on 19th century revenue stamps could not be differentiated from genuine perforations by gauge. A more comprehensive analysis of images of perforation was undertaken to characterize additional features such as the individual perforation hole sizes, the spacings between successive holes, the cut of the hole, and other irregularities of the perforation (Mustacich, 2014). Figure 1 shows the sequence of steps used in this approach. First, an image of a row of perforations is captured at high resolution in a transmission (“film scanning”) mode of a Canon 9000F flatbed scanner. A resolution of 2400 dpi in a gray-scale transmission mode was found optimal. The “Trace Contours” routine in Photoshop software (Adobe Systems Inc., San Jose, CA) sharpened the image of the hole edges. This sharp edge definition resulted in a higher precision fit of circles to partial data arcs that occur with separated stamp edges. A computer program written by the author scanned the images with a mask to locate holes of the approximate size of interest starting at one edge of an image.

When a hole was found, a circle was fit to the image of the edge using a linear least squares method (Coope, 1993). While  $\pm 1$  pixel of linear resolution at 2400 dpi is  $\pm 11 \mu\text{m}$ , a two dimensional fit at high resolution gives a precision better than  $1 \mu\text{m}$  in terms of radius and coordinates in the image. This process is repeated over the length of the image to determine the hole sizes and locations for the entire row of perforations. The accurate, two-dimensional measurement of the hole centers

in the row of perforations provides statistical information such as the distribution of hole-to-hole spacings, average hole spacing (the gauge), the distribution of radii, and the distribution of transverse error from a line drawn through the centers of the holes (“zig zag error”). The sequence of the hole spacing provides an especially useful type of fingerprint. Further, the mathematical fit of a circle to the edge image of each hole gives an error measure of how much the image of the hole edge deviates from a perfect circle. While significant ellipticity was not observed with transmitted light, the roughness of hole cut varies greatly. I created the term the “hole fit error” (HFE) for this measure. Small error values are typical of sharply-cut circular holes, while rough hole edges result in higher values of the HFE (Mustacich, 2014).

In this research, entire sheets were manually scanned in short segments up to a length of 56 mm, the image width that can be viewed horizontally in the film transparency adapter of a Canon 9000F flatbed scanner. After manually pre-processing the images to extract edges, these images could be analyzed in a batch file operation, and the overall statistics were determined for the perforation of an entire sheet.

## THE ANALYSIS OF PERFORATIONS – PAST TO PRESENT

All of the perforations were measured for entire sheets.<sup>4</sup> 28 sheets were studied covering a time span from 1914 to 2007, along with a single example from the First Issue revenue



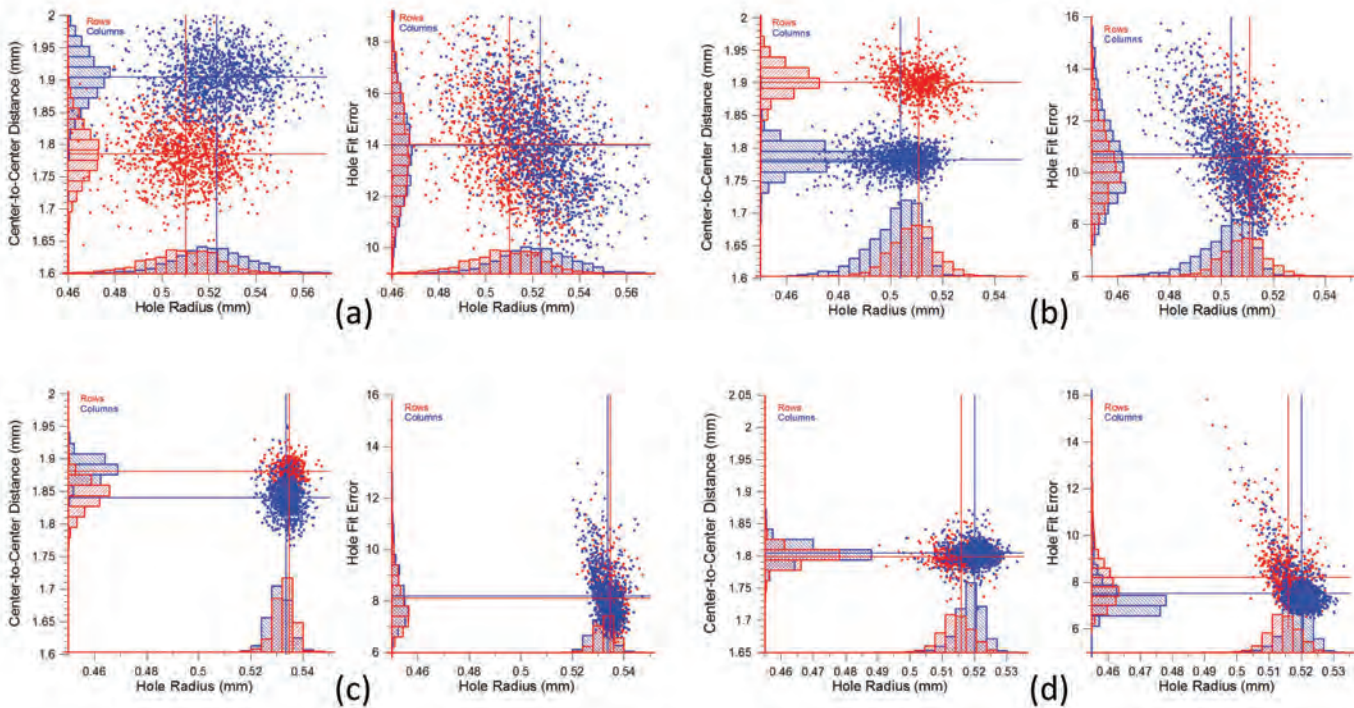

FIGURE 3. Similar plotting of the perforation characteristics determined from sheets of stamps for the following U.S. stamps: (a) The experimental electric eye perforated 2 cent Washington stamp of 1935; (b) the 1950 Statue of Freedom stamp; (c) the Van Eyck Christmas stamp of 1968; and (d) the 1975 Prang Christmas stamp perforated in-line on the Andreotti press. Both (c) and (d) used in-line rotary harrow perforation.

stamps of 1862. All sheets were with gum. Separate statistics were determined for each direction of perforation on the sheets. Figure 2 shows the results for the distributions of hole size, hole spacing, and HFE for the block of First Issue 1 cent Proprietary revenues. Plotting of the vertical perforation data (“columns”) is in blue and the horizontal perforation data (“rows”) is in red. Colored lines show average values. The early perforators used in the U.S. were rotary machines consisting of wheels with pins and matching wheels with holes. Perforation was accomplished in one direction at a time (“1-way perforation”) by passing the sheets of stamps between these matching sets of rotating wheels.<sup>5</sup> Different configurations of the wheel spacings were required for perforating the two directions of the sheet since the stamps were not square. The distributions of the hole radius in the horizontal axis on the graphs show substantial differences, indicating the use of different 1-way perforators for each direction. The angled skew of the HFE data versus hole radius observed on many plots is thought to simply be the result of rough-cut holes having smaller-appearing hole sizes. In extreme cases, a bit of remaining paper in the hole from poor punching clearly reduces the effective hole size. Hole-cut roughness is common with the earliest perforation because the perforators could only be machined to looser specifications for pin-to-hole clearance than more modern machines (U.S. Bureau of Engraving and Printing, 2013).

Stepping forward to 1914 and 1919, an analysis of sheets of revenue stamps, the offset printed Cordials, Wines, Etc.

8-cents (wmk. 191R) and the 2 cent Proprietary revenue, show very similar distributions and standard deviations to those shown in Figure 2. There appears to be little difference in the rotary perforation of these sheets.

The development of the electric eye perforation process in the 1930s had a major impact on waste reduction, reducing spoilage from approximately 35% to about 1% in 1940 using the electric eye perforators (Williams and Williams, 1971). The electric eye perforator consisted of a 1-way perforator followed by a second set of wheels fitted with bars and pins arranged similarly to the paddle wheel of a steamboat. This second set of wheels spanned by bars created perforations across the sheet. Since both directions of perforation were punched in a single pass of the sheet, the electric eye perforator was a so-called “2-way” perforator. Figure 3(a) shows the analysis of a sheet of experimental electric eye perforation of the 1935 Washington 2 cent stamp (plate no. 21149). There is a difference in the radius distributions in the two different directions, and there is a large difference in the hole spacing distributions because of the different gauges (10.5 x 11.2). The HFE distributions are similar for the two directions on this sheet, and both exhibit a moderate amount of skew due to roughness of the hole cut.

Figure 3(b) advances 15 years to an example of electric eye perforation of the 1950 Statue of Freedom stamp. The radii and the hole spacings have narrower distributions. Compared to previous examples, the hole cuts are sharper as shown by smaller peak distribution values of approximately 10 for the HFE.

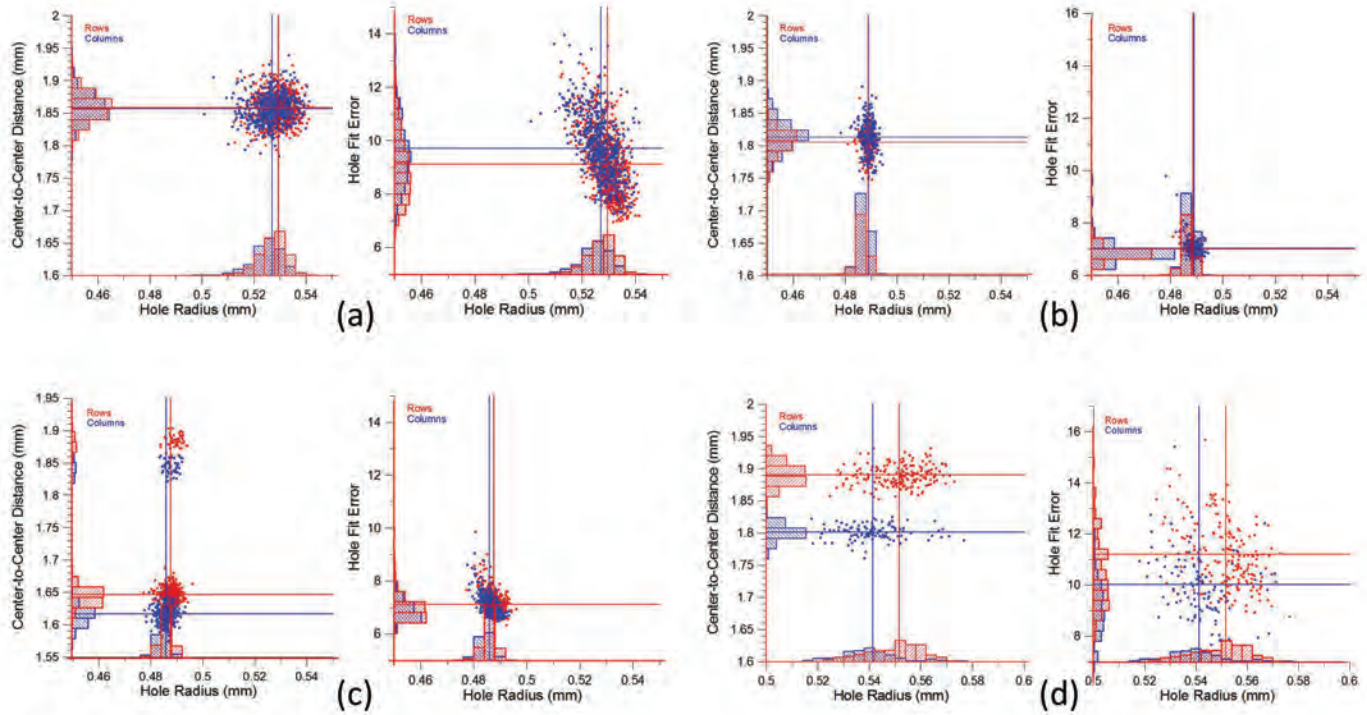

FIGURE 4. Similar plotting of the perforation characteristics determined from sheets of stamps for the following U.S. stamps: (a) The 1978 Canadian International Philatelic Exhibition sheet; (b) the 1986 Ameripex sheet (Scott no. 2216); (c) the Trans-Mississippi Centennial sheet of 1998; and (d) the Probing the Vastness of Space from year 2000 (Scott no. 3409). (a) and (b) are rotary harrow perforated, while (c) is stroke perforated, and (d) is an alternative method of rotary perforation.

Five electric eye perforators were built under contract in 1941 by the Harris Seybold Co. (Williams and Williams, 1971). These were manufactured under very exacting conditions with specially built machines operated in an air conditioned room in the Cleveland factory. Experts who have witnessed their manufacture reported that they required the closest-tolerance production machining being done in the United States (The U.S. Bureau of Engraving and Printing, 2013b). This new generation of perforators at the BEP accounts for the reduced variation in the perforation. Similar results were found analyzing a sheet of the 1960 Communications for Peace stamps.

In 1968 the BEP installed a new generation of presses, the nine-color Huck press, which included in-line perforation. The perforation was of a rotary harrow design producing perfect corners on the stamps. The analysis of an example of the perforation from this press is shown in Figure 3(c) for the Van Eyck Christmas stamp of 1968. There is a significant reduction in the hole spacing and radius distributions. In-line rotary harrow perforation was added to the Andreotti press in 1975. Prior to this time, stamps printed on the Andreotti press were perforated off-line with a Seybold electric eye rotary web-fed perforator (Hotchner, 1989). One of the 1975 issues that was rotary harrow-perforated in-line with the Andreotti press was the Christmas card stamp featuring an early design by Louis Prang. This stamp is well known for being the first of the modern multiple perforation issues (Kitson, 1988). The example in Figure 3(d) shows the analysis of the rotary harrow-perforated

variety of this stamp. The distributions of the radii and the hole spacing are similarly narrow. Median values of 8 or less show that the holes are sharply cut; however, a few of the holes have some irregularities that result in a skewed scatter plot for a small portion of the data. The electric eye perforated 1975 Prang Christmas card stamps provided measurements similar to the electric eye perforated example in Figure 3(b). The L perforated stamps of this issue exhibited distribution widths more similar to the harrow perforated stamps in the horizontal direction, and distributions more like the electric eye perforated stamps in the vertical direction.

The demand by the BEP for contractors to meet ever smaller tolerances in the manufacture of perforation cylinders led to a shortage of bidders in the 1970s. For some time, the only willing bidder for hand-crafted cylinder sets was an Italian firm, but with delivery times on the order of two and one half years. When it became clear that the Italian firm could not deliver harrow perforation cylinders for a large sheet of stamps with irregular sizes for a scheduled philatelic exhibition in Canada, the BEP turned to the National Bureau of Standard (NBS) for help. NBS agreed to take on the job on a best efforts basis, provided the BEP funded the effort. The tolerance specification was relaxed from the requested 0.001 inches to 0.002 inches, a tolerance NBS still considered beyond their current capabilities. NBS assembled a team that produced a pair of the cylinders to the 0.002-inch tolerance just in time for the BEP to produce and deliver half of the promised sheets on the first

day of the exhibition (NIST, 2001; Bergstrom, 1984). From the descriptions in these references it appears that the exhibition sheet was for the 1978 Canadian International Philatelic Exhibition in Toronto.<sup>6</sup> Figure 4(a) shows measurements from one of these sheets. If this was the product of an early pilot effort by NBS, it appears that they achieved results very similar to the quality of the previous rotary harrow perforations shown in Figures 3(c) and 3(d).

The late 1970s effort by NBS to machine perforation cylinders set in motion a project at NBS to meet the challenge of the original 0.001-inch tolerance limit. Two private industry companies had already failed in their attempt to develop drilling machines to meet this target. Using numerically controlled machining to account for 23 different sources of error with an array of sensors, controlled-temperature environments, and new methods to detect drill bit fatigue, the NBS developed the astounding capability to drill one of these cylinders with 16,844 holes 8.13 mm deep of 1.09 mm diameter in 40 hours to these specifications. Based on their instrumentation control developments, the ability to achieve an accuracy of  $\pm 0.0002$  inch seemed possible (Bergstrom, 1984). The timing and the dissemination of the NBS results to potential BEP contractors is not clear, but these efforts surely factored into the ongoing efforts to manufacture improved perforators.

However, it appears that the speed of perforation has always been trying to catch up to the speed of printing presses. Production bottlenecks, especially with in-line perforation which could slow or halt a press, were a perpetual problem. For this reason, the BEP made the decision in the 1980s to perforate off-press as much as possible, and to purchase new presses without in-line perforators (Hotchner, 1989). So for stamps later than the 1970s, an increasing array of equipment and parties were involved in the production and perforation of stamps, especially as more production was contracted outside of the BEP.

In 1985 the Bobst-Champlain perforator was introduced using a Eureka bullseye die for off-line stroke perforation. In the stroke process, pins in a bar or plate descend linearly to perforate the paper, analogous to the common 3-hole paper punch. Figure 4(b) shows the analysis of a sheet from the 1986 Ameripex issue, sheet I, perforated by this process. It is immediately apparent that the distributions of hole radius and HFE are both very narrow, with a small amount of spread in the hole spacing. In fact, the holes are exceptionally well cut and have some of the smallest HFE values observed. The results are very similar with the 1995 American Kestrel 1 cent stamp, also perforated with the Eureka die. While it also shows similarly sharp cut holes, it also shows more spread in the distribution of the hole spacings.

Figure 4(c) shows another example of an off-line stroke perforator used on U.S. stamps, the Wista BPA 9070 stroke perforated Trans-Mississippi Centennial sheet of 1998. The gauge is approximately  $12.2 \times 12.4$  for the stamps, with a few more widely spaced holes filling the gaps in the sheet between the nine stamps. The distributions are narrow for the radii, HFE, and the hole spacings in this case. Analysis of examples of Wista stroke perforation for the 2001 Enrico Fermi stamp and the 2002 Hawaiian Missionary stamp show very similar results to those observed in Figure 4(c). In the steady transition to die-cut stamps from perforated stamps, one of the late examples of perforation is the 2007 Flag stamp. This Wista

stroke-perforated stamp has more spread in the hole spacings than the other three Wista stroke-perforated examples discussed and some slight skew and roughness to a small number of the holes, but is otherwise similar to the other Wista perforated examples.

The analysis of a recent rotary perforated stamp with very different characteristics is shown in Figure 4(d). This example, the 2000 Probing the Vastness of Space sheet, was perforated with the Ab Production Svenska (APS) rotary perforator. This perforator uses a method related to the Swedish “lawnmower”; the paper is indented from the front and then cut on the backside with a cylindrical cutter (Myall, 2003). This process leaves a small amount of raised powdered paper and gum on the backside of the stamps. The indenting and cutting results in a large hole radius.

Figure 4(d) shows a relatively wide dispersion of radii and HFE, evidently resulting from variation in this process. The distribution of hole spacings is relatively narrow, though. An analysis of another APS rotary-perforated stamp, the 1998 American Folk Music (Folk Singers) issue, shows very similar results, but with less spread in the values for the radii and HFE for perforation in the horizontal direction.

Table 1 contains a tabulation of the results for the 29 sheets of stamps. For each issue this table includes the separate statistical averages and standard deviations of the characteristics of the vertical and the horizontal perforations. The table presents these characteristics in the following order: the average radius (R) and the standard deviation of the radii ( $\sigma_R$ ), in mm; the average spacing (d) and the standard deviation of the spacing ( $\sigma_d$ ), in mm; the gauge calculated from the average spacing; the average hole fit error (HFE), and the standard deviation of the HFE ( $\sigma_{HFE}$ ); and the standard deviation of the transverse (“zig zag”) error ( $\sigma_T$ ), in  $\mu\text{m}$ ; next, this information then repeats for the other perforation direction; and a description of the type of perforator used, where “R 1-way” denotes a basic uni-directional rotary perforator, “R 2-way” denotes perforation accomplished in both directions in a single pass such as the electric eye perforator, R denotes rotary perforation of unspecified type, RH denotes rotary harrow perforation, and S denotes stroke perforation.

Figure 5 presents plots of the standard deviations of the hole placements for post-19<sup>th</sup> century examples contained in the table. As mentioned above, the 1941 production of the electric eye perforators by the Harris Seybold Co. met new standards of precision in temperature controlled environments. This is evident in the reduced sizes of deviations in both hole spacing and zig-zag error due to improved precision in hole placement. After this innovation, little changed in rotary perforators until after 1980. There was an overall reduction in the variance of the hole spacing in rotary perforators after the early 1980s BEP-NBS program, based on the sheets tested in this study. There was also reduction in the transverse hole-placement error.

The BEP-sponsored NBS program spawned a number of award-winning improvements to the field of precision machining (NIST, 2003); the data in Figure 5 suggest that the program did have an impact on the machining of rotary perforators. By 2000, the level of precision had risen to match the best of the stroke perforators. If we consider the rotary perforators to be



TABLE 1. Measurements from a survey of 29 different sheets of stamps. Separate statistics were calculated for vertical and horizontal perforations on the sheets. The table contains the following sequence of information for each direction of perforation: The average value and standard deviation of the radius in mm; the average value and standard deviation of the hole spacing in mm; the calculated gauge; the hole fit error (HFE) and its standard deviation; and the standard deviation of the transverse (“zig-zag”) error in  $\mu\text{m}$ .

Issue date	Issue	Scott No.	vertical perforations								horizontal perforations								PERFORATOR	NOTES
			R (mm)	$\sigma_R$ (mm)	d (mm)	$\sigma_d$ (mm)	gauge	HFE	$\sigma_{HFE}$	$\sigma_T$ ( $\mu\text{m}$ )	R (mm)	$\sigma_R$ (mm)	d (mm)	$\sigma_d$ (mm)	gauge	HFE	$\sigma_{HFE}$	$\sigma_T$ ( $\mu\text{m}$ )		
1862	Proprietary revenue, 1 cent	R3	0.496	0.014	1.668	0.044	11.99	12.0	1.5	20	0.511	0.016	1.674	0.033	11.95	11.5	2.0	18	R 1-way	Large block of 120
1914	Cordials, Wines, w 191R, 8c	RE25	0.518	0.012	2.016	0.038	9.92	12.5	1.6	28	0.514	0.011	2.010	0.037	9.95	11.4	1.5	25	R 1-way	
1919	Proprietary revenue, 2 cent	RB66	0.488	0.017	1.828	0.040	10.94	13.2	1.5	28	0.511	0.014	1.833	0.036	10.91	13.0	1.7	21	R 1-way	
1935	Washington 2c	634	0.523	0.016	1.904	0.040	10.50	14.0	1.9	23	0.510	0.016	1.786	0.043	11.20	14.0	1.8	25	R 2-way	Experimental electric eye
1940	Pony Express, 80th Anniv.	894	0.533	0.010	1.905	0.042	10.50	11.7	1.7	15	0.514	0.013	1.781	0.045	11.23	13.2	1.8	22	R 2-way	
1950	Statue of Freedom	989	0.504	0.010	1.782	0.020	11.22	10.7	1.6	15	0.511	0.008	1.901	0.025	10.52	10.6	1.4	13	R 2-way	
1954	Documentary revenue, \$1	R667	0.497	0.020	1.836	0.026	10.89	12.9	1.8	19	0.489	0.017	1.836	0.033	10.89	13.9	1.5	20	R	
1960	Communications for Peace	1173	0.516	0.011	1.905	0.026	10.50	10.7	1.6	14	0.513	0.007	1.781	0.015	11.23	8.8	1.2	10	R 2-way	
1968	Christmas, Van Eyck	1363	0.535	0.004	1.880	0.020	10.64	8.1	1.0	12	0.534	0.004	1.840	0.026	10.87	8.2	1.0	13	RH	Huck press, in-line
1970	Fort Snelling	1409	0.499	0.013	1.836	0.025	10.89	10.9	1.5	15	0.522	0.009	1.839	0.026	10.88	9.3	1.2	13	R 1-way	
1975	Christmas Card, Prang	1580	0.520	0.004	1.804	0.014	11.09	7.5	0.8	8	0.516	0.005	1.799	0.014	11.12	8.2	1.1	8	RH	Andreotti press, in-line
1975	Christmas Card, Prang	1580B	0.513	0.009	1.782	0.021	11.22	9.1	1.6	25	0.509	0.011	1.905	0.028	10.50	10.7	1.4	15	R 2-way	
1975	Christmas Card, Prang	1508C	0.515	0.007	1.845	0.023	10.84	9.1	1.3	15	0.521	0.004	1.840	0.017	10.87	7.5	0.7	13	R 1-way	L perforator
1976	American Bicentennial	1686	0.533	0.006	1.811	0.024	11.04	9.6	1.4	11	0.532	0.006	1.808	0.038	11.06	10.0	1.4	12	RH	
1978	Canadian Int'l Phil. Exhib.	1757	0.529	0.005	1.858	0.021	10.76	9.1	1.2	12	0.527	0.006	1.857	0.021	10.77	9.1	1.2	17	RH	
1980	Dorothea Dix	1844	0.505	0.011	1.799	0.030	11.12	12.4	1.8	19	0.509	0.008	1.794	0.031	11.15	10.7	1.5	18	RH	"A" combination press
1982	State Birds and Flowers	1953A-	0.495	0.015	1.801	0.024	11.10	12.5	1.9	19	0.495	0.013	1.799	0.036	11.11	12.3	1.7	21	RH	
1986	Ameripex '86 Sheet I	2216	0.489	0.002	1.813	0.025	11.03	7.0	0.3	12	0.489	0.002	1.805	0.020	11.08	7.0	0.2	12	S	off-line Eureka
1991	American Kestrel	2476	0.510	0.004	1.840	0.018	10.87	7.9	0.9	8	0.510	0.004	1.836	0.016	10.90	7.6	0.9	8	R 1-way	L perforator
1991	American Kestrel	2477	0.493	0.002	1.804	0.032	11.09	6.7	0.1	21	0.493	0.002	1.792	0.026	11.16	6.7	0.3	19	S	off-line Eureka
1994	Legends of the West	2869	0.481	0.006	1.982	0.011	10.09	8.3	1.3	17	0.473	0.006	1.972	0.020	10.14	9.5	1.4	11	S	sheetfed stroke
1998	1898 Trans-Mississippi Cent.	3209	0.486	0.003	1.616	0.013	12.37	7.1	0.4	8	0.488	0.002	1.647	0.011	12.15	7.1	0.4	9	S	Wista BPA 9070 stroke
1998	American Folk Music	3212-5	0.514	0.010	1.963	0.009	10.19	8.2	1.0	4	0.503	0.005	1.982	0.011	10.09	7.7	0.8	4	RH	Ab Produktion Svenska
1998	Weather Vane	3257	0.487	0.005	1.783	0.015	11.22	8.6	1.0	11	0.486	0.004	1.800	0.017	11.11	8.6	1.0	9	RH	
2000	Stars and Stripes	3403	0.490	0.007	1.836	0.011	10.89	9.3	0.9	6	0.495	0.010	1.799	0.036	11.11	12.3	1.7	8	RH	
2000	Space - Probing the Vastness	3409	0.541	0.011	1.801	0.011	11.10	10.0	1.4	10	0.552	0.011	1.890	0.016	10.58	11.2	1.3	8	RH	Ab Produktion Svenska
2001	Enrico Fermi	3533	0.489	0.002	1.802	0.011	11.10	7.0	0.3	7	0.489	0.003	1.796	0.013	11.13	6.9	0.3	10	S	Wista stroke
2002	Hawaiian Missionary Stamps	3694	0.490	0.002	1.802	0.013	11.10	7.1	0.4	8	0.492	0.002	1.830	0.011	10.93	6.9	0.2	10	S	Wista stroke
2007	Flag	4129	0.483	0.002	1.797	0.018	11.13	7.2	0.4	11	0.484	0.002	1.778	0.026	11.25	7.1	0.4	16	S	Wista stroke

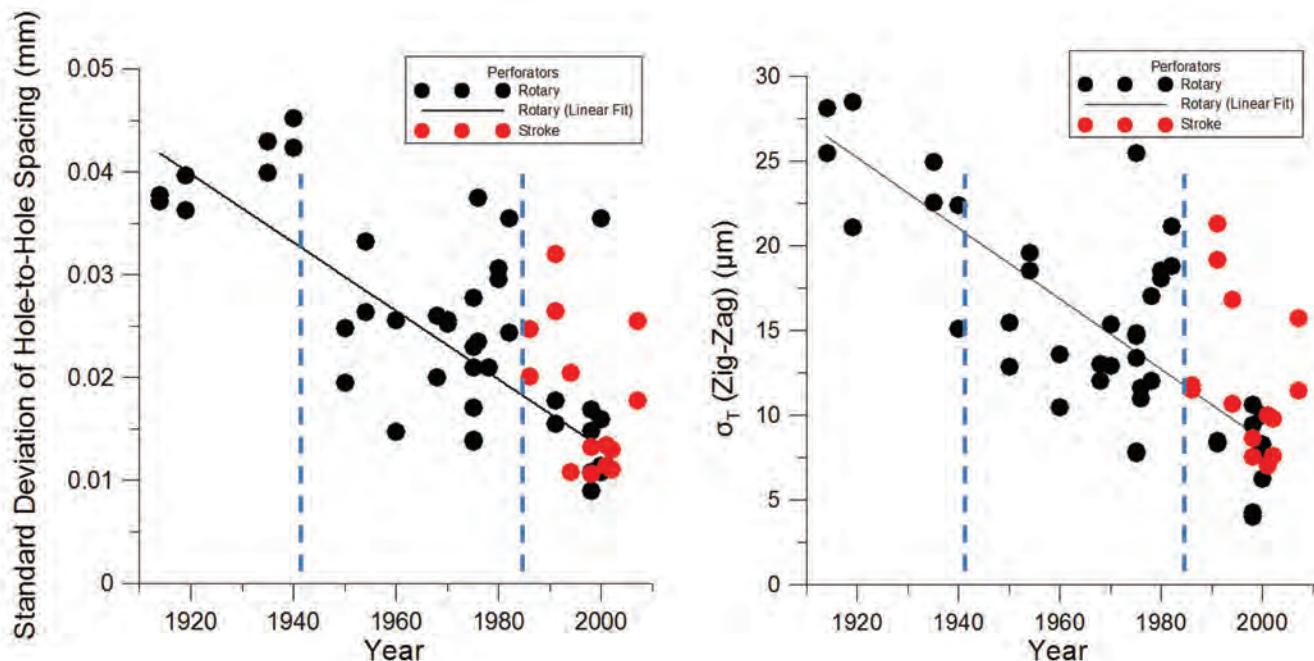

FIGURE 5. Plots showing the improvement over time in the precision of hole placement in rotary perforation as revealed from the characterization of sheets of stamps. Both the standard deviation of the hole spacing and the transverse (zig-zag) show reductions that correlate with two documented improvements to perforator fabrication: (1) the environmental control of temperature during machining in 1941; and (2) the numerically controlled machining project at the National Bureau of Standards for manufacturing perforators in the early 1980s.

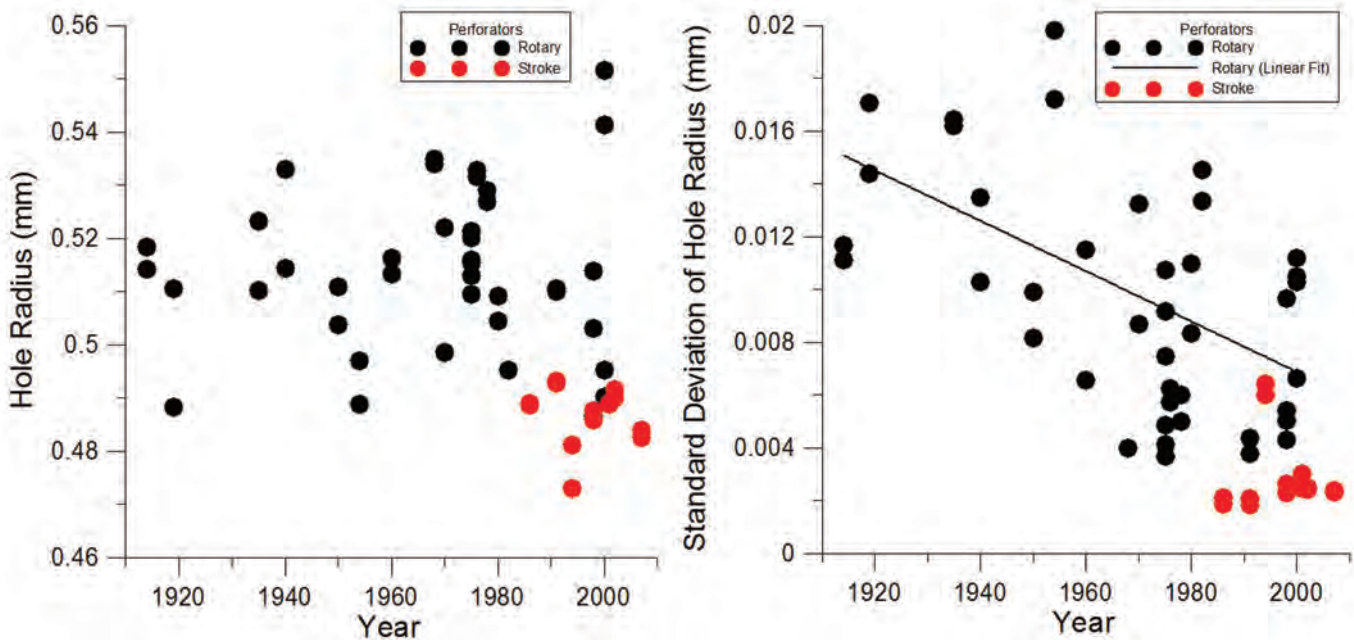

FIGURE 6. Plots of the perforation hole radius and its standard deviation over the last century. While the hole radius has remained relatively constant with rotary perforation, the typical size is larger than the hole sizes measured for stroke perforation. Reduction in the radius deviation is expected from the improvements in machining tolerances.

intrinsically more difficult to machine, this data speak highly of the precision gains realized in fabricating rotary perforators.

The hole radius of the perforation is approximately constant over this time span as shown in Figure 6. The BEP does not have pin diameter information for perforators prior to 1940, but stated that a pin diameter of 0.042 inch (533  $\mu\text{m}$ ) has been standard since that time, with target hole diameters of 0.043 inch (546  $\mu\text{m}$ ), at least as of 1964 (BEP, 2013a). A curious fact is that punched hole sizes tend to be nearly the size of the pins, but can be smaller than the actual pin size (BEP, 2013a; Mustacich, 2015).<sup>7</sup> On average the rotary perforations through 1991 in the table show a radius about 4% less than the standard pin. The stroke perforators appear to have a metric pin diameter of 1 mm, and observed hole size similarly about 3% less than the pin size.<sup>8</sup>

The standard deviation of the hole radii produced by rotary perforation shows on average a gradual decline over the century, likely the result of steady improvements in the manufacture and perhaps maintenance of equipment. There are no sudden improvements, as there was following the NBS program in the early 1980s. The hole-fit error (HFE), indicative of the sharpness of the hole cut, also improved gradually over the century as shown in Figure 7(a). It probably benefited from gradual reductions in pin-to-hole clearances, owing to improved positional accuracy in machining. The stroke perforators mostly have lower and similar HFE values. By their very design, the accurate positional drilling of a smaller array of holes on a flat sheet should be a faster and less demanding task, so it is perhaps not surprising to see the data for stroke perforators tightly clustered. Specification of current Wista

stroke perforation products quote perforation and repeating accuracies of  $\pm 0.001$  mm.<sup>9</sup> This is significantly lower than the least positional variation observed in Figure 5, but other variables such as changes to the paper may contribute to the minimum variance that may result in finished stamps.

Figure 7(b) shows that the data for stroke perforations clusters together when hole radius and HFE are plotted together. The studied stroke perforations have a unique combination of sharp hole cuts combined with their small hole sizes.

## STATISTICAL ANALYSIS OF RE-PERFORATIONS

Statistical analysis of perforations can reveal anomalies in stamps suspected of re-perforation. Typically, the characteristics of perforations on opposite sides of stamps should be most similar as these normally match in gauge and are done by the same perforator. One can readily analyze most undamaged stamps in this way.

Using pairs of plots similar to the ones presented in the previous section, Figure 8(a) shows an example of a three cent U.S. parcel post stamp for which the right edge perforations have anomalous characteristics. While the other three edges' characteristics appear to have similar distributions, the right edge has narrower distributions of the radii, hole spacings, and HFE. The average value of the HFE for the bottom edge is also much smaller. These anomalies suggest re-perforation of the right edge.

The next example for the three cent Washington third Bureau issue in Figure 8(b) displays anomalous hole sizes for the



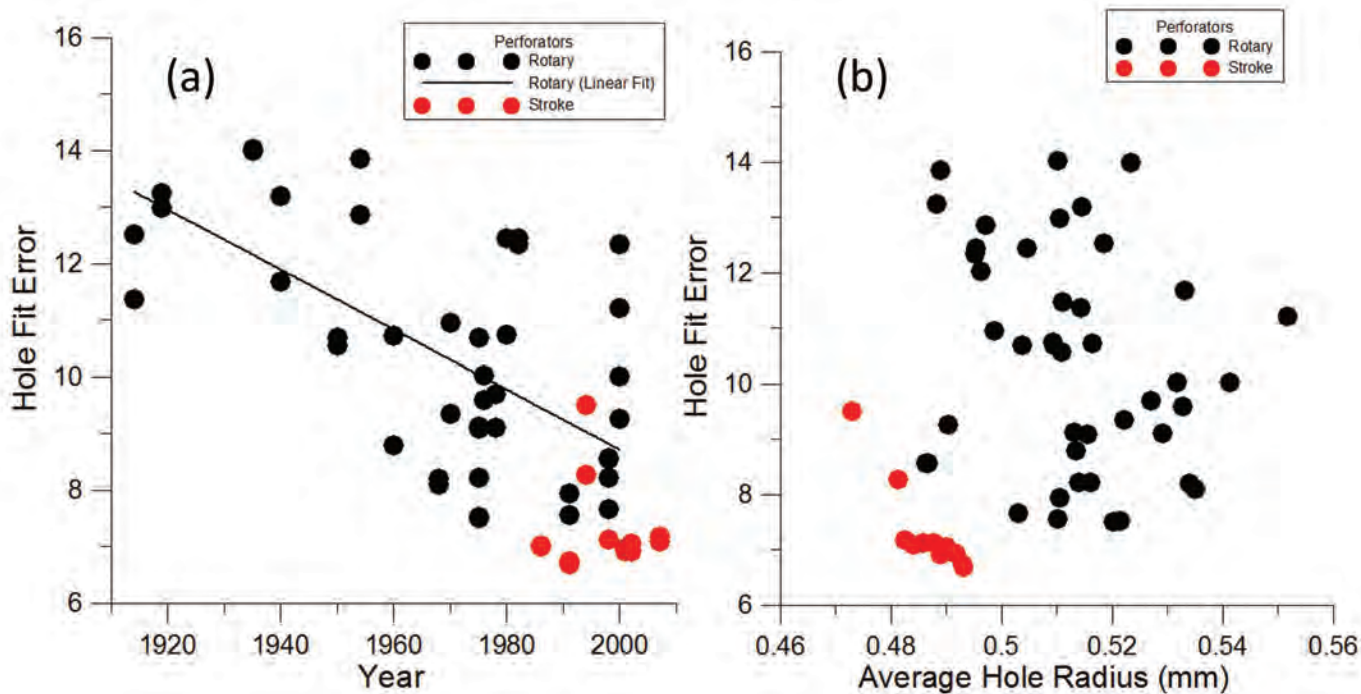

FIGURE 7. The reduction in the hole fit error reflects the gains realized in smaller machining tolerances. The stroke perforations analyzed in this study have a combination of smaller hole size and more perfect hole cut.

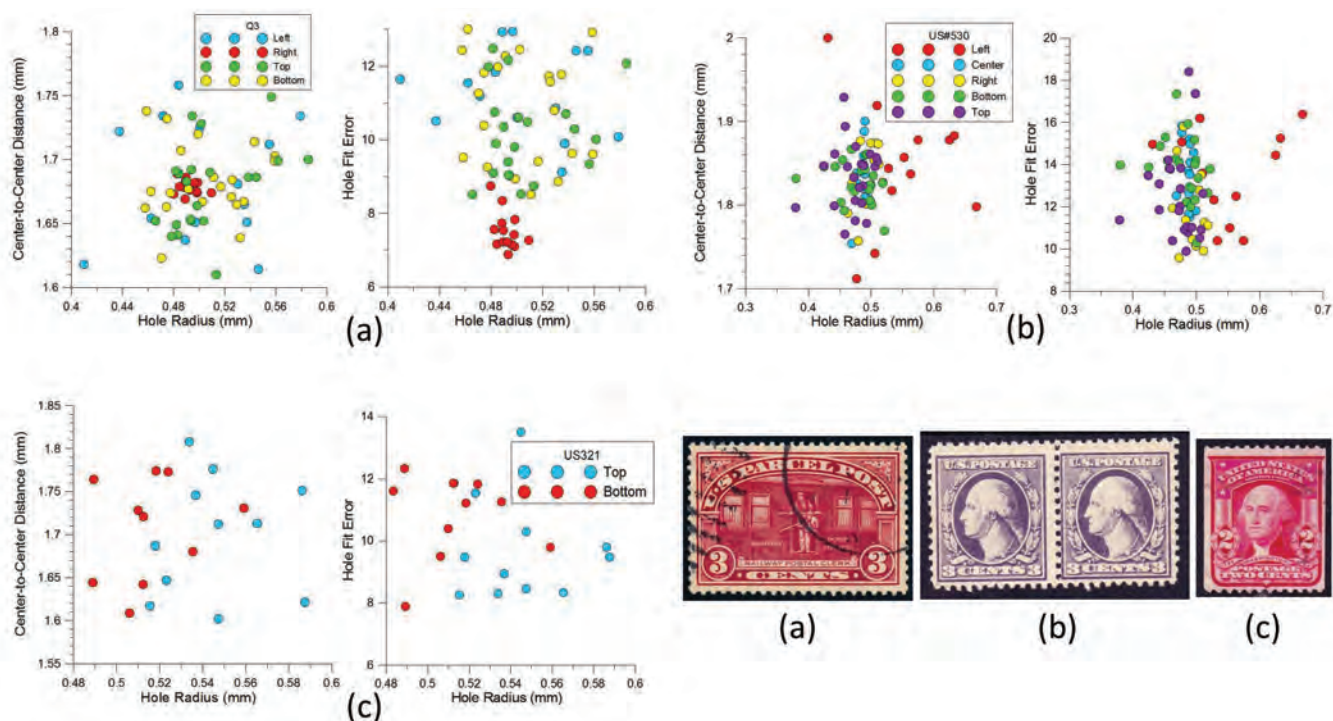

FIGURE 8. Similarly constructed plots comparing the edges of the same stamp for uncharacteristic or greatly differing perforation properties. The three illustrated stamps display the following anomalies: (a) the distributions for the right edge are uncharacteristically narrow with a too perfect cut; (b) the left edge has too wide a range of radii; and (c) the two edges have greatly different distributions of hole radii.



left edge perforations. The other three edges have very similar characteristics, and all edges have similar gauge measurements. However, the distance between the vertical rows of perforations for the stamp on the left is 1.5 mm wider. This suggests that a margin with a straight edge was probably re-perforated on the left stamp.

One final example shows what is a likely re-perforated stamp to imitate a 1908 two cent Washington coil rarity. The distributions in Figure 8(c) for the top and bottom edge radii poorly match. The poor matches lead one to believe that this stamp was probably an imperforate variety of this stamp with trimmed sides and added perforations at the top and bottom.

## FINGERPRINTING STROKE PERFORATIONS

My original investigation of 19<sup>th</sup> century revenue stamps with perforation forgeries pointed to the use of a stroke perforator. I developed image analysis methods for this project to detect perforation fingerprint patterns (Mustachich, 2014). Stroke perforations lend themselves very well to fingerprinting because of the large amount of repetition of the imperfect pin spacing pattern peculiar to the perforator. Regarding the different examples in Table 1 of stroke perforations, these all are amenable to fingerprinting. Because they all fingerprint in similar ways, one example is sufficient to demonstrate the general approach.

Comb perforation is a type of stroke perforation frequently encountered in which one or more rows are punched in a sheet at a time, each with a “comb” of rows at right angles. Figure 9(a) shows the sequence of a 2-hop comb by a Wista stroke perforator on an example sheet of the U.S. 2007 Flag stamps (Scott no. 4129). The comb pattern is shown at the right. The 10 x 10 sheet of stamps has eleven vertical rows of

perforation, so six uses of the comb are required, with one use partially off the cut sheet. The small inconsistency in the perforation spacing where successive comb patterns meet indicates that the right edge vertical row on the sheet corresponds to the vertical row of the comb labeled “1.” Consequently, the vertical comb hole-spacing pattern “1” repeats itself on the sheet six times as illustrated across the sheet, and vertical comb pattern “2” repeats five times.

The vertical perforations were scanned in 5 sections labeled A-E, a total of 55 images. The hole spacing patterns from the images should match up as 5 groups of 6 patterns, and another 5 groups of 5 patterns.

After analyzing and fingerprinting hole spacings for the 55 images, a computer tested all possible alignments of the patterns. Each possible alignment of a pair of fingerprint patterns is given a score equal to  $n / \sum |a_i - b_{i+j}|$ , where  $n$  is the number of overlapping hole spacings,  $a_i$  and  $b_i$  are the sequential hole spacings of the fingerprints, and  $j$  is a varying offset as the overlap is shifted to determine the best matching. A minimum overlap of 8 components was required to avoid large matching scores from coincidental matches with very short overlap sequences. Including the factor of  $n$  in the matching score introduces a modest weighting that favors more fingerprint overlap, and small total differences in the denominator with good matches result in high values for the score. Using a threshold for the score, higher values are passed to a program to plot the network of matches.<sup>10</sup>

Figure 9(b) presents the network graph for the fingerprint matches. The figure includes matches with scores exceeding the threshold. The points in the figure represent fingerprints, each labeled to identify which section of the row of perforations it belongs to. Lines connecting the points represent fingerprint matching scores which exceed the threshold, wider

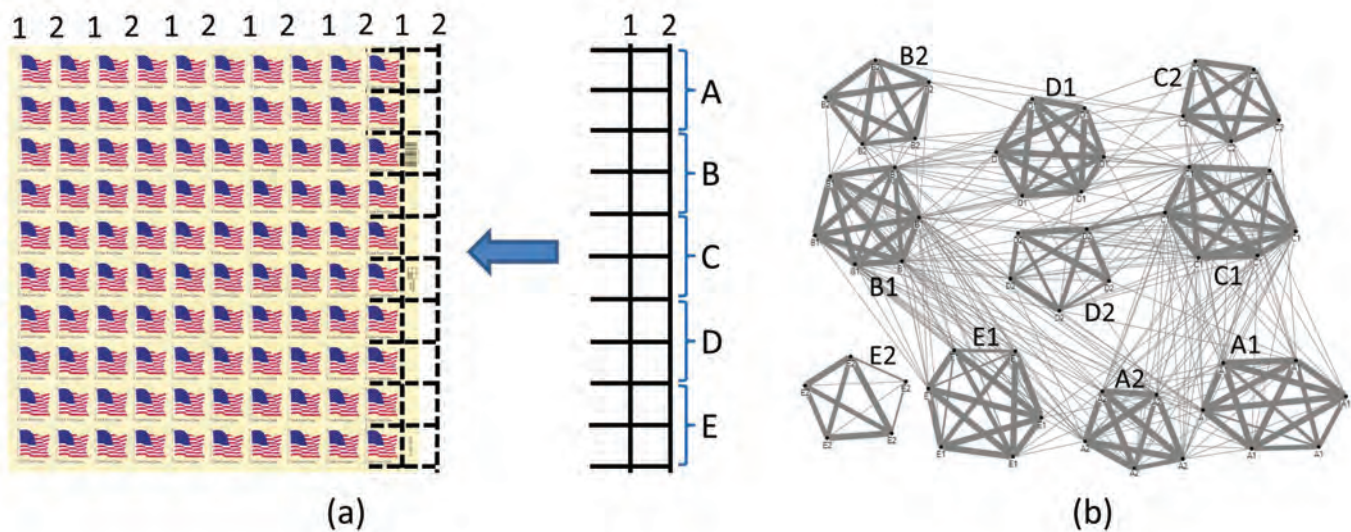

FIGURE 9. A sheet of the 2007 Flag Issue showing the travel of the 2-hop comb in (a) used to stroke perforate the sheet. All of the vertical perforations were scanned in five sections, A-E. The repetition of the comb should result in 6 strikes of the comb’s column 1, and 5 strikes of the comb’s column 2 for each of the sections. Fingerprinting using the imperfections in hole spacing correctly matches up the 55 segments as shown by the clusters of matching fingerprints (wide lines indicate very strong fingerprint matches) in (b).

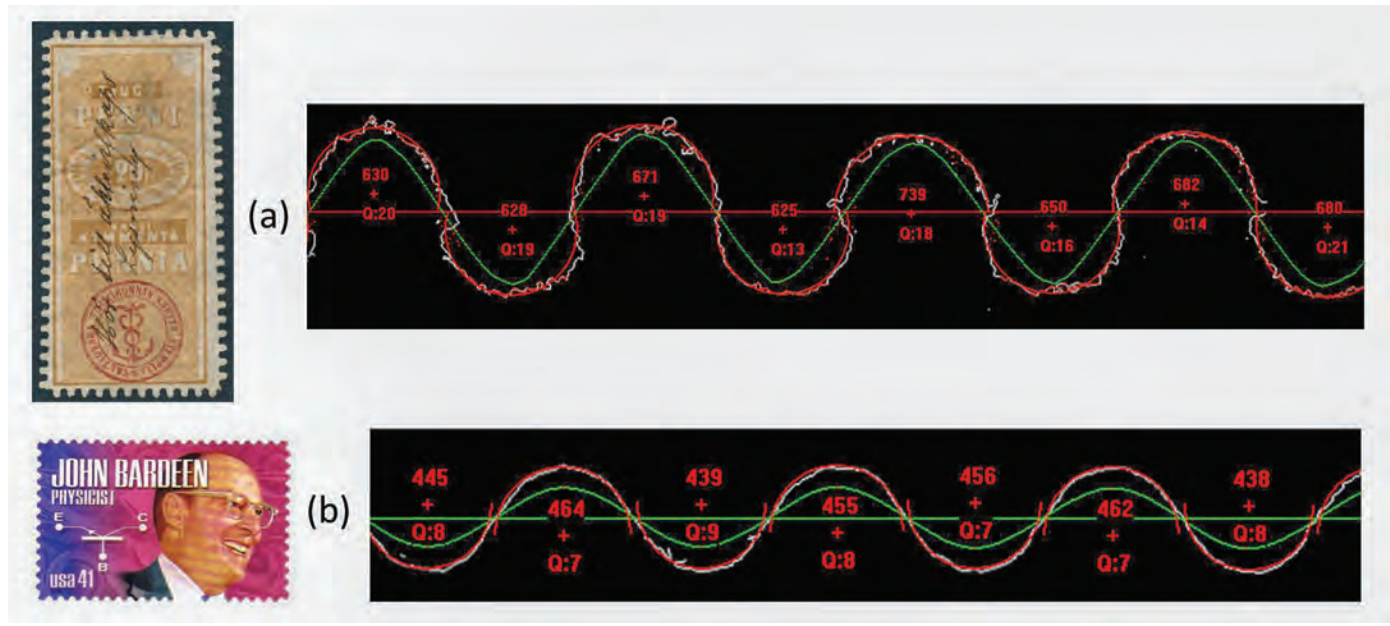

FIGURE 10. Two examples showing a modification of the methods for the analysis of other types of stamp separation profiles. The early Finland revenue stamp has long, sometimes interlocking roulettes, while the modern die-cut example has a very regular profile. The same curve-fitting routines can be applied with partial arcs to the tops and bottoms of the edge profiles to characterize the shapes, peak-to-trough “amplitudes,” and the roughness of cut.

lines representing much higher scores. As is visually evident in the network graph, the strongest matches define a set of 6 matching fingerprints and a set of 5 matching fingerprints for each row A to E. Nearly all of the strong correlations in the graph are with their own group. Because the modern perforations are relatively precise in their pin spacings, the general similarity of fingerprints results in a moderate amount of background correlation shown by the fine lines. Less perfect, older perforation equipment allows the use of lower thresholds with greater rejection of coincidental background correlation because the typical fingerprints differ much more. Nonetheless, higher thresholds can be used with more perfect perforation equipment as in this example to extract the networks from the fingerprint data and apply fingerprinting to modern stamps.

**MEASURING OTHER TYPES OF STAMP SEPARATION**

The image analysis methods can be adapted to the analysis of other types of separation such as roulettes and die cuts. The linear algebraic methods for fitting circles to data apply as well to the arcs in the peaks and troughs of wave-like images.<sup>11</sup> Good fits of partial circular arcs to the turning points of wave-like profiles then defines the periodic spacing of the wave peaks and troughs, the approximate width and shape of the wave extremes, and the crest-to-trough height, or “amplitude,” of the wave. The individual data for each peak and trough also provide measures of the variability of these quantities, and their sequences can provide fingerprinting information. The

following two examples illustrate such measurements with both old and new stamps having wave-like edges.

The early stamps of Finland offer many examples of serpentine roulettes that were hand cut with tools consisting of a handle with a cutting wheel (Linder and Dromburg, 1983). Small paper bridges were left uncut to keep the stamps from fully separating. Rouletting wheels were individually crafted and maintained; consequently, there is a large variation in the rouletted separations found on these stamps. Both postage stamps and revenue stamps were rouletted in this manner. Analysis of the shapes from an edge of a 19<sup>th</sup> century 20 penia Finland revenue stamp is shown in Figure 10(a). The images were scanned and pre-processed in the same resolution and manner as described above for the perforation images. While the modern die cut stamps are very regular, the early Finnish roulettes require some special considerations. Irregularities are common in the area of the paper bridges that have been torn away in the separation. The algorithms for sequential analysis of the features in the entire image also need to accommodate the frequently missing “teeth” in the study of these stamps. Additionally, all of the rouletting of these stamps has slight curvature, and the images must be corrected so that the peaks and troughs can be accurately described without distortion from this curvature.

The removal of any overall curvature of the roulettes was accomplished by fitting the entire length of the roulette to a parabola, which consists of three terms. The small quadratic term corrects for curvature, the linear term corrects for tilt of the roulette in the image, and the constant term centers the roulette in the image. In the next step, a smoothed view of the

roulette using a centered average, shown in green, is calculated to obtain an indication of the presence of a peak or trough in the roulette, and the approximate location of these features. This greatly simplified the challenge of properly locating and launching the circle-fitting routines. These routines were constrained to fit partial arcs only to the peaks and troughs of the roulette raw data and avoid the bridged areas in the middle of the roulette. The best fit partial arcs are shown as full circles (drawn in red) truncated at the center line through the roulette. The radius of the best arc fit is shown in red (in  $\mu\text{m}$ ) near the red cross, which shows the location of the center of the fitted arc. These locations, combined with the arc radii, give a direct measure of the amplitude of the wave form. The peak-to-peak or trough-to-trough distances then define the gauge of the roulette. The individual values provide statistics for the roulette. In this particular example, the gauge using either the peaks or the troughs is 7.78. The average radius for the arcs fit to the peaks is  $670 \pm 38 \mu\text{m}$ , and for the arcs fit to troughs is  $659 \pm 42 \mu\text{m}$ . The average offset for the arc centers from the center line is  $131 \pm 77 \mu\text{m}$  for the peaks, and  $-112 \pm 64 \mu\text{m}$  for the troughs. The average value for the amplitude of the roulette is  $1.57 \pm 0.12 \text{ mm}$ . The HFE calculations applied to these partial arcs give average errors of fit of  $17 \pm 3$  and  $18 \pm 3$  for the upper and lower arcs, respectively. The results cluster into several types described in the literature (Linder and Dromburg, 1983). The author plans to do additional work on the relations of the fingerprints of these roulette patterns.

The same program can analyze the edge profiles of modern U.S. die cut stamps. Figure 10(b) shows the analysis of an edge from the 2008 John Bardeen stamp. The modern die cut edges are very smooth and the wave-like features are well represented by fits to partial arcs of a circle. In this example the gauge is 10.81, and the average amplitude is  $700 \pm 11 \mu\text{m}$ . The average radius for the arcs fit to the peaks is  $459 \pm 8 \mu\text{m}$ , and  $443 \pm 8 \mu\text{m}$  for the arcs fit to the troughs. The average offset for the arc centers from the center line is  $-111 \pm 13 \mu\text{m}$  for the peaks, and  $90 \pm 12 \mu\text{m}$  for the troughs. Because of the smooth nature of the die cuts, the average HFE values are  $8.7 \pm 1.0$  for the peaks, and  $8.3 \pm 0.5$  for the troughs. The small deviations in the different parameters show that the die cuts are made to excellent precision and can be precisely described. Tests of other U.S. die cut stamps show that there is a large range of these edge profiles.

## CONCLUSIONS

The image analysis of perforations to determine statistical characteristics for an entire sheet of stamps reveals the quality improvement over the history of rotary perforation. Two steps in the improvement are observed, and these correspond with documented advances to achieve smaller tolerances in the machining of perforators. The analysis techniques show large differences between the characteristics of different types of rotary perforation and stroke perforation that were used in U.S. stamp production. The same analysis techniques can be applied to single stamps to detect anomalies that often can be expected with re-perforation. Imperfections in pin spacing which appear repeatedly, such as by stroke perforation, provide a method to fingerprint certain perforations. Also, modified

methods can perform similar analyses of other types of stamp separation. Examples using the same circle-fitting methods, but with partial arcs, demonstrate that roulettes and serpentine die-cuts can also be described in terms of the shapes of their features, their peak-to-trough amplitudes, and their roughness of cut.

## ACKNOWLEDGEMENTS

Thanks to Ken Lawrence for many valuable discussions and review.

## NOTES

1. Examples of modern continuous gauges are the Instanta Gauge (Stanley Gibbons, London, UK), the Precision U.S. Specialty Multi-Gauge (Sonic Imagery Labs, Castro Valley, CA), and the high accuracy BSG gauge no longer in print (1948 Buildings Study Group of the German Philatelic Society, produced by Eastman Kodak, Rochester, NY).

2. An example is the PERFOtronic (Safe Stamp and Coin Supplies, Thunder Bay, Ontario, Canada).

3. Some examples of software to measure perforation gauge are EzPerf (SoftPro 2010 Inc., Sault Ste. Marie, Ontario, Canada), ePerforationGauge (Peter Hek, Castricum, The Netherlands), and PERFOmaster 3000 (Hermann Bux, Adelhhausen, Germany).

4. This study included a block of 120 of the 1862 1 cent Proprietary revenue stamp.

5. A variation of the use of 1-way perforators was to automate the work flow between two perforators so that a sheet travels at 90 degrees from the first machine to then perforate it in the second direction. This combination of perforators and work flow, termed an "L" perforator, produced the 1957 4c "Flag Issue," for example.

6. There is a conflicting date in the accounts which cites 1979 for one of the members joining a research group in the project, but perhaps this member was not a part of the initial pilot effort. There are also factual conflicts in the descriptions of the same events from the two different references. Both references rely on personal interviews and recollections of the events.

7. My investigations of effective hole size by machining punches using replacement perforator pins shows that holes tend to slightly smaller sizes than the pin size, by about 1-4% depending on factors such as the stiffness of the paper and the clearance of the pin in the hole. Small clearances and stiff paper result in hole sizes closer to the pin size. Soft paper or large clearances appear to allow stretching of the paper before the pin bursts through the paper, and the relaxation of the paper results in a smaller effective hole size (Mustacich, 2015).

8. The size of pins examined in some early manual stroke perforators made in the U.S., such as by the Rosback Co., measure 0.0395 inches in diameter (1.00 mm), and these measurements match exactly the measurements of replacement pins supplied by Rosback for these early perforators. These old machines also punch holes undersized by 1-4% depending on how they are used (Mustacich, 2015). Other Rosback Co. product pin sizes are also known to exist such as modern philatelic



labels perforated on Rosback equipment with  $\sim 1.10$  mm radius (The Olathe Poste, Olathe, CO).

9. Current specifications for WS 90-V, WS 90-H, and WS 90-VA perforators (WISTA GmbH, Schwaigern, Germany).

10. The NodeXL software extension to Microsoft Excel was used for the network graphing. NodeXL is a product of The Social Media Research Foundation, [www.nodexl.codeplex.com](http://www.nodexl.codeplex.com), NodeXL Excel Template, version 1.0.1.245, June 19, 2013.

11. The literature descriptions of roulette features have confusing uses of the terms height, width, length, etc. Descriptions of roulettes and similar shapes in philately would be more consistent if philatelists adopted the modern terms used to describe the basic features of waveforms.

## REFERENCES

- Bergstrom, R. P. 1984. Drilling Precision Stamp Cylinders at the NBS. *Manufacturing Engineering* **92** (4): 76-79.
- Coope, I. 1993. Circle fitting by Linear and Nonlinear Least Squares. *J. Optimization Theory and Applications* **76**: 381-388.
- Hotchner, J. M. 1989. The Perforating of United States Postage Stamps. *The United States Specialist* **60** (6): 288-294.
- Kitson, R. E. 1988. Perforation Varieties on Recent U.S. Issues. *The United States Specialist* **59** (1): 27-34.
- Leavy, J. B. 1918. Fake Perforations. *The Philatelic Gazette*, May: 154-155.
- Linder, L., and Dromberg, D. A. 1983. *The Serpentine Rouletted Stamps of Finland Issues of 1860 and 1866*. Translation from *The Handbook of Finnish Stamps*. The Scandinavian Philatelic Foundation, Thousand Oaks, CA. p. 30.
- Mustacich, R. 2014. Freak or Fake? A New Fingerprinting Method for Distinguishing between Original and Fraudulent Extra Perforation of 19<sup>th</sup> Century Revenue Stamps. *The American Revenuer* **67** (1): 2-19.
- Mustacich, R. 2015. Fake Perforations on 19th Century U.S. Revenue Stamps: A Stroke of Luck. *The American Revenuer* **68** (4): 2-8.
- Myall, D.G.A. 2003. *The complete Deegam Machin handbook*, 3rd ed. Bridport, Dorset, England, p. C7-5.
- National Institute of Standards and Technology, 2001. *Automating the Future, A History of the Automated Manufacturing Research Facility 1980-1995*. NIST Special Publication 967. National Institute of Standard and Technology, Gaithersburg, MD.
- U.S. Bureau of Engraving and Printing, 2013a. U.S. Dept. of the Treasury. Reprinted private communication dated July 4, 1964, original recipient redacted.
- U.S. Bureau of Engraving and Printing, 2013b. U.S. Dept. of the Treasury. Keeping Holes in Line for the Bureau of Engraving and Printing. A communication to the BEP from Mr. Baker of Harris Seybold Co. dated October 23, 1951.
- Weiss, L. S. 1994. Perforation Measurement and Scott #544. In *Perforation Measurements of United States Stamps*, Bureau Issues Association, Inc., Reprint Series No. 2, Bellevue, IL, pp. 6-13.
- Williams, L. N., and Williams, M. 1971. *Fundamentals of Philately*. American Philatelic Society, State College, PA, pp. 514, 536, 540.



# Shade Verifications Using Tonal Histogram Analyses

*Tim Lyerla*

---

**ABSTRACT.** Distinguishing among possible shades of a given issue can be a vexing problem for the amateur collector, especially if one of the shades is a rare item and more expensive than the others.

Development of a method that is readily available to the average collector and can distinguish the shades of stamps objectively without the aid of color guides has long been a goal of serious collectors.

This investigation examined the expected two different shades of the 1905 issue of German Offices in Turkey 3 Mark value, Michel Germany Specialized Catalog numbers 34a (dark vermillion in UV) and 34b (red orange in UV). The shades were compared using simple visual comparisons of shapes and distributions of red-green-blue channeled pixels for tonal histograms of each item. The results to be discussed verify the use of the method to distinguish 34b as red orange in UV, and different from 34a, but cast doubt on the “dark vermillion” descriptor for 34a.

Computer analysis of the tonal qualities of digital photographs can be done with common equipment, is non-invasive, and an objective method for determining stamp shades. With continuous development, it should provide reliable and repeatable evidence for these determinations.

## INTRODUCTION

My collecting interests are in the German Colonies and Foreign Post Offices. These had a relatively short history from the end of the nineteenth century to the beginning of the twentieth as WWI began—a span of a little more than 40 years. This brevity and the strength of the area in terms of its popularity led to the thought, however naïve, that one might be able to reach some sense of completion for a collection of its basic stamps, as they are limited in number and no longer being produced.

The number of the stamps thought to have been used in these areas has not remained fixed, but grown over the years mainly due to the recognition that more shades of certain issues were available in these areas than previously thought. These are listed as they become known in the Michel Germany Specialized catalog<sup>1</sup> the standard reference for collectors of German stamps. In order to include them in one’s collection with confidence though, they have to be identified, and this is not straightforward. That is, the description of a particular shade can mean different things to different observers, and reliance upon experts, who presumably learn to identify these shades through years of practice, is not always possible. Also, this practice apparently entails comparisons of unidentified items with known samples, which is a purely subjective method and provides no physical evidence for the experts’ determinations.



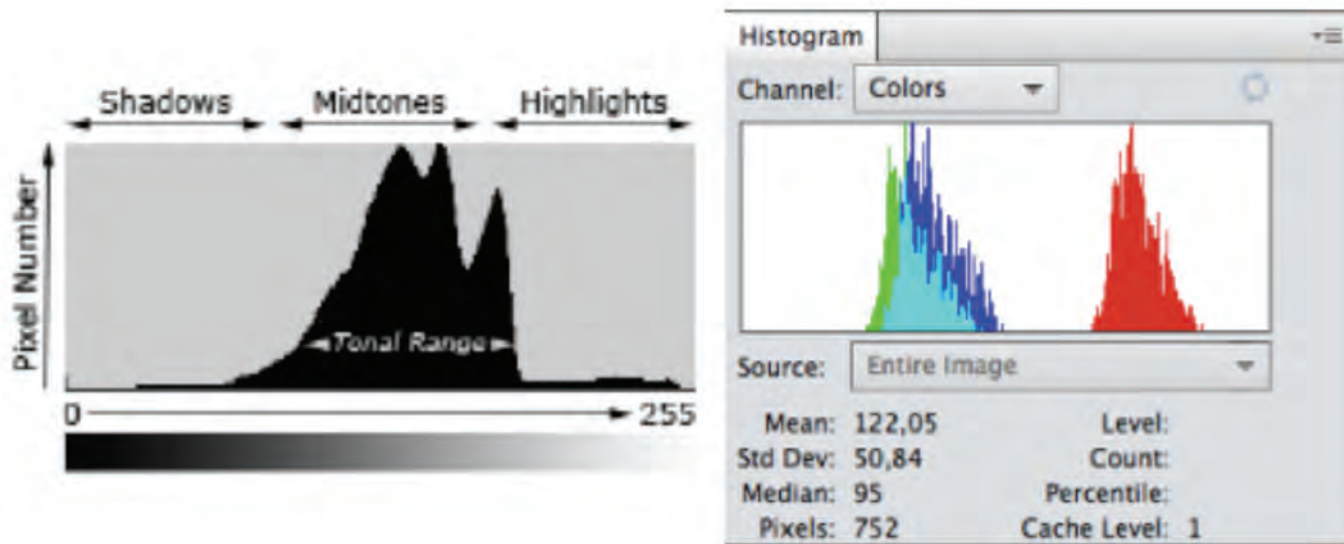

FIGURE 1. Tonal histogram patterns. On the left, a textbook example showing the range of luminance's from 0 (black) to 255 (white) in a digital photograph of 8 bits. On the right, the tonal histogram pattern from a selected region of a stamp illuminated with UV light in the “Colors” channel. Some quantitative information about the histogram is seen in the lower region; however, in this study, only the shape and pattern of the histogram itself are considered.



FIGURE 2. The unveiling of the Kaiser Wilhelm I monument, Berlin. German Offices in Turkey-1905. On the left, Michel Number 34b in visible light (black (brown) violet); on the right its red orange shade in UV.

These issues led to the notion that digital photography might provide a means to distinguish different shades of a given issue, as this method gives tonal histograms--that is, two-dimensional graphic representations of the red-green-blue pixels of an 8-bit image (Photoshop). The graphs have 256 “bins” ( $2^8$ ) along the x-axis that show the brightness (luminance) of the RGB pixels from zero at the origin (black) to 255 at the right end (pure white), with the numbers of pixels at each level along the y-axis (Fig. 1). When a large number of pixels is sampled, the resulting histogram can show filled-in curves of the three additive colors and their regions of overlaps with the subtractive

colors--yellow, cyan, and magenta. A gray area appears where all six colors overlap. It was reasoned that if two stamps of the same issue were truly of different shades, their tonal histograms should be distinctly different as well, and would provide some physical evidence to support this distinction.

The stamps used for the analyses presented here are from the German Empire issue of 1900 and overprinted for use in the Offices in Turkey. The entire set from which they are members is commonly known as “Representative Depictions of the German Empire.” The stamp of interest is the 3 Mark large format depicting the unveiling of the Kaiser Wilhelm I

monument in Berlin (Fig. 2). Its first use in Turkey is listed in the Michel Germany Specialized catalog as numbers 21I and 21II, with varieties in engraving but not in shades. In October of 1905, the stamp was re-designed to read “Deutsches Reich” instead of “Reichpost”, and now said to exhibit two shade varieties--34a as dark vermillion in UV light, and 34b as red orange in UV light, but no difference in shade under visible light (black or brown violet). Later, the stamp was re-issued again, this time on watermarked paper, and listed as two varieties--46a as red orange in UV light, and 46b as non-reactive in UV light; but this time with a difference in visible light: black(gray)violet vs. black brown violet.

The focus of the investigation was to attempt to distinguish 34a from 34b shade varieties using tonal histograms. This was because the “a” variety is listed in Michel is worth almost 10 times that of the “b” variety in all of its permutations (mint, mint unhinged, and used), and essentially unknown on cover. It was thought useful, then, to have a reliable, independent method to verify that the higher price usually paid for the rarer 34a item was justified.

## MATERIALS AND METHODS

The camera used for taking UV photographs is a Panasonic “Lumix” DMC-G5 equipped with a Canon 100mm telephoto lens for close-ups, a Kenke 52 mm UV filter and remote shutter release (Fig. 3). It is set at f11, the camera’s Aperture mode (for automatic shutter speed and ISO), and 10000 K color temperature. Two 40-watt long wave (365nm) UV lamps are used to completely illuminate the item, which is set on a black background. The camera is mounted on a Promaster XC522 tripod, which allows for it to be removed and replaced in the same position as often as needed. All pictures are taken in a completely darkened room. A 64 GB memory card captures the images, which are then transferred to the computer for analyses using Adobe Photoshop Elements (v. 11 for these studies).

Photoshop can be used in three different modes - Quick, Guided, and Expert. The Expert mode was used for this study (Fig 4). The main menu for manipulating photographs is found in the blue top line, and the command to Open a file is on a second line to the left of the screen. When this is pressed with the cursor, it asks for a photo file to be placed in the window (Fig. 5) which, for these analyses, is in JPEG format. The files are loaded in a size that can be accommodated in the window, and were enlarged to 50% in this study using the magnification tool for ease of sampling different areas of interest for their tonal histograms (Fig. 6). When a selection is made, either with the circle or square selection tool, the tonal histogram for this region can be accessed from the Window command of the menu line (Fig. 7).

## RESULTS

The samples of tonal histograms (Fig. 8) are all from the stamp shown in figure 1 and exhibit a range of variation that can be found with this “water drop” technique using either the square or circle selection tool. There are differences among



FIGURE 3. Set-up for UV photographs. The camera is mounted on a tripod and focused on a stamp located on a black background between two 40-watt UV (365 nm) lamps. Exposure is made with a remote shutter seen lying against the right-most leg of the tripod.

these, but all are the same basic type. The RGB pixels form a continuous unit along the x-axis and overlap in about the same manner. Red pixels have the highest luminance and form the rightmost slope or region of the continuum. Green pixels have the lowest luminance, with the blue pixels slightly higher and immediately adjacent to form an extensive cyan region of overlap that makes its own curve. There is a usually variable region of overlap between the blue and red pixels that yields a magenta color. A few pixels exhibit the yellow color where green and red pixels overlap. The extent of these overlaps determines the size of the gray area in the middle of the continuum, where all six colors are to be found.

The variations in this basic pattern are due to the inhomogeneity of the shade in each of the samples. There are varying levels of whitish areas and densities of color that contribute mainly to an extension of the red rightmost area toward a higher luminance. There is a good correlation between the

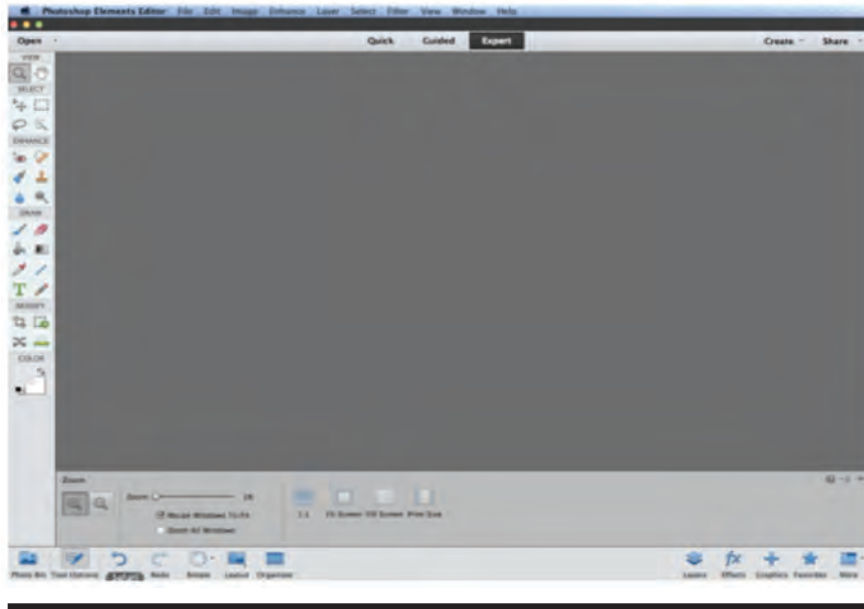

FIGURE 4. Adobe Photoshop Elements window for opening photographs in the Expert mode. Commands for handling the photograph are in the blue space at the top of the window, while tools for manipulating regions within the object are shown on left and bottom of the window.



FIGURE 5. A stamp of interest opened in the window of a Photoshop page at 16.7% original size. Information about the item from its source is seen in the white box at the upper left corner and outside the gray background of the window.



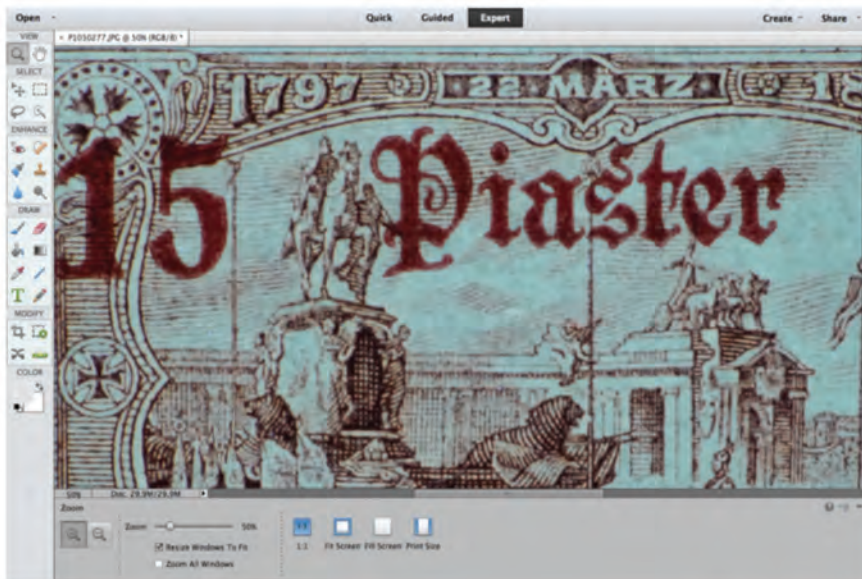

FIGURE 6. The stamp in figure 5 enlarged to 50% original size using the magnification tool seen as activated (gray background) in the upper left region of the toolbox, and in positive mode in its symbol at the left end of the bottom region tool box.

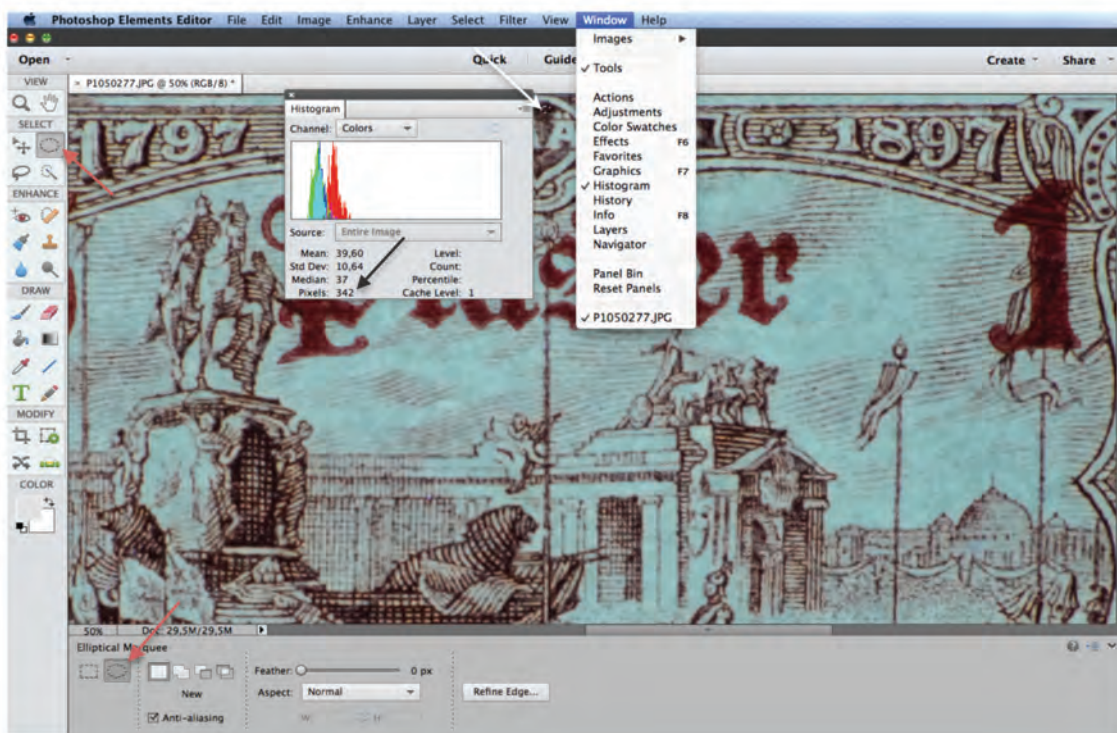

FIGURE 7. Tonal histogram pattern of the small region of the shade selected (white arrow) containing 342 pixels (black arrow). Note that the circular selection tool in the right column of the toolbox and bottom left region is in active mode (red arrows).

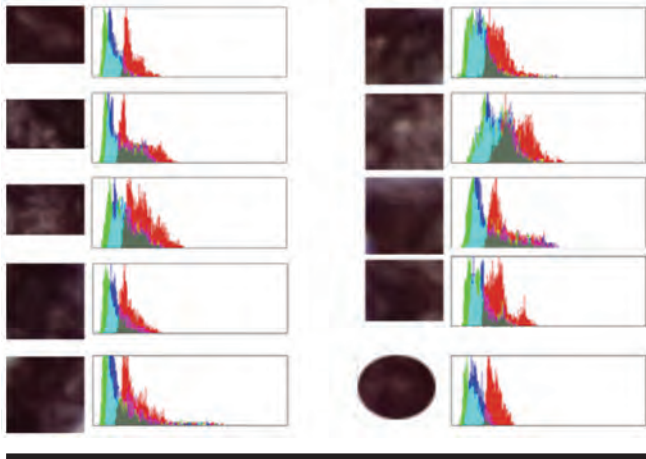

FIGURE 8. Tonal histogram patterns from various regions selected in the stamp shown in figure 7. The most representative of the basic pattern is seen in the upper left or lower right results. The others exhibit variations of this pattern that are due to the amount of flecking in these samples and can be attributed to in-homogeneities of the printing process.

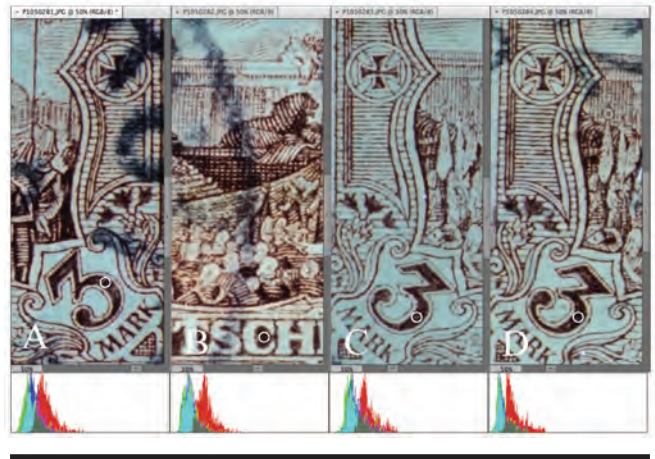

FIGURE 10. 34b: Michel Offices in Turkey number 34 stamps exhibiting red orange in UV tonal histograms from “water drop” selections (white circles; see Fig. 9) of the right (A) or left (C and D) postal values or the “Deutsches Reich” inscription (B). A: item sold as 34a.



FIGURE 9. 34b: Michel Offices in Turkey number 34 stamps exhibiting red orange in UV tonal histograms from “water drop” selections (white circles indicate approximate sites) of the left postal values. Numbers of selected pixels ranged from around 350 to 750 for all samples. B: item sold as 34a. C: item signed 34b.

amounts of less dense areas observed in each sample with the level of extension toward the high luminosity of the histogram. For this reason, the curves exhibiting the least amount of this “noise” are considered most representative of the tonal histogram for a given shade and used for purposes of comparisons among the stamps investigated. For this stamp, these would be the histograms seen in the upper left (square) or lower right (circle) samples considered as indicative of the red orange shade in UV.

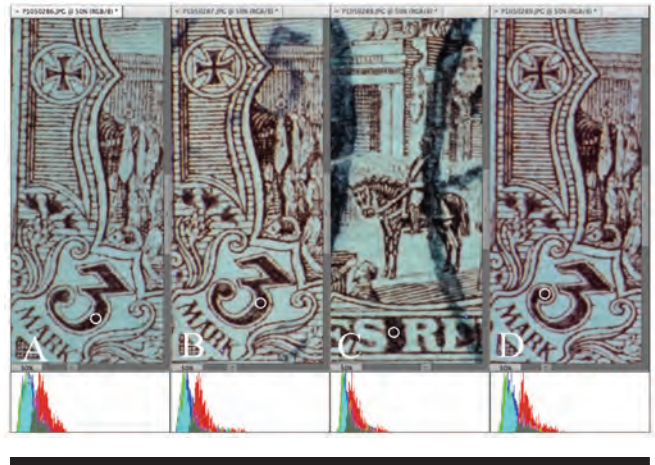

FIGURE 11. 34b: Michel Offices in Turkey number 34 stamps exhibiting red orange in UV tonal histograms from “water drop” selections (white circles; see Fig. 9) of the left postal values (A, B, and D) or the “Deutsches Reich” inscription (C). B: item signed “b”. C: item expertized as 34a.

A total of eighteen different German Offices in Turkey, Michel Germany Specialized catalog number 34 stamps were analyzed. These are simple to identify as the 3 Mark large format stamps, un-watermarked, and inscribed “Deutsches Reich”, not “Reichpost”. The stamps are shown in figures 9 to 13. The numeral “3” denoting the 3 M postal value was used most often for the representative tonal histogram. The figures not showing the “3” indicate the area used for that item.

All of the stamps shown in figures 9 through 12 have tonal histograms that are associated with the red orange shade of Michel number 34b. One shown in figure 9B was sold as 34a,



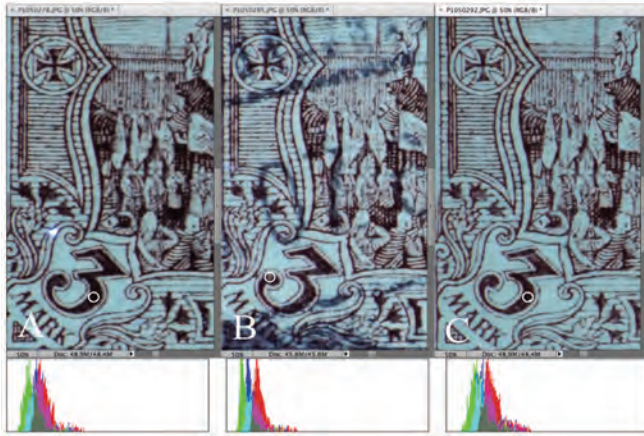

FIGURE 12. 34b: Michel Offices in Turkey number 34 stamps exhibiting red orange in UV tonal histograms from “water drop” selections (white circles; see Fig. 9) of the left postal values. B and C: items signed “b”.

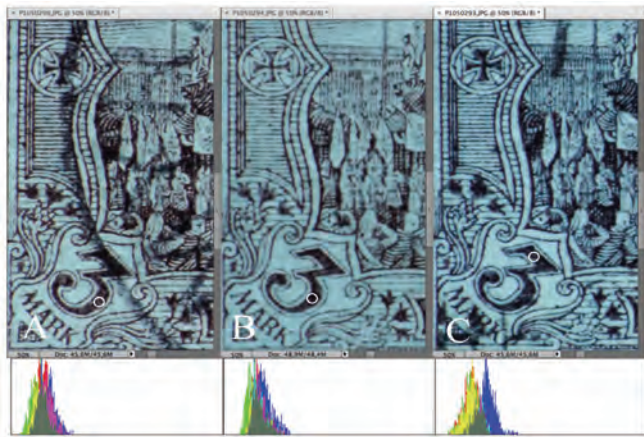

FIGURE 13. 34a: Michel Offices in Turkey number 34 stamps exhibiting tonal histograms with highest luminance in the blue channel from “water drop” selections of the left postal values, presumably “dark vermillion” in shade. A and B: signed “a”. C: expertized as 34a and 34b.

while 9C was signed with the letter “b”. The other two stamps were purchased without any designation. Three of the items in figure 10 were also purchased without designation, while the stamp in 10C was signed “b”. In figure 11, B was signed “b” and C was expertized as 34a. In figure 12, two of the three stamps were signed as type “b”.

The last three items of the eighteen investigated are shown in figure 13, all are Michel number 34, and all share the property of exhibiting tonal histograms that do not match those seen with the high red luminance of Michel number 34b. Two of these, figure 13A and B, are signed as type “a”. In their

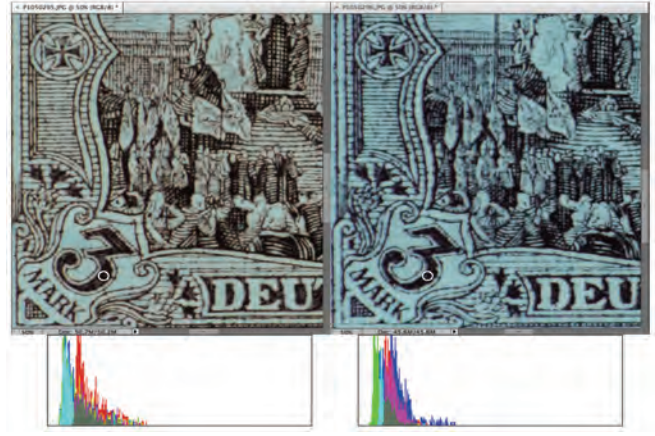

FIGURE 14. Tonal histograms from “water drop” samples (white circles; see Fig. 9) of the left postal numerals of stamps from the German Offices in Turkey, Michel number 46, the watermarked variety of number 34. On the left is 46a, red orange in shade in UV, and on the right, 46b, non-reactive in UV. Note the similarities of the tonal histograms seen in figure 13 with that seen here for the non-reactive in UV shade.

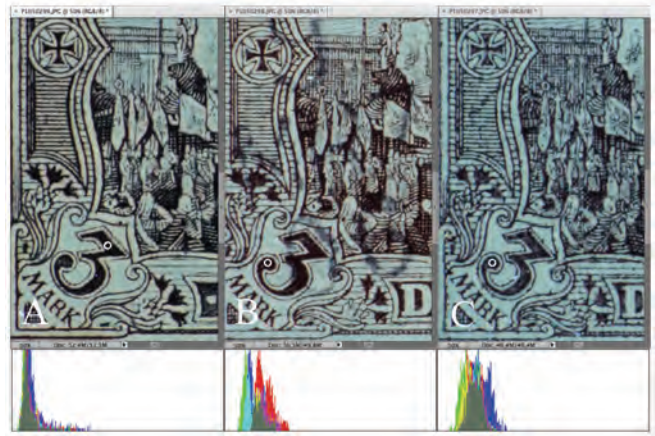

FIGURE 15. Empire issues of the 3 M large format stamp showing unveiling of the monument to Kaiser Wilhelm I in Berlin. Tonal histograms were taken as “water drop” selections (white circles; see Fig. 9) from the left postal numerals. Designations for the shades are as follows: A=Michel number 65I, non-reactive in UV; B=Michel number 96AIa, red orange in UV; C=Michel number 96BII(b?), non-reactive in UV. Items A and B appear somewhat similar in shade, but have distinct tonal histograms.

tonal histograms, the blue pixels have the highest luminance and form the right edge of the continuum. The stamp shown in Fig. 13C is unique, as it has been expertized, with photo attests, as 34a and 34b. Its tonal histogram has the highest blue luminance recorded among all of the Michel number 34 stamps used for this investigation.



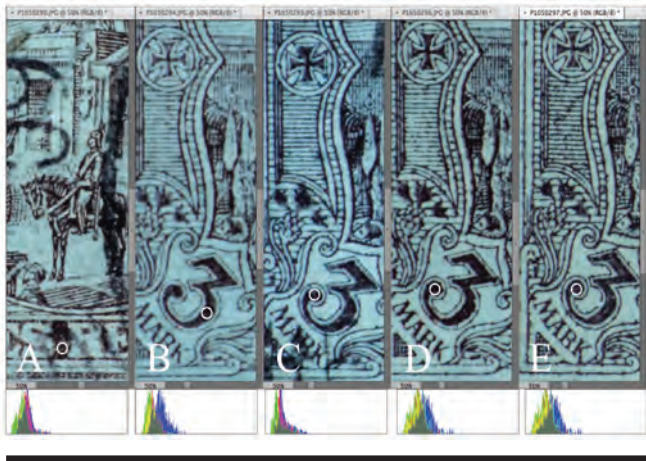

FIGURE 16. Side-by-side comparisons of tonal histograms made from “water drop” selections (white circles; see Fig. 9) of stamps presumably “dark vermillion” in UV (A-C, as in figure 13) or non-reactive in UV (D and E, as in figure 15A and 15C). A and B—signed as “a”; C—Expertized as 34a and 34b. All of these tonal histograms, unlike those for stamps of this issue exhibiting red orange in UV, show highest luminance in the blue channel (right edge of the histogram) in varying degrees of prominence.

These results are compared with the tonal histograms seen in the watermarked variety of this stamp. These are Michel number 46 in the Offices in Turkey, listed as 46a-red orange in UV and 46b-non-reactive in UV. Their tonal histograms are shown in figure 14.

The only 3 Mark stamps from the Empire available for this study are given in figure 15 and again, have tonal histograms from UV illuminated photos that show the red orange vs. non-reactive patterns. The first issue with the “Reichpost” inscription is Figure 15A, and is classified as non-reactive in UV as it is listed only as brown black to violet black in shade in visible light. The Michel number 96 varieties with “Deutsches Reich” inscription are listed as having a red orange in UV shade, shown in figure 14B. Its counterpart with no indication of a UV shade in figure 14C.

For ease of comparison, the five stamps listed as either “dark vermillion” or non-reactive in UV are shown in figure 16 along with their tonal histograms. These share a common difference from the tonal histograms of stamps exhibiting a red orange shade in UV, as blue now exhibits the highest luminance with red overlapping (Fig. 16 A, B, and D) or more distantly lower (Fig. 16 C and E). However, there is no obvious distinction separating these into two groups, as the same types of

histograms are seen in both the supposedly “dark vermillion” shade of the Offices in Turkey Michel number 34 issue and in the UV non-reactive shade of other issues.

## DISCUSSION

The results of this investigation indicate that there is a typical tonal histogram pattern for the red orange shade in UV of the 3 Mark large format stamp from Germany issued in the late nineteenth and early twentieth centuries celebrating the unveiling of a monument to Kaiser Wilhelm I in Berlin. The stamp is listed in Michel Germany Specialized catalog for the Offices in Turkey “Deutsches Reich” inscribed, unwatermarked item (Michel number 34) as having two shade varieties—red orange in UV (34b) and dark vermillion (34a).

Any Offices in Turkey Michel number 34 stamp, then, possessing the typical tonal histogram pattern for red orange in UV and classified as dark vermillion would be in error. Of the fifteen stamps used in this study having this pattern, one was signed “a” and another expertized as 34a. This yields an error rate of 13% (2 out of 15), which seems high given the ease of proper identification using tonal histograms. There is a premium to be paid for Michel number 34a variety, as it is the rarer of the two, which gives a justifiable reason for collectors to expect this error rate to be zero. The tonal histogram provides a form of independent evidence for the determination of the red orange shade of this stamp—something to be considered by collectors when they purchase a presumed 34a variety. That is, it should not exhibit this tonal histogram pattern.

The results of this investigation, however, did not yield a typical tonal histogram pattern for the “dark vermillion” shade. Of the eighteen Michel number 34 stamps studied, three did not have the red orange in UV tonal histograms, but neither did they have their own histogram type. The histograms seen for these non-red orange items could not be distinguished using simple visual comparisons from those derived from this stamp cataloged as non-reactive in UV.

Importantly, the rarity of the non-red orange in UV type for this issue was verified in this study. Only three of the eighteen samples, or around 17%, were found. This gives confidence in the method described here to distinguish Michel number 34a from 34b in the German Offices in Turkey stamps.

## NOTES

1. *Michel-Deutschland-Spezial 2014*. Vol. 1: 1849 to 1945. Schwaneberger Verlag, GMBH, Unterscheißheim, 1150 pp.

# The “Rosette Eagles” of Mexico - Microscopic Analysis of Paper Content of Mystery Mexican Stamps Confirms Origin and Date

*Farley P. Katz*

---

**ABSTRACT.** The Rosette Eagle stamps of Mexico have been known for over 100 years but are of uncertain status. Evidence suggested that plates for the Rosettes had been engraved in 1863 as a planned issue of Mexican stamps, but that the stamps were not printed until many years later by stamp dealers who had obtained original plates of the 1856-1861 Hidalgo stamps of Mexico which they used to manufacture private reprints. The texture of the paper was examined and found to be unlike any of early Mexican stamps but closely similar to that of the reprints. Microscopic fiber analysis was conducted of a variety of Mexican stamps from 1856 to 1894, samples of the Rosette Eagles, and reprints. All Mexican stamps tested from 1856 to the early 1880s were made entirely of rag paper with cotton and flax fibers. Grass fibers such as wheat and softwood fibers did not appear until the 1880s. The Rosette Eagles’ paper was found to be made entirely of softwood and grass fibers, with no rag content. Several reprints of the early Hidalgo stamps were tested and found to have fiber content very similar to the Rosettes. This analysis confirmed the Rosette Eagles were not printed in the 1860s, but rather years later, likely by the persons who made the reprints.

## **SUMMARY OF THE PROBLEM<sup>1</sup>**

The Rosette Eagle stamps are engraved in intaglio and exist in two values, one real and two reales, both imperforate (Figures 1-2). Their design and colors are close to those on the 1864-1866 Eagle stamps of Maximilian’s Mexican Empire, and are obviously related to those stamps (Figure 3). Like the Eagles, they have a central oval with the eagle, cactus and snake, but unlike them, the Rosette eagle has no crown. They have engine-turned rosettes in the corners, which gave them their name. Some blocks are known in which the stamps have a highly irregular orientation like that of the Eagle stamps.

The stamps are denominated in reales, a currency scheduled to be abandoned by Mexico on January 1, 1862, but actually continued in use until the three-centavo Eagle of May 1, 1865. Although the stamps appear to date to the 1860s, they are entirely unknown in philatelic literature until 1908.<sup>2</sup> Since the stamps are relatively common today, this fact suggests they did not exist prior to about 1908.

The Rosettes have always been a mystery. They have been stated to be genuine stamps pre-dating the Eagles, essays for the Eagles, facsimiles made by Mexico for exhibition at the 1893 Chicago World’s Fair, or outright fakes or fantasies. The fact the stamps are finely engraved in intaglio makes it unlikely they are fantasies as that method is expensive, time consuming, and rarely used for fakes. The Chicago World’s Fair story also may be dismissed since, if Mexico had desired copies of the stamps, it could have made reasonably accurate copies, not stamps with a different frame and eagle.



FIGURE 1. Rosette one real.



FIGURE 2. Rosette two reales.



FIGURE 3. Eagle 1864-66.

The Rosettes have a connection with a group of stamps known as the “Fraudulent Reprints.” Near the end of the nineteenth century, dealers somehow obtained original plates used to print the 1856-1861 Hidalgo stamps of Mexico. They used those plates to print thousands of copies of the earliest stamps of Mexico to which they added various fraudulent cancellations and district overprints. The reprints “flooded” the market and are still abundant today. Many of the same false cancellations and overprints used on the Reprints are also found on the Rosettes. In addition, two of the earliest philatelists to have published a mention of the Rosettes, Charles Pinon in 1910 and C. H. Mekeel in 1912,<sup>3</sup> are also known or alleged to have been associated with the wholesale distribution of the Reprints.

These facts suggested a possible solution to the Rosettes’ mystery. If the plates for the Rosette stamps had been engraved by the Mexican government before the Eagle stamps, those plates could have remained in its possession. The persons who took the plates for the 1856-1861 issues at the end of the nineteenth century might also have taken the Rosette plates. Those plates could have found their way, along with the Hidalgo plates, to the persons who produced the Fraudulent Reprints and could have been used to manufacture the Rosettes along with the Reprints.

The texture of the paper and its fiber content was investigated to see if they could confirm or disprove this hypothesis.

## THE ROSETTES’ PAPER AND ITS TEXTURE

The Rosettes’ paper is light cream-colored and sufficiently opaque that the design does not show through on the back. The average thickness of the stamps (without gum) is .082 mm. The backs are smooth to the touch. Viewing the stamps under a 30x microscope, there is a highly distinctive texture with many long, curving fibers of varying thickness and length, in random orientation, often intersecting. Viewed under the microscope’s overhead light source, the fibers give the illusion

of being indented, similar to a pattern in the lines in one’s palm (Figure 4). Images shown here were taken with a bright LED light source at an acute angle to the paper, then converted to grayscale.

If the Rosettes had been printed in the 1860s, their paper presumably should resemble that of other stamps of the period. A variety of genuine stamps from the 1856 through the 1872 issues was examined under 30x magnification. None had paper even slightly resembling the Rosettes’ distinctive paper. All had wove paper with thin fibers of short or medium length, which form dense, uniform patterns (Figure 5). Some were a little “furry,” with fibers lifting off the paper.

Although this texture was not seen on early Mexican stamp paper, similar paper occurs in some of the Reprints. A number of examples of the Fraudulent Reprints in the reference collection of the American Philatelic Society were examined. Some of these were lent for further examination. Several of the four reales of 1856 had a closely similar texture, although their paper was very slightly thicker (.085 - .09 mm) than that of the Rosettes (.08 mm) (Figure 6).

Surface texture is a result of several factors, including the degree to which the slurry is beaten. The beating results in the breaking up of clumps of fibers into smaller clumps and individual fibers and even “fibrillation,” or the breakdown, of individual fibers.<sup>4</sup> The distinct texture of the Rosettes and Reprints appears to be attributable to the presence of large clumps of fibers not broken down into individual fibers, like the paper used for the early issues of Mexico.

## PAPER FIBER ANALYSIS

In addition to examination of the texture, the fibers used in the Rosettes’ paper were examined microscopically. Historically, paper was manufactured from rags and consisted mostly of cotton fibers and flax from linen. In the eighteenth century, inventors began to experiment with other sources of fibers. Straw, mostly wheat and rye, was used to make paper as early



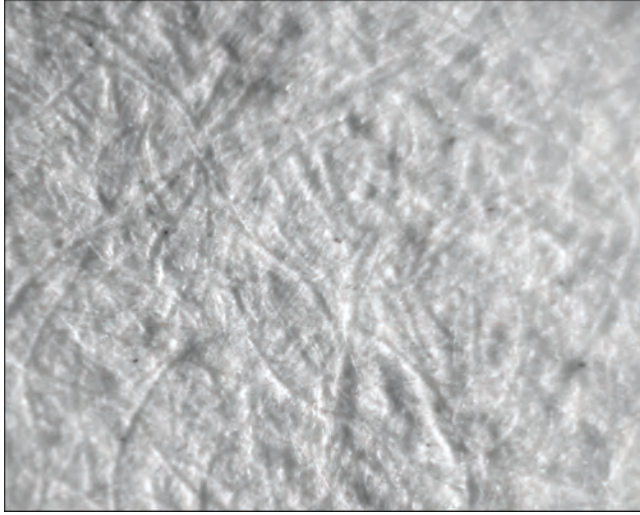

FIGURE 4. Rosette Paper 30x.

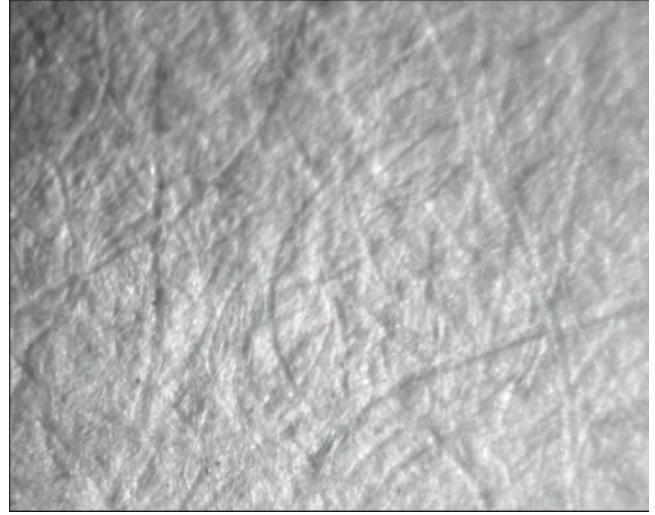

FIGURE 6. Reprint Paper 30x.

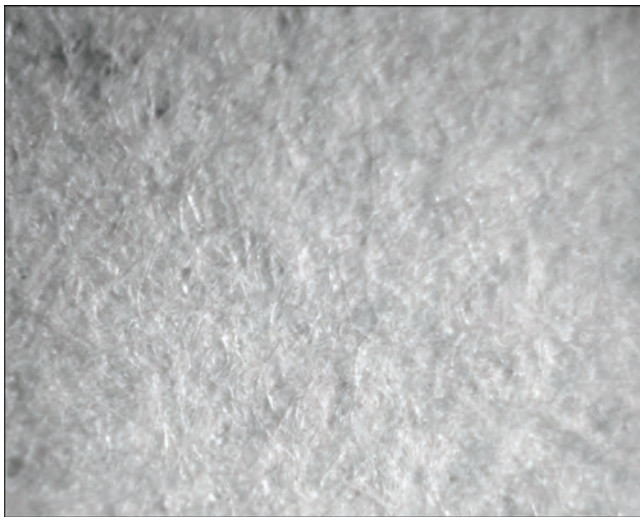

FIGURE 5. 1864 Eagle Paper 30x.

as the eighteenth century and was used in the mid-1800s, mixed with other fibers, primarily to make newsprint and wrapping paper. Quality paper containing wheat straw was still being developed in the 1860s.<sup>5</sup>

Several processes also were invented to make paper from wood fiber. One, “soda wood pulp,” involved boiling wood chips in caustic alkaline soda. This was created in England around 1840 and patented in the United States in 1854. A process of breaking down wood fibers by acid, known as “sulfite pulp,” was developed in the late 1850s, but was not commercialized in the United States until 1882.<sup>6</sup>

Mechanically ground wood pulp was used to make wrapping paper and newsprint as early as the 1840s, but quality paper was not produced commercially until about 1868 in

England and in 1875, in the United States.<sup>7</sup> These dates are not absolutes and it is possible fibers other than rag could be found in earlier paper.<sup>8</sup>

No studies of the paper content of nineteenth century Mexican postage stamps have been published.<sup>9</sup> In fact, little research into the paper fibers of the stamps of any country has been published, with the notable exception of R. H. White’s *The Papers and Gums of United States Postage Stamps, 1847-1909*.<sup>10</sup> White concluded all United States stamps were made from rag paper until the second half of the 1870s, when soda wood pulp mixed with rag/cotton was first introduced.<sup>11</sup>

Although Mexico had paper mills as early as 1575,<sup>12</sup> its technology in the nineteenth century was not as advanced as that of the United States and Europe. In the first half of that century, Mexico produced paper from rags, consisted of linen, cotton and hemp fibers, sometimes with maguey (agave or sisal) or ramie (China grass).<sup>13</sup> In 1863, Mexico reportedly had eight paper mills.<sup>14</sup> In 1867, another report stated there were eight paper mills in the Federal District and the states of Puebla and Jalisco, which used primarily cotton and maguey fibers.<sup>15</sup> By 1882, Mexico had 12 paper mills, but most of the paper produced was of lesser quality and 70% was imported, including most of its high quality paper, from France, Germany, Italy, Spain and the United States.<sup>16</sup>

Rag fibers can be distinguished microscopically from other fibers by morphology and color staining. A number of resources available illustrate fibers found in paper which may permit identification at a species level such as *Fiber Atlas* by Marja-Sisko Ilvessalo-Pfäflí (1995).<sup>17</sup>

There are two manufacturing processes that affect the composition of rag paper. The first process is the initial making of cloth from cotton, flax, or possibly hemp. Cotton is obtained from the cotton bolls on the plant which contain seed hairs, each hair being a single, long cell. The cotton fibers are cleaned of various impurities, including unwanted parts of the plant. Flax is manufactured from the “bast” or inner bark of

the plant which contains long individual fibers. The fibers are separated from the rest of the plant by chemical and mechanical methods. Then the cotton and flax fibers are used to manufacture cloth. The result is that cotton or flax cloth, and in turn, rags, are composed almost entirely of fibers without contamination.

The second process is the conversion of rags into paper. This involves a number of actions, including initial sorting, trimming, repeated washing, retting, bleaching, cooking with caustic soda, and repeated chopping and beating to break down clumps into individual fibers.

Cotton fibers used in paper are typically long, curved, twisted and folded over themselves. Flax fibers are long and thin with a dark central lumen, more angular with numerous transverse cracks and periodic nodes. Due to the repeated processing, it may be difficult to distinguish cotton and flax fibers in paper.

Unlike cotton and flax fibers, where only one type of fiber is used in making paper, more of the plant is used in paper made of grass. Grass fibers used in paper, such as wheat or straw, come in a variety of distinct shapes and sizes including large “parenchyma cells” (ground tissue which look like blunt-ended capsules with tiny irregularly spaced perforations), distinctive serrated epidermal cells, and long, thin, whip-like structural or stem fibers.<sup>18</sup> Wood fibers, in turn, are straighter, broken into shorter pieces, with distinct structures, such as rows of pits or large, regular perforations on softwood fibers, and grids of tiny perforations on hardwood fibers.<sup>19</sup>

There are a number of iodine-based chemical stains that enable one to distinguish between various fibers commonly found in paper such as Graff “C” stain or Herzberg stain. Here, Herzberg stain was employed. Cotton fiber appears as “brilliant purplish pink to vivid red purple” in Herzberg stain. Chemical softwood fiber, however, shows different colors depending on whether the pulp was bleached. If bleached, it appears “dark purplish gray to dark reddish purple,” but, if unbleached, it is “dark bluish gray to weak purplish blue.”<sup>20</sup>

Sample stamps were first soaked in distilled water to remove hinges or paper adhesions. Stamps were cut in half and one half was cut into little pieces and the fragments were boiled in distilled water for 1.5 hours or longer to break the paper down. The paper fragments were transferred to a test tube with distilled water, to which glass beads were added for abrasion. The test tubes were shaken until the water became cloudy through release of fibers. A few drops of the solution were placed on a microscope slide and the water evaporated on a hotplate. After the slide cooled, a drop of Herzberg stain was added before putting on a slide cover. The slides were examined under 100x and 400x magnification using an OMAX 40x-2000x compound biological microscope with a built-in 2.0mp USB digital camera. Then digital images were made.

Nineteen Mexican stamps from 1856 to 1895 were examined. All early stamps, through about 1880, were made entirely of rag paper, primarily cotton with some flax fibers. The fibers from a one-real 1861 Hidalgo (NF7<sup>21</sup>) were long and thin with some twisting, broken ends and no internal structure, and were rag fiber (Figure 7). The color was intense reddish purple, indicating cotton. The fibers from a one-real 1856 Hidalgo (NF3) were very similar, as were those from a first period 1864 Eagle (NF19), two 1866 Maximilians (NF49 and NF55A), an 1868 Hidalgo (NF70), an 1872 Hidalgo (NF89), Hidalgo “Bank



FIGURE 7. 1861 stamp rag fibers 100x.

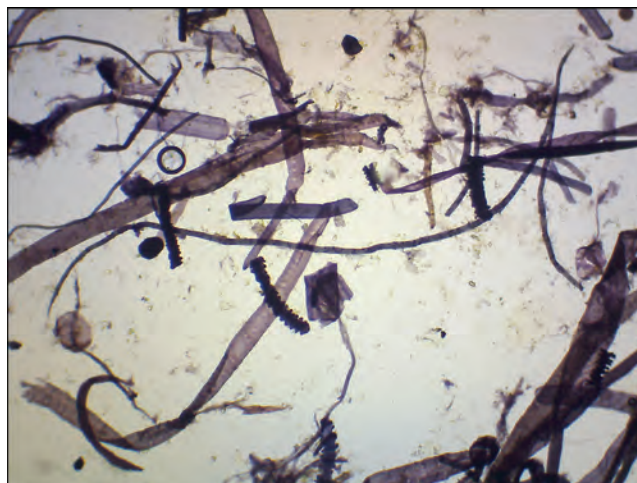

FIGURE 8. Rosette fibers 100x.

Notes” dated 1876 (NF99z), 1877 (NF98yy), and 1882 (NF 110), and a Mail Transport of 1895 (NF202). A Fourth Period Eagle of 1865 (NF37) contained cotton fibers but also a larger percentage of flax fibers.

The earliest grass/straw fibers found were in an 1880 dated “Bank Note” (NF111y) consisting of a distinctive epidermal cell. In Herzberg stain, grass epidermals appear intensely dark. Similar fibers were also in a Foreign Mail issue overprinted 1882 (NF122y or z), an 1884 Hidalgo Medallion (NF143), an 1886 Numeral (NF166), and an 1887 Hidalgo Medallion Official (NFO3).

The earliest stamp found to contain softwood fibers was an Hidalgo “Bank Note”, dated 1883 (NF111), which contained hardwood fibers, some softwood, and rag. An 1894-1895 Large Numeral (NF189yy) had a variety of fibers, mostly softwood, with a few epidermal cells from straw, and a number of bright yellow irregular fragments, which could be lignin.



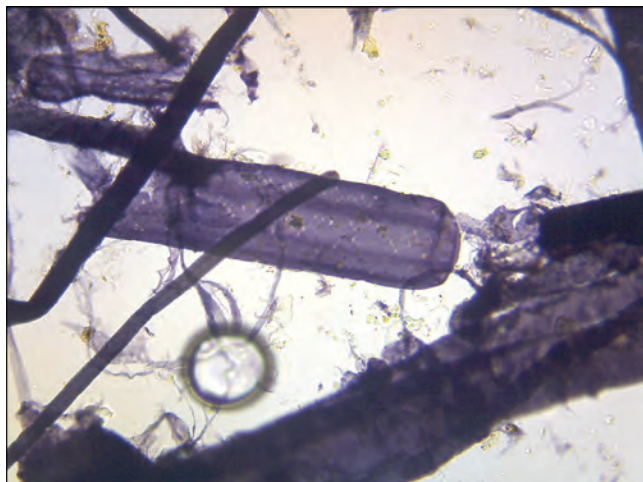

FIGURE 9. Rosette parenchyma 400x.



FIGURE 11. Reprint fibers 100x.

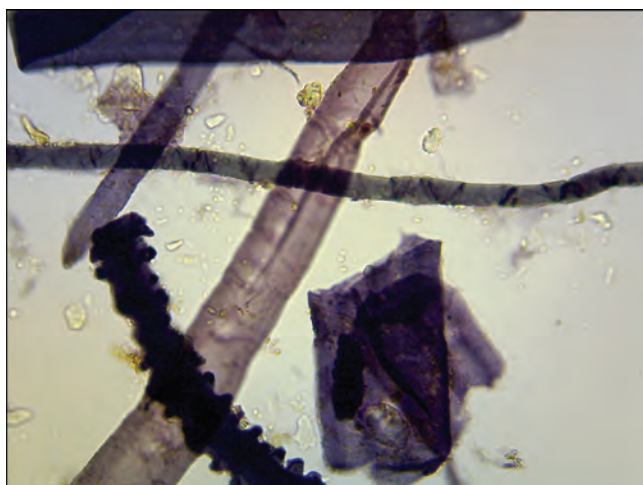

FIGURE 10. Rosette epidermal and wood cells 400x.

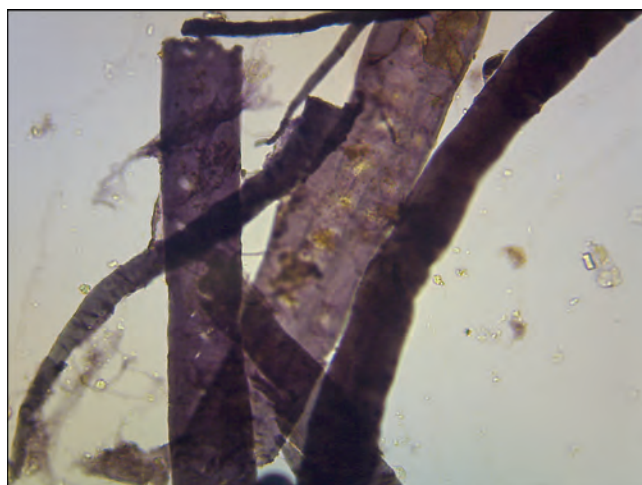

FIGURE 12. Reprint softwood 400x.

The Mexican stamps tested did not have grass or softwood fibers before the 1880s. This is consistent with the secondary literature discussed above, and White's analysis of United States stamp paper, stating that soda wood pulp was first introduced in the second half of 1870s and pure wood pulp paper was not used until the early 1890s.

A one-real Rosette was examined. It had a variety of fibers of different shapes and thicknesses (Figures 8-10), of which many of the fibers were large, with distinct patterns of large, external pits, diagnostic of conifer wood fibers.<sup>22</sup> There were also many cell types typical of a grass, including abundant large parenchyma cells, distinct serrated epidermal cells, and long thin, curving fibers. These were from straw, perhaps wheat.<sup>23</sup> The fibers with the conifer pits were stained light to medium reddish purple, indicative of bleached chemical wood. The epidermal cells were darkly stained. Some fibers were various shades of red-purple and their morphology was used to distinguish them.

None of the fibers, however, was rag. A second Rosette tested had the same fiber content.

The Rosette's paper contained no cotton or flax, and was composed entirely of grass and softwood fibers. No such paper appears to have existed commercially in the 1860s, and was unlike anything Mexico used for stamps through the end of the nineteenth century.

A four-reales Fraudulent Reprint with a Monterrey district overprint was tested. The fibers present were the same as in the Rosettes: conifer fibers with large parallel perforations and grass cells including parenchyma cells and serrated epidermal cells (Figures 11-14). The fibers were so similar to those of the Rosettes that the paper may be identical. Two more eight real Reprints were tested, one "unused" and the other with a Minatitlan cancellation which also appears on Rosettes. They had closely similar fibers.

To confirm these results, three samples were sent for analysis to John D. Hankey, a paper fiber expert in Appleton,





FIGURE 13. Reprint parenchyma 400x.



FIGURE 14. Reprint epidermal cell 400x.

Wisconsin. Mr. Hankey determined that a NF3 sample consisted of 91 percent cotton fiber, 9 percent flax, and a NF37 64 percent cotton and 36 percent flax. Both were pure rag paper; neither contained any wood or grass fibers. The Rosette, however, was 61 percent bleached straw fibers and 39 percent bleached softwood fibers. The grass fibers “possibly” were wheat and the wood fibers spruce (95 percent or more) and other softwoods.<sup>24</sup>

Paper composed of 61 percent straw and 39 percent softwood appears to be an unusual combination with an exceptionally high percentage of grass, at least prior to 1900. The W. J. Barrow Research Laboratory study of paper used in books printed from 1800 to 1899 found no paper composed exclusively of grass and softwood fibers. The earliest records for paper composed entirely of grass with any percentage of wood was 1872. The highest grass content used with any other fibers was 40 percent (1873).<sup>25</sup>

## CONCLUSION

Evidence suggested the Rosette Eagles had been engraved in 1863 to replace the 1861 Hidalgo stamps, but had, in fact, been printed years later from the original plates by persons who used original plates to produce the Fraudulent Reprints.

Comparison of paper texture supports this hypothesis. The Rosettes have a distinct texture of large, curving fibers. This texture is unlike any of the early stamps of Mexico which have a uniform, featureless texture, but closely resembles that of several Fraudulent Reprints examined.

Microscopic examination of the fiber content in these stamps also supports these conclusions and confirms the Rosettes could not have been printed until the late nineteenth century. All early stamps of Mexico until the 1880s were made exclusively of rag paper. The Rosettes, however, were made entirely of grass and softwood fibers, a paper that did not exist in the early 1860s. The paper of the Fraudulent Reprints, known to have been printed no earlier than about 1893, was very similar to that of the Rosettes.

Although fiber analysis requires destruction of the stamps involved, provided the stamps in question are inexpensive, that is not a problem. Most of the stamps tested were very common or damaged, and had little or no value. Despite its relative simplicity and low cost, fiber analysis has seen little use in philately. This is unfortunate, as it is a powerful tool for providing information on the nature of stamps and for solving philatelic mysteries especially the dating of stamps. It would be informative to prepare comprehensive surveys of fiber content by country and period, every five or ten years. It may be possible to determine the geographic source of the paper used by identification of species of wood. These lines of research would be of value to industrial and economic history as well as philately.

## ACKNOWLEDGEMENTS

In addition to those thanked in my earlier article on the Rosettes (note 1), I would like to thank Robert Hisey (IAP) for helpful discussions on fiber analysis, and again my son Zander, for helping with the examination of the fibers.

## NOTES

1. A more detailed description of the Rosettes with full citations may be found in my article “The Rosette Eagles, Lost Classic Stamps of Mexico,” *Mexicana*, Vol. 61, No. 3 (July 2012), p. 137 & No. 4 (Oct. 2012), p. 206.

2. See Jules Bernichon, *Catalogue Officiel de la Société Française de Timbrologie, Timbres-Poste et Télégraphe, Première Partie – 1840-1900* (Paris 3rd ed. 1908).

3. Charles Pinon, “Histoire Postal du Mexico,” *Mexico Filatelico: Organe Special Mensuel des Colleteurs de l’Amerique Central et des Antilles*, An. 1, no. 6 (Oct. 15, 1910), pp. 2-3; The Editor [C. H. Mekeel], “Notes on the Postage Stamps of Mexico, A Review of Gibbon’s List,” *Philatelic Journal of America*, Vol. 22, No. 7 (Jan. 1912), pp. 241, 243.

4. See Tim Vitale, "Rewetting and Flattening of Historic Paper Supports," pp. 6, 9, on line at [vitalartconservation.com/PDF/flattening\\_historic\\_paper\\_v8.pdf](http://vitalartconservation.com/PDF/flattening_historic_paper_v8.pdf) (accessed Oct. 24, 2015).

5. See "Improvements in Papermaking," *Scientific American*, Vol. II, no. 10 (New Series), p. 153 (Mar. 3, 1860); Julius Grant, *Books & Documents: Dating, Permanence and Preservation* (London: Grafton & Co. 1937), p. 16; John Carter & Graham Pollard, *An Enquiry into the Nature of Certain Nineteenth Century Pamphlets* (New York: Haskell House Pubs., Ltd. 1971, Reprint of 1934 ed.), pp. 43-44; Dard Hunter, *Papermaking: The History and Technique of an Ancient Craft* (New York: Dover Pubs. 1978, Reprint of 1943 ed.), pp. 332-333, 394-396; "Barber and Brothers' Straw Paper Manufactory at Georgetown," *The Sanitary Reporter, a Weekly Record Relating to Gas, Water, Sewerage, and Social and General Science* (London: Edmund Dring), Vol. I, no. 20 (Nov. 13, 1868), pp. 231-232.

6. See Paul Craddock, *Scientific Investigation of Copies, Fakes and Forgeries* (Oxford & Burlington, Mass.: Elsevier: Butterworth-Heinemann 2009), p. 319; Grant, supra, p. 16; Hunter, supra, pp. 392-393.

7. See Grant, supra, pp. 15-16; Hunter, supra, pp. 374-381, 389-396; Carter & Pollard, supra, pp. 42-55; R. H. White, *The Papers and Gums of United States Postage Stamps, 1847-1909* (Germantown, Maryland: Philatelic Research, Ltd. 1983), p. 63.

8. See W. J. Barrow Research Laboratory, *Permanence/Durability of the Book – V, Strength and Other Characteristics of Book Papers 1800-1899* (Richmond, Virginia: W. J. Barrow Research Laboratory 1967), analyzing books printed mostly in the United States and finding that virtually all books through 1870 were printed on pure rag paper. Hardwood and softwood fibers were recorded sporadically beginning in the 1850s along with rag, and straw was recorded in isolated instances as early as 1853, but comprising only 5 percent of the paper. However, one must be careful with the dates assigned to books in this source. For example, it lists a book from 1864 (no. 718) made entirely from soft and hardwood fibers, which would be a remarkably early use of such fibers. In fact, the 1864 date was the book's copyright deposit date, not its printing date. The publisher (Henry Holt & Co.) did not exist until 1872 so the book was in fact printed after 1871.

9. The only study of the fiber content of Mexican stamps of any period I am aware of is Edwin R. Laughlin, "Fiber and Ultraviolet Analysis of Scott #724, 708, 636," *Mexicana*, Vol. 18, no. 4 (Oct. 1969), ref. p. 560. Laughlin analyzed three stamps from 1923-1936 and found esparto (a grass) and softwood fibers.

10. See also John H. Barwis, "Paper Characteristics of U.S. 3¢ Stamps, 1870-1881," in Lera, Barwis & Herendeen (eds.), *Proceedings of the First International Symposium on Analytical Methods in Philately* (Washington: Smithsonian Institution

Scholarly Press 2013), pp. 5, 11-13, examining the stamps' fiber content.

11. See also Calvet M. Hahn, "The Topic is Paper" (U.S. Philatelic Classics Society, New York Chapter, website 2002), on line at <http://www.nystamp.org/postal-history-articles/the-topic-is-paper/> (visited Dec. 6, 2015); White, supra, pp. 47-48, 63-66.

12. Dard Hunter, supra, p. 479.

13. Hans Lenz, *Historia del Papel en México y Cosas Relacionadas: 1525-1950* (Mexico City: Miguel Ángel Porrúa 2d ed. 2001), pp. 180, 461, 495, 530.

14. "The Mexican Empire," *Richmond Daily Dispatch*, Aug. 4, 1863.

15. "Mexico," *The New American Cyclopaedia: a Popular Dictionary of General Knowledge* (New York: D. Appleton and Co. 1867), Vol. XI, pp.436, 443.

16. Report of David H. Strother, Consul-General to Mexico, in U. S. Department of State, *Commercial Relations of the United States: Reports from the Consuls of the United States on the Commerce, Manufactures, etc., of their Consular Districts* (Washington: Government Printing Office 1883), No. 27 (Jan. 1883), pp. 58-60. Carrera Stampa, *La Historia del Correo en Mexico* (Mexico City: Secretaria de Comunicaciones y Transportes 1970), p. 229, stated that the stamps of 1856-1883 were generally printed on French paper. This work, often inaccurate, cites no source for this statement which may be based simply on the "La Croix Freres" watermarks appearing on issues of 1872 (NF w2 paper) and certain 1874-1879 stamps (NF yy paper).

17. Marja-Sisko Ilvessalo-Pfäflli, *Fiber Atlas* (Berlin, Heidelberg, New York: Springer-Verlag 1995).

18. See *Fiber Atlas*, supra, pp. 308-309; Technical Association of the Pulp and Paper Industry ("TAPPI"), "Species Identification of Nonwood Plant Fibers (T 259 sp-05)" (2009), Sec. 10.1.2 and figs. 7-12.

19. Irving H. Isenberg, *Pulp and Paper Microscopy* (Appleton, Wisconsin: The Institute of Paper Chemistry 3d ed. 1967), pp. 150-161 and figs. 77-82A, available through link at <http://smartech.gatech.edu/handle/1853/11673> (visited Dec. 6, 2015).

20. TAPPI, "Fiber Analysis of Paper and Paperboard (T 401 om-03)" (2008), Appendix, Sec. H.1.3.

21. NF references are to Nicholas Follansbee, *A Catalogue of the Stamps of Mexico 1856-1910* (Ashland Oregon 3rd ed. 2007).

22. See *Fiber Atlas*, supra, pp.12-13, 60-163; Isenberg, supra, Fig. 77.

23. See *Fiber Atlas*, supra, pp. 308-309; TAPPI, "Species Identification of Nonwood Plant Fibers (T 259 sp-05)" (2009), Sec. 10.1.2 and figs. 7-12.

24. John D. Hankey, "Report to Farley Katz, Quantative Fiber and Species Analyses" (July 16, 2012).

25. See fn. 8, supra.





# Modeling Postal History with Postal Numbers

*Diane DeBlois & Robert Dalton Harris*

---

**ABSTRACT.** This project models the actual design of the postal system as reorganized by law in 1836. Analyzing details of system mapping and mail contracts, enhanced by both operational and fiscal data reported annually, reveals comparative performance by state and region, as well as interesting local narratives - altogether to characterize postal design during the advent of the railroads.

## INTRODUCTION

A map that is most often used to reference the United States postal routes of the 1830s betrays nothing but the system extent, absent of design (see Figure 1). Ironically, the United States Post Office Department at that time was being reorganized, and annual reports published of mode, frequency and schedule for all mail contracts along with a map, in thirteen sheets for the entire country, that indexed the post roads according to their service of the mail by four-horse post coach, two-horse stage, or horse with rider.

An examination of these published contracts discloses a pattern of organization which can then be combined with information from the Official Registers about the pay of contractors, postmasters and clerks, to provide a complete snapshot of postal operations from the local to the national scale.

## SYSTEM DESIGN

For contracting purposes, the country was divided into four sections: four-year contracts, every four years, cycling in turn by section.<sup>1</sup> The first section to be covered by the design for the reorganization comprised New England and New York.<sup>2</sup> We focused upon New York, the Empire State, where four-year contracts, in turn by five blocks, generated mode, frequency and scheduling – the recursive branchings that covered the more than 1700 post offices.

The numbered contracts for carrying the mail, all traversed by horse at an average speed of four miles an hour, are of three distinct types. The principal routes, about 100 miles long, typically were operated as lines with daily departures from both ends by four-horse post coaches running night and day (see Figure 2). The secondary routes, about 35 miles long, were traversed by two-horse vehicles in daylight, shuttling out one day and back the next, thrice weekly. The tertiary routes, about 15 miles on average, were served, farm to market, out in the morning back in the evening, by horse with rider (see Figure 3).

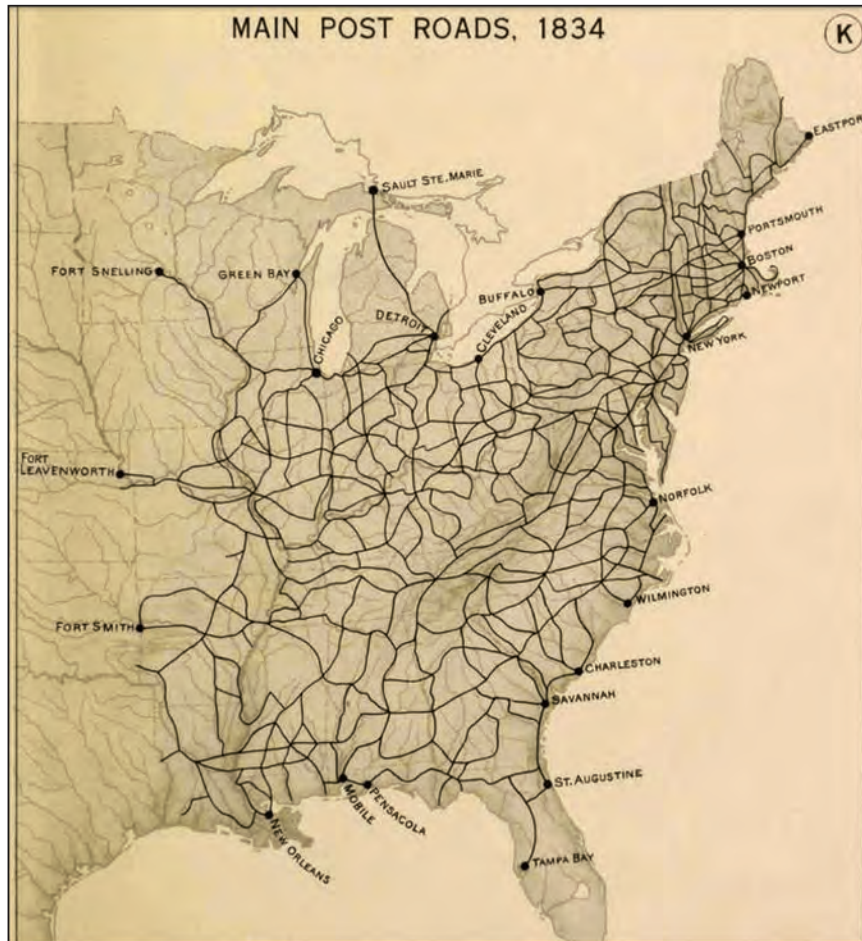

FIGURE 1. Plate 148K from Charles O. Paullin, *Atlas of the Historical Geography of the United States*, Carnegie Institution DC 1932. Information was based on newspapers publishing “Proposals for Carrying the Mails.” Paullin’s explanation for using 1834 (his previous plate dates were 1774 and 1804): “the year 1834 marks with sufficient precision the beginning of the transportation of the mails by the railroads and is near enough to the date of Burr’s post-route maps (1839) to make them a valuable source of information.”

In the course of a week a typical daily primary line would accumulate a maximum of 1400 miles of mail transportation, a typical tri-weekly shuttle a maximum of 210 miles of mail transportation, and a typical farm to market at least 30 miles. Multiplying by 52 gives the annual contribution to the transportation miles of the system.

Special Post Routes were also created to serve singular offices (see Figure 3). The Postmaster General had always been empowered to establish special offices, to be supplied by riders who were to be paid no more than the net revenues. Formerly, such offices, especially in New York State, had risen as the staging companies were encouraged by monopolies – which could be farmed for the net postages from the included post offices – to promote travel to remote settlements. Now, upon the reorga-

nization of the Post Office Department, Congress ordered more new service than could be paid for out of expected revenues. So the gambit of special offices became important to the extension of postal service into new territory.<sup>3</sup>

Blocking of the postal routes permitted not only the tight scheduling of the connections among first class lines, but also provided for timely exchanges of mails with the second and third class carriers (see Figure 4).

The organization of the New York State contracts by numerical sequence began with #501, which was by steamboat daily on a line between New York City and Albany with departures from both ends during the season of navigation. Parallel paths traversed by four-horse stage coaches typically sufficed for mail and passenger traffic during winter months. In this model

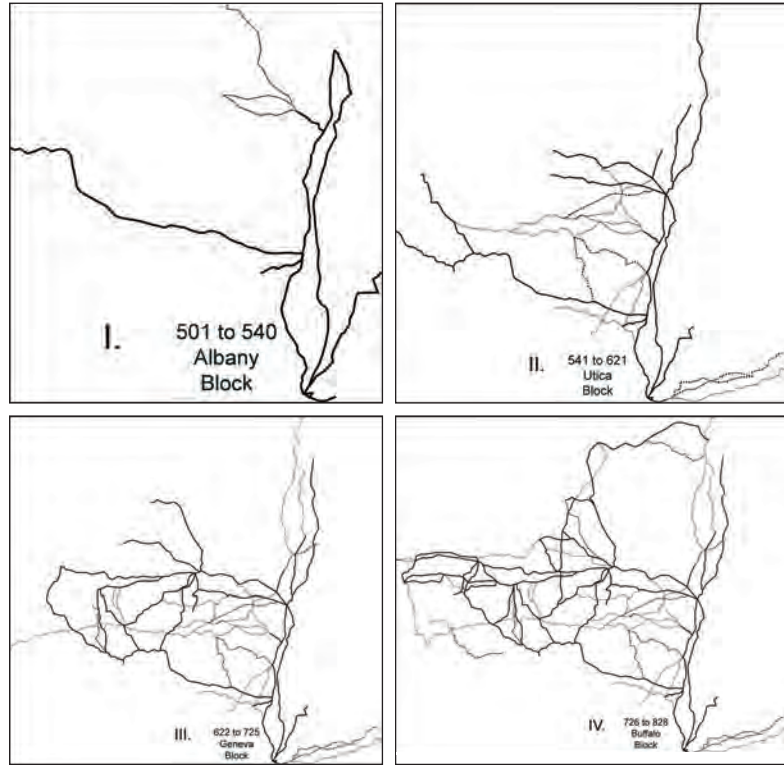

FIGURE 2. 1837 First Class Postal Routes, traced in block segments upon David Burr's 1839 map of New York State. The daily first class mail lines are in bold (thinner lines indicate thrice weekly, dotted lines are twice weekly or weekly). This was the fast track for the long distance distribution of daily newspapers.



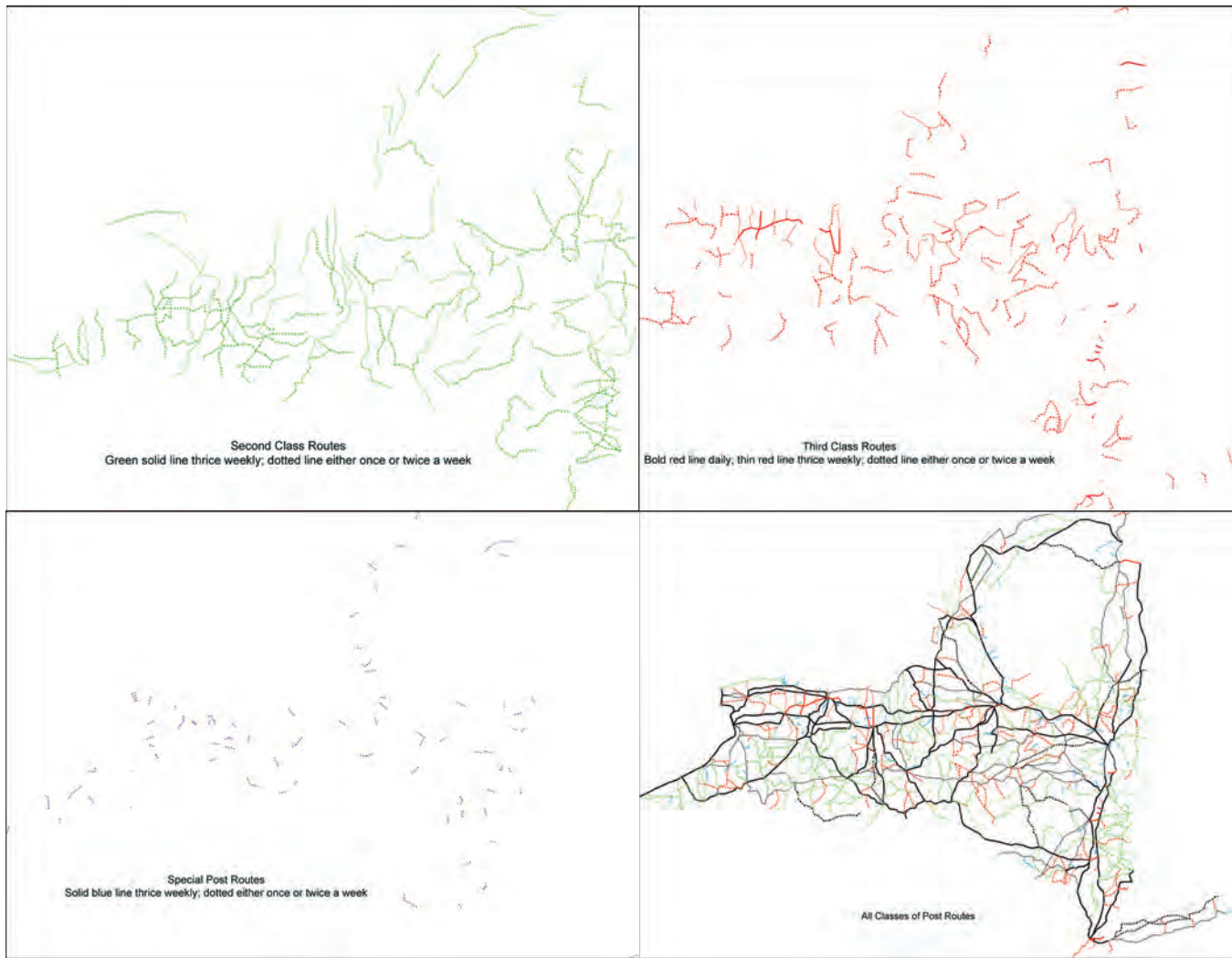

FIGURE 3. The recursive branchings of the Second Class (solid green line thrice a week, dotted line either once or twice a week), Third Class (bold red line daily, thin red line thrice a week, dotted red line once or twice a week), and Special Postal (solid blue line thrice weekly, dotted line once or twice a week) Routes fill in the design of the system as organized for New York State by the 1837 postal contracts.

we concentrated on the winter mail transportation schedule for New York State to highlight stage coaching for its contribution to the design, even as the railroad emerged to overtake it.

Mail pay for each mode of transportation was proportionate to length of route and frequency of performance, to contribute to a global measure of transportation miles. Though four-horse post coaches might cost twice as much per transportation mile as horse and rider, they could haul twenty times as much mail. For economies of scale then, the mail was aggregated as quickly as possible to the climax carrier.

Even as stage coaching was enjoined to the expedition of the mails, railroads loomed as the next best thing. They, too, were assigned three classes as mail carriers: the law enacted March 3, 1845 called for a First Class Railroad to be paid no

more than \$300 per mile per annum; Second Class no more than \$100; Third Class no more than \$50.<sup>4</sup>

## POSTAL TRANSPORTATION

The Postmaster General provided annual measures of his system, by state: miles of post road for the first column; total transportation miles for the penultimate column; total cost for the last. Interior columns of data are distributions by mode (see Figure 5).

Abrupt changes in the configuration of mail transportation appeared in contract years. An essential resource for interpreting these changes was the detailed tabulation of railroad and

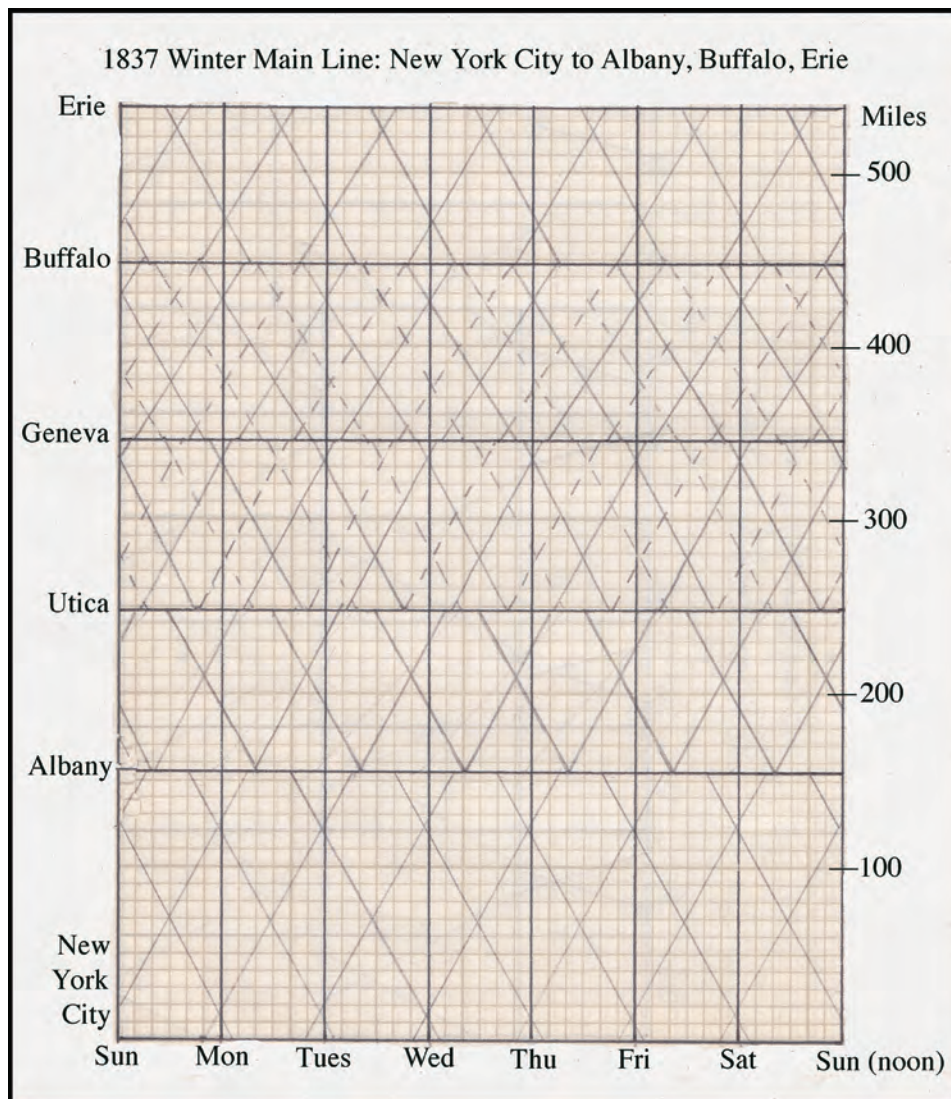

FIGURE 4. Four-Horse Post Coaches. Moving from top to bottom, or bottom to top, follow the diagonal path to the right. Upon reaching the right margin, noon Sunday, return to the left margin. For example: from the bottom, leaving New York City Monday am. Short stop at Albany Tuesday pm, leaving for Utica to arrive the following pm, Geneva Thursday pm. And into Buffalo Friday pm. Some 450 miles in 4+ days, or about 100 hours, averaging 4.5 miles per hour.

steamboat mails according to the state in which their performance was accountable, found also within the Postmaster General's annual reports.

The Total Annual Transportation Miles for each state were also divided by 104 (round trip x 52 weeks) times the route miles to obtain an effective frequency of their mail service (see Figure 6). Based upon the design and record, the national counterpart of this model was developed to reflect the differences in frequency of service mapping upon the state. Between 1843 and 1860, a daily effective frequency emerged in Massachusetts, New York, Connecticut, Rhode Island, and the Mid-Atlantic

States. Ohio and Georgia managed semi-weekly service prior to the Civil War, just as Illinois emerged as the transshipment center for both the Mississippi South and the trans-Mississippi West.

### POSTAL ECONOMY

The postal service of the American colonies had been farmed to make money for its proprietors, and sometimes it did. In its early years, the United States post office generally made money. After reorganization, however, the policy was

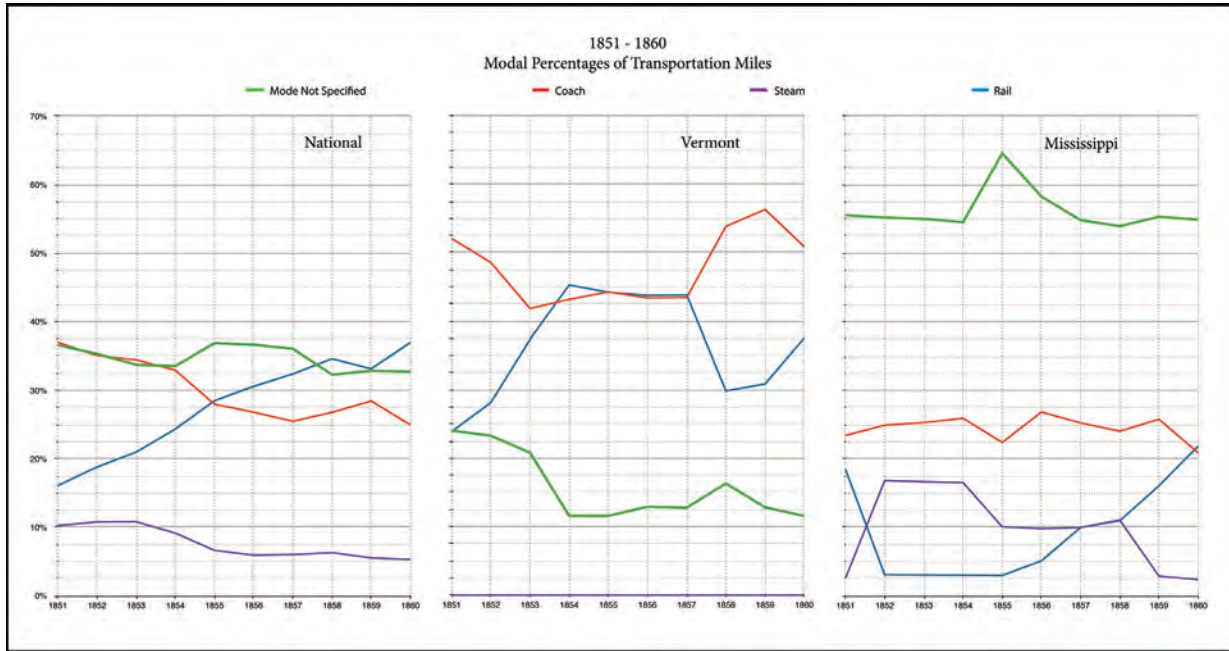

FIGURE 5. These states are two years apart in the four year contracting cycle: for Vermont, 1853 and 1857; Mississippi 1851, 1855, and 1859. The national framework showed the railroads surmounting all other forms of delivery, most particularly the stage coach, while statewide representations showed more or less steady percentage contributions from the coach. Indeed, the Vermont coaching contractors regained a hegemony as railroad service increased from 6x to 12x a week, then waned. Steamboat contributions were most problematic because they served long distances between ports in different states and might be allocated to either. The Champlain steamboats between New York and Vermont were charged to New York during these years. So, too, the steamboat miles shown for Mississippi were dependent upon whether or not the Vicksburg and New Orleans line was charged to Mississippi or Louisiana.

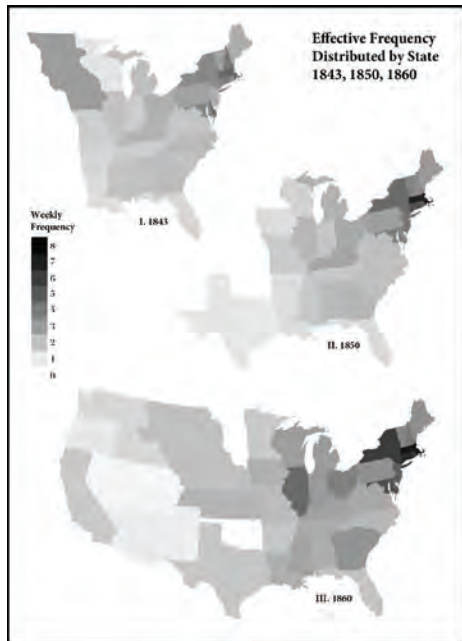

FIGURE 6. Effective weekly frequency of the antebellum mails for each state.

to reinvest excess revenue to enable an increase in services. The systematic investment by the Post Office Department in the transportation system drove a growth of 7% per annum, which doubled revenue every ten years, and almost in spite of changes in postage, transportation technology, geographic extent, or population. Exceptions at mid-19<sup>th</sup> century were during postal reform, territorial expansion and civil war (see Figure 7).

Tabulating the Auditor’s data shows that postal revenues in Massachusetts exceeded postal expenditures, while the opposite occurred in Georgia (see Figure 8). Nowhere in the Atlantic or Mississippi South, nor the trans-Mississippi West, did postal revenues cover expenditures. Excess revenues generated in the Northeast were used to extend the service elsewhere, typically by the superior modes, as had been the practice of pioneer stage coach lines in western New York.

Postmaster commissions were figured as a percentage of the gross revenue of their offices, and should have paralleled the revenue figures. However, the basic rates of the compensation changed, even as the postage rates were being reduced, to maintain the levels of their emoluments.<sup>5</sup> Though the incidental expenses, chiefly for the clerks, of the post offices constituted the least part of the expenditures, it was evident these expenses would overtake postmaster commissions in Massachusetts, an indication of the industrial urbanization of the Commonwealth.



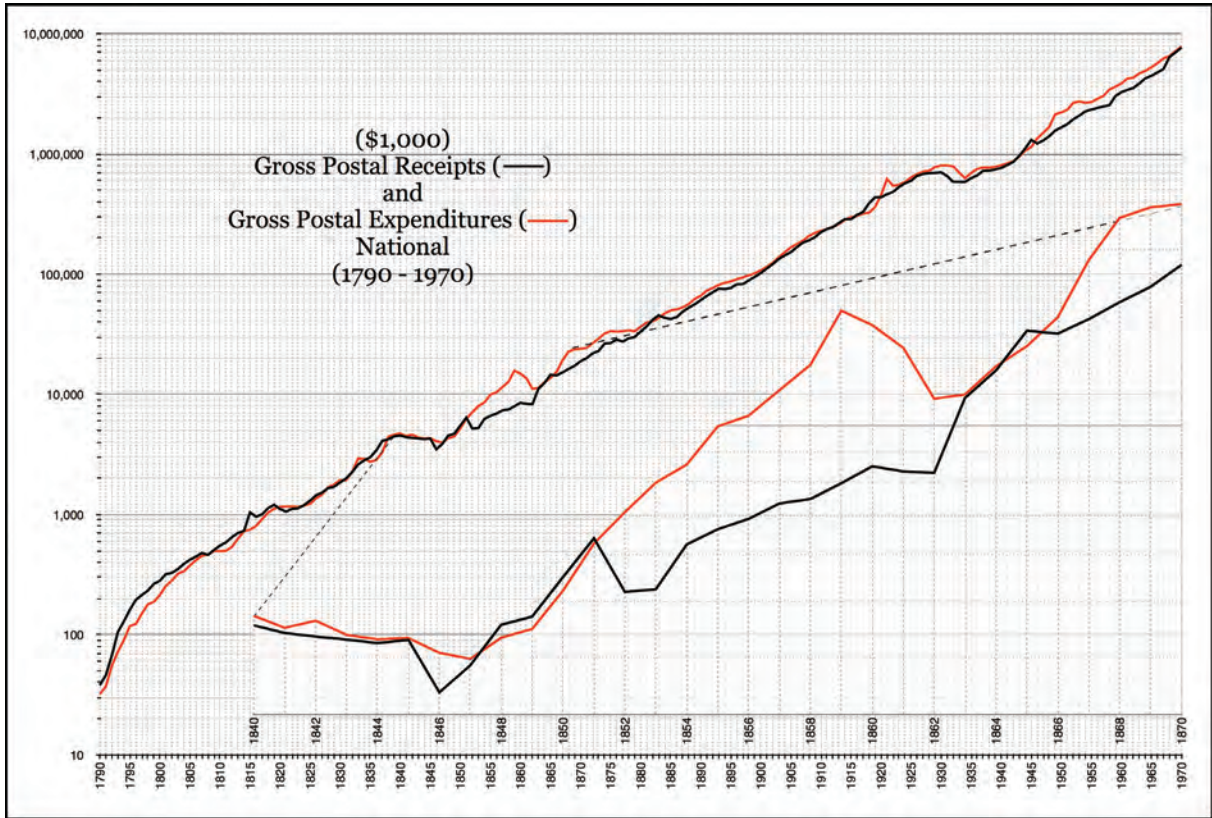

FIGURE 7. Revenues and expenditures of the postal service over 180 years; a logarithmic scale showing an annual rate of growth of 7%.

On the revenue side, we chose to highlight the proportion of the total receipts paid by newspapers. It was between 10 and 20% in New York and New England (see Figure 9) and 5 to 15% in the Southern Block (see Figure 10) until the postal reforms of 1845, when the decrease in letter postages raised newspapers to 25% of the revenue in the most remote portions of either region – Vermont in the Northeast, North Carolina in the South.

After 1851, the substantial decline in the newspaper portion of the revenues, even against the final reduction of prepaid letter postage to three cents, was the free distribution accorded in the mails to weekly newspapers in the county of their publication. Though 1851 marked the addition of books as mailable matter, and Hartford was regarded as the nation’s subscription book publishing center, we have yet to confirm this as the explanation for the anomalous Connecticut increase in the proportion of revenue from newspapers (and other printed matter). Mail was reclassified in 1863, and newspaper postage was reduced another 50%.

The Civil War data for the Confederate States of America, who were constituted to balance their postal budget and did, is the blank space in our picture (Figure 10). During the war, revenues met expenditures in the rest of the nation (Figure 7). By 1870, newspapers averaged 2.5% of the revenues in the Northeast, 5% in the South.<sup>6</sup>

## LOCAL

Six daily, and one thrice-weekly, first class four-horse post coach lines traversed Rensselaer county, calling upon the headwaters of the Hudson estuary, from New York and Canada and points along the Connecticut River. The center of the county was crossed by weekly second class mails. (See Figure 11).

A daily third class route connected Hoosick to Hoosick Falls where Walter Wood established his agricultural works - starting from Hoosick Falls daily at 10 am to arrive in Hoosick by 11 am, in time to pick up letters from Troy and leave letters for Troy on the line passing through Bennington to Brattleboro, Vermont. Hoosick had previously been served by a weekly horse mail, but an 1834 survey for a potential railroad route to Boston, supported by Troy mayor George Tibbits, made an appeal for new status, at the same time as postal revenues from Hoosick Falls were surpassing those of the Hoosick post office from which its service depended.

Two Special Post Offices index a significant post road abandoned in the new design (Wynantskill to West Sand Lake, and Albany to DeFrestville, marked in blue, Figure 11). Beginning in Albany and passing through Sand Lake and Centre Berlin to Williamstown, the King’s Road had formerly

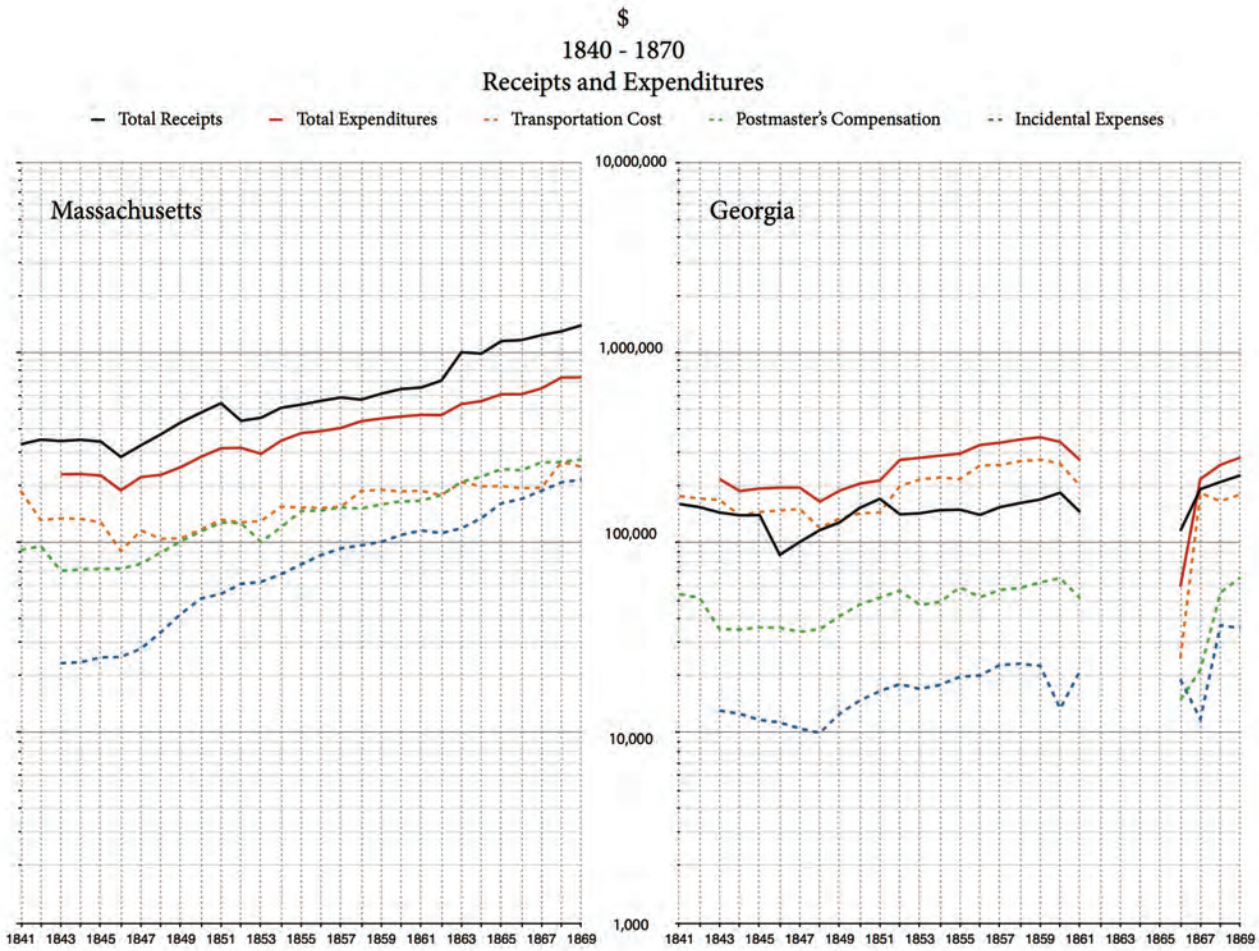

FIGURE 8. Comparing receipts and expenditures of a Northern and a Southern state. Revenues declined as transportation expenditures increased in 1851 in Georgia. By mode, the increase is given to the railroads, but the tabulations of railroad contracts by state show no new service in Georgia between 1851 and 1852. Evidently the increase is an artifact of the accounting for the interstate railroad line between South Carolina and Georgia serving the Great Southern mail. The plunge in all but incidentals for Georgia in 1861 reflects secession to the Confederate States of America. The stimulus of war in the industrialized Northeast might plausibly account for the surge in postal revenues in Massachusetts by 1863.

connected Albany with the Hampshire Grants - the strategic road Burgoyne hoped to find to attack Albany. In 1837, Sand Lake, West Sand Lake (where we live), and the Wynantskill Watershed were becoming part of Troy's hinterland.

The Official Registers provide a biennial resolution of our model on the local scale, not only reporting upon the pay of the postmasters, clerks and contractors constituting the postal expenditures, but also upon the gross postal revenues of each post office (see Figure 12).

**CONCLUSION**

Selah R. Hobbie (Assistant Postmaster General 1829 to 1851) and David H. Burr (Official Post Office Topographer

1832-1838) designed a postal system for the economies of scale of the four-horse post coach. They based this on a classification of modes and on rates of pay by miles of post road. Railroad mail pay was similarly classified. Consequently, the railroads, as they became systematically invested with the postal design, not so much supplanted as they extended the service of the horse; not so much eradicated as they conserved the relative isolation of remote places.

**ACKNOWLEDGMENT**

Che Perez spread the data from the annual reports of Hobbie and the Auditor, and helped to develop striking and meaningful representations of its richness, for all the graphs and the maps of effective frequency (figure 6).



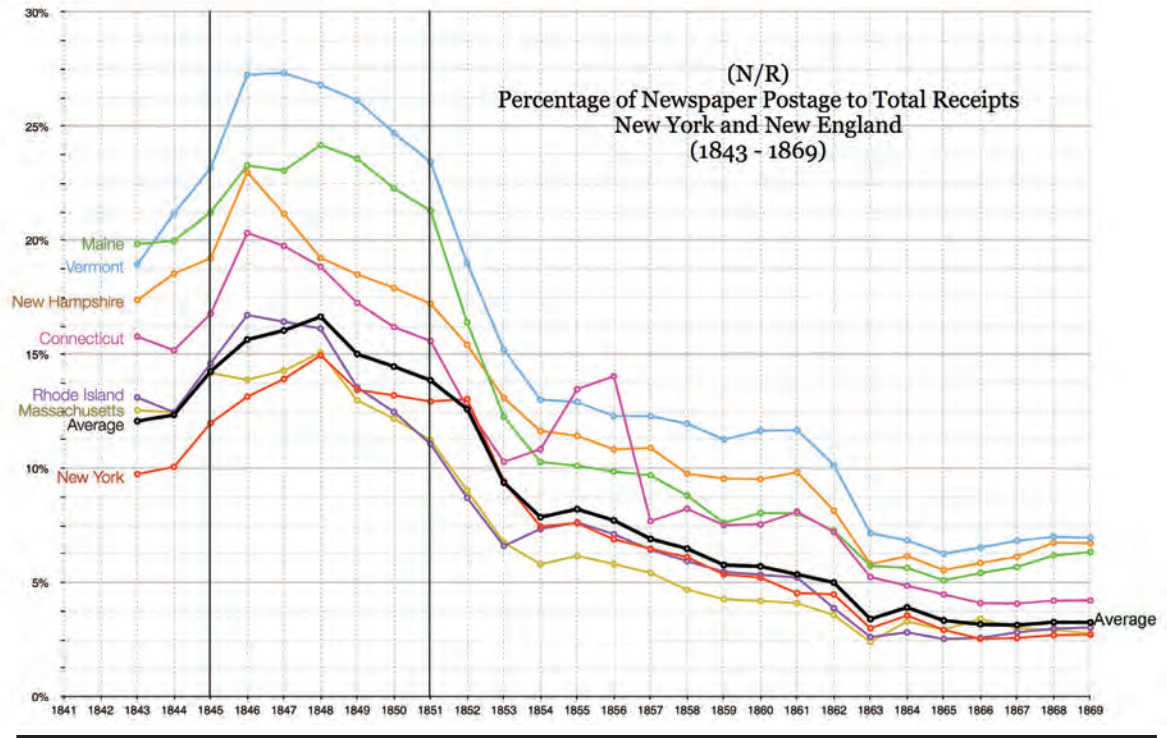

FIGURE 9. For the New England states and New York, graphing the percentage of newspaper postage to total postal revenues, 1843 to 1869 – with lines to indicate the postal reforms of 1845 and 1851.

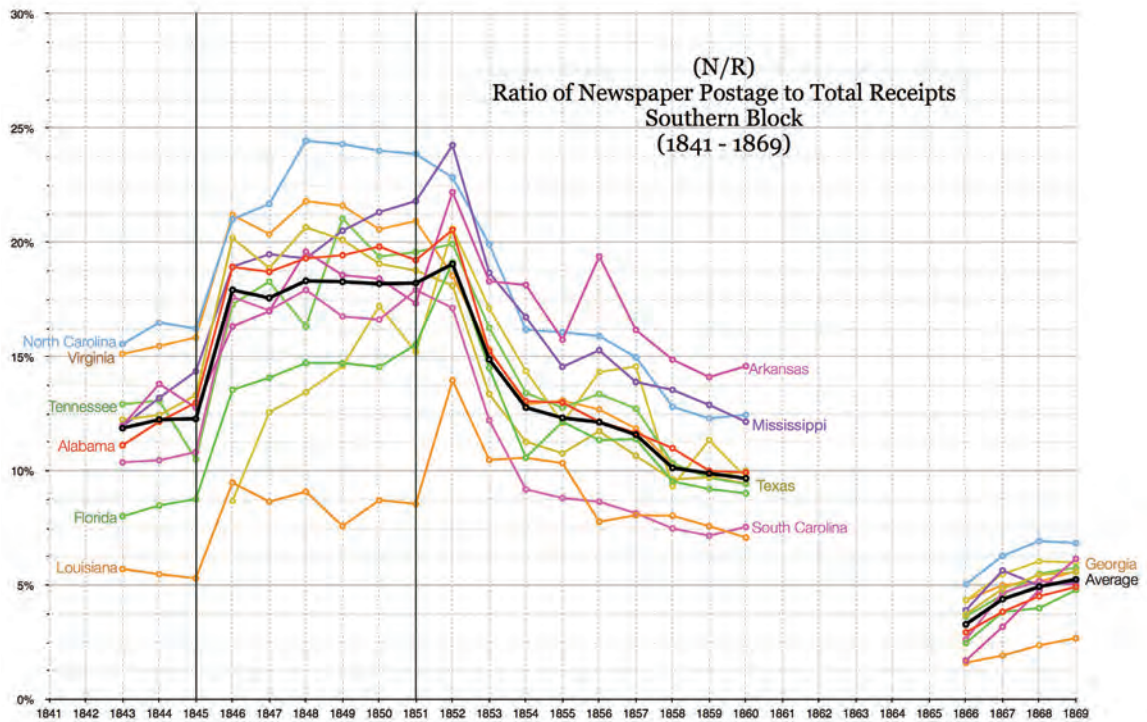

FIGURE 10. For the states in the Southern Block, graphing the percentage of newspaper postage to total postal revenues, 1843 to 1869 – with lines to indicate the postal reforms of 1845 and 1851.





FIGURE 11. On a detail from Burr's 1839 map of New York State, Rensselaer county is marked with the difference classes and frequencies of postal routes that traversed it (color represents class: black is first, green is second, red is third, blue is special; bold lines are 6 or 7 times a week, thin are 3 times a week, dotted are 1 or 2 times a week).

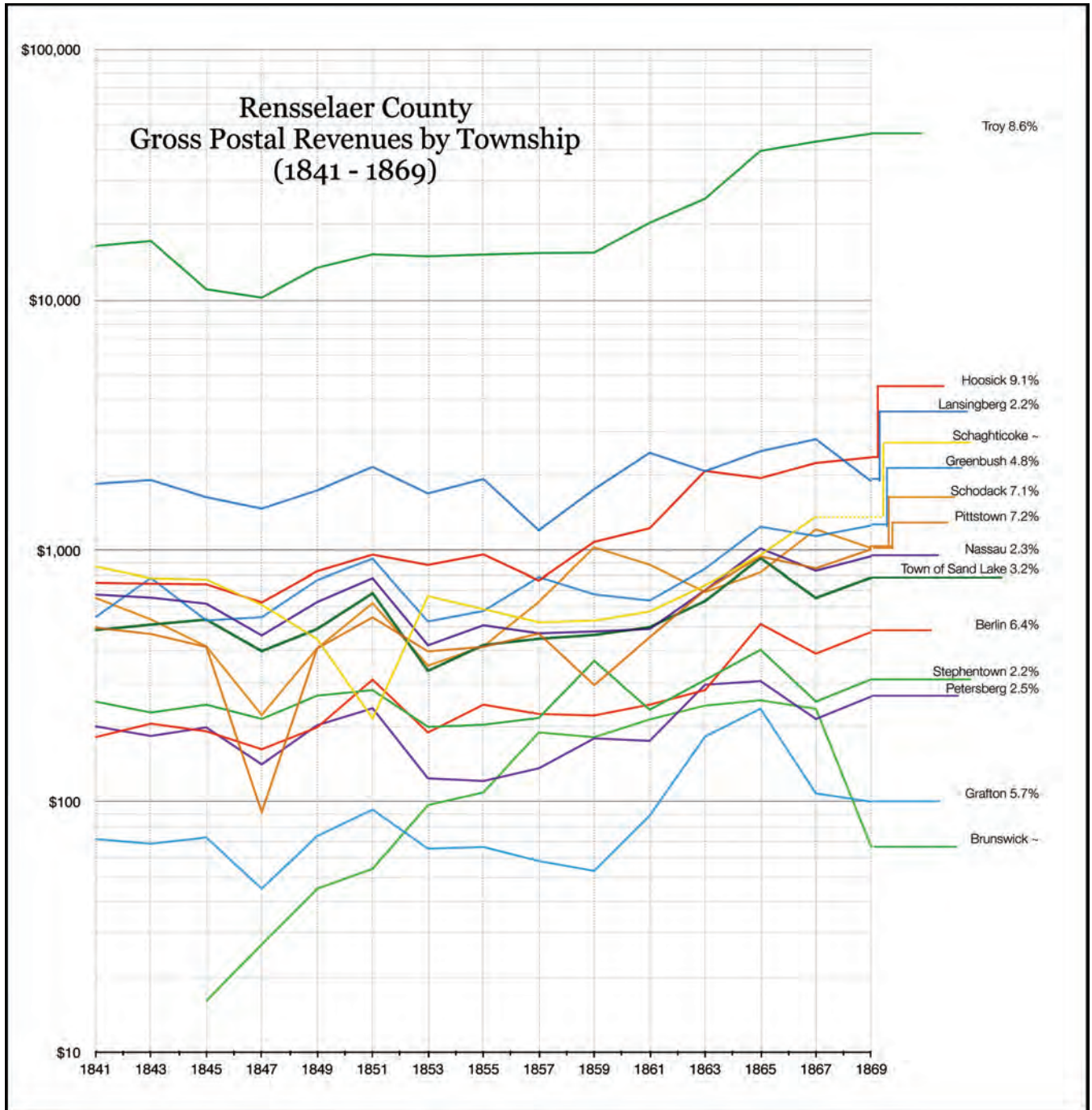

FIGURE 12. Postal revenues by township generally grew at rates in proportion to the magnitude of their revenues (ie: exponential growth), thereby conserving rank order. The most productive and fastest growing townships lined the Hudson River. The central townships produced little and grew slowly.

## REFERENCES

Burr, David H. *Map of New York Exhibiting the Post Offices, Post Roads, Canals, Rail Roads, &c.* 1839. Library of Congress G3800 .B8 RR 259, Digital Image.

Harris, Robert Dalton, *Postal Route Gazetteer Part 1 New York State 1839*, Fishkill NY 1992. (Available as a pdf download through Wordpress, or in print with a large copy of the Burr map. This volume lists all the 1837 contract routes for New York State. A separate index by post office is available from the authors.)

Robert Dalton Harris, "The Three Postal Networks of the United States in the 1830s," *Business and Economic History On-Line*, 2004 (<http://www.thebhc.org/publications/BEHonline/2004/Harris.pdf>)

\_\_\_\_\_, *Register of All Officers and Agents, Civil, Military, and Naval, in the Service of the United States*, Washington D.C. Blair & Rives (and others) 1816 to 1911 (title varied, as did printers; authors can provide full bibliography).

\_\_\_\_\_, *Report of the Postmaster General, December 1, 1837* (and annually thereafter) Washington, D.C.: Government Printing Office, 1837. These publications also included the annual reports of the Auditor, as well as detailed tabulations of railroad and steamboat mails.

## NOTES

1. For a bibliography of these contract reports, see Diane DeBlois, "Mail Contracts: Congress & the PMG" *P.S. A Quarterly Journal of Postal History*, vol. X no. 3, whole no. 39, 1988, pp 65-80.

2. House of Representatives 28-2, Document 139, January 31, 1838. *Contracts – Transportation Mail U.S. – 1837*, "Letter from the Postmaster General, transmitting The Annual Report of the Contracts made for the Transportation of the Mail within the year preceding the 1<sup>st</sup> July, 1837."

3. Diane DeBlois & Robert Dalton Harris, "Special post routes & special post offices: Local economies & the postal network of the United States to 1860." *The Congress Book 2013*, pp 25-37.

4. Postal Law of March 3, 1845, Section 19, p 68.

5. Robert Dalton Harris, "Local Sources of Postal Revenue," 2006 Winton M. Blount Symposium, available as a pdf on line at [postalmuseum.si.edu/research](http://postalmuseum.si.edu/research).

6. Diane DeBlois & Robert Dalton Harris, "Newspapers and the Postal Business of the Confederacy" *Postal History Journal* No. 156, October 2013, pp 29-38.



# Canada 1868 Two Cent Large Queen on Laid Paper: The Analytical Process Followed for Expertization

*J. Edward Nixon*

---

**ABSTRACT.** A Two Cent Large Queen (Figure 1) was submitted to the Expert Committee of the Vincent Graves Greene Philatelic Research Foundation in Toronto in March 2013 showing laid lines in the paper. It was not an obvious fake and considerable analysis was undertaken to determine if it was genuine. If genuine, it would be the third known genuine copy.

## **ORIGIN AND PROVENANCE**

The submitted stamp was purchased by the collector early in 2013 from a sales circuit book for a modest price. There was no description of paper type. It was simply a Hamilton dated copy with creases and a tear. He was checking Large Queens for watermarks using back lighting. This was confirmed by the submitter who was known to a member of the Expert Committee. The submitter believed he was not the first person to see the particular circuit book. There seemed to be nothing obviously suspicious about the origin of the stamp.

## **NATURE OF ANALYSIS**

Given the potential significance of the item the Committee decided to do as much analysis as necessary and to be sure the result could be defended analytically why the stamp was determined to be either genuine or a fake. It would not be sufficient to say it “does not feel right” if the decision was negative. The Committee would need to determine how it was created. Equally, the Committee would ensure a positive decision could be supported scientifically and analytically. The Foster + Freeman VSC6000 is the scientific tool used to advance the analysis.

In order to complement the examination by members of the Expert Committee, additional known experts on the Large Queen issue were brought to the Foundation with their material to examine the submitted stamp and to provide extremely useful and important knowledge. Specifically, Richard Gratton, Glenn Archer and Lawrence Pinkney were most helpful.

There were no less than twelve different aspects of the submitted stamp that were examined in relation to Two Cent Large Queen stamps and laid paper varieties in particular.



FIGURE 1. Two Cent Large Queen, reverse showing laid lines.

## GENERAL UNDERSTANDING OF LARGE QUEEN PAPER

Committee members Garfield Portch, Rob Taylor and Ted Nixon spent a day with Richard Gratton understanding paper making in the latter part of the 19<sup>th</sup> century, and how pulp was applied to a wire mesh or screen, then pressed by a dandy roll to remove moisture and excess pulp.

The wire mesh on the paper making machine is stretched and flows in a large loop and carries the pulp. It is understood that all paper has a mesh. The mesh visible within the paper runs in the direction that the wire mesh runs in the machine. Looking at this lengthwise down the wire screen, the mesh will appear to run away from you or run vertical as opposed to having a horizontal prominence running across in front of you.

Whether the paper as viewed on a printed stamp has a vertical versus horizontal mesh has nothing to do with production of the paper. It only indicates the direction that the paper was fed into the printing press. Pieces of paper cut from the same stock or roll can be fed into the printing press at right angles to each other. When the stamp sheet is printed and viewed one will show a vertical mesh, the other a horizontal mesh.

The prominence or visual strength of the mesh has to do with whether the steel mesh in the paper making machine had become more stretched and is related to the thickness and bulk of the pulp or the type of fibres (cotton, hardwood or softwood) which predominated in the pulp. If the fibres are highly refined the mesh will be less visible. Bothwell paper shows a strong coarse pattern which emanates from a less refined pulp and a stretched steel mesh. The vertical grain in the printed stamp is simply the result of the direction the paper was fed into the printing press.

Large Queen stamps were printed on damp paper. After printing the paper shrank slightly across the direction of the mesh. Stamps are seen as either horizontally (H) meshed or vertically (V) meshed with varying degrees of strength to the mesh. For the same stamp value those copies which are (V) will measure taller and narrower than those which are (H). The difference in height, for Large Queen stamps is about .3mm between (H) and (V) meshed stamps. This is a very important feature.

Specialists such as H.E. & H.W. Duckworth have classified 10 printing papers of Large Queen stamps by direction of the mesh, its visibility and paper thickness. It is critical to understand these differences in paper characteristics when analyzing Large Queen printings. Much of this is summarized in an article by Richard Gratton in the *Canadian Philatelist* July/Aug. 2012.

## MEASUREMENTS

The Committee performed measurements using a common ruler and the VSC6000 on a wide range of One, Two and Three Cent Large Queen stamps. This confirmed the differences in height and width for vertically meshed versus horizontally meshed copies. The easiest vertical (V) meshed stamp to use as a standard was the Bothwell watermarked paper, since the mesh is very visible. A number of common papers such as Duckworth papers 3 or 10 show the horizontal (H) mesh clearly and can be used as a standard. It is preferable to pick the maximum width or height just to get more distance when measuring. This will produce a difference of about .3mm in both height and width, as indicated above. When testing for



FIGURE 2. One cent, two cent, and three cent large queens on laid paper.

vertical versus horizontal on a stamp in question one needs three stamps – a known (V), a known (H), and the stamp in question. It doesn't really matter which point on the outer frame of the stamp is picked for measurements as long as precisely the same points are picked on each stamp.

### ADDITION OF LAID LINES IN PAPER PRODUCTION

In the late 19<sup>th</sup> century paper production, a dandy roll was positioned across the steel mesh to press the pulp against the mesh and squeeze out the water. If laid lines were desired in the paper, then wires were attached across the dandy roll and these wires impressed lines in the pulp at right angles or perpendicular to the flow of the pulp in the paper making machine. This important feature has been confirmed by Richard Gratton, Glenn Archer, and Alex Hutton in BNA Topics. The result is that by definition Large Queen stamps which show horizontal laid lines will measure as vertically meshed stamps because the laid lines were applied perpendicular to the flow of the mesh in paper production.

The Committee focused on One and Three Cent Large Queens, on Duckworth Paper 5 which is the laid paper category. The Committee had a number of One and Three Cent copies available which were considered genuine, and all measured (V). It is fair to say in the past this was not a test performed by the Greene Foundation Expert Committee to determine genuineness of a One or Three Cent stamp submitted as laid paper.

As a result of this analysis, it seems clear that this should be the first test in the process. Essentially if a stamp showing horizontal laid lines measures (V), it has a chance of being genuine. This is a good but not sufficient test. If it measures (H), it is almost certainly a fake.

The submitted Two Cent stamp measured as a vertically (V) meshed stamp.

The Committee researched the photos of some of its issued genuine and false certificates for One and Three Cent

Large Queens to enhance its findings. The certificate photo does include a measurement guide. An initial review over the past 2 years found two false certificates for One Cent laid paper copies which had been slightly contentious. A check of the (H) and (V) measurements in the photo now confirmed each was in fact horizontally meshed which means neither were genuine laid paper.

### THICKNESS OF LAID PAPER

The One Cent laid paper is a relatively thick soft paper, with some variation in thickness recorded. It seems to range from about .0031in to as high as .0039in, but generally in the .0035in range. The Three Cent is a thinner paper falling more tightly in the .0026 to .0029in range. The Two Cent is said to be a thicker paper similar to the One Cent (Figure 2).

It was relevant to consider if there are any other large queen papers that have the thickness and softness of the One Cent laid paper. Duckworth Paper 8 was noted as being soft, white and generally in the .0035in range, although copies seen by us were thinner. But it is horizontal meshed. It exists for the One, Two and Three Cent values, and others. The Committee investigated if this had ever been seen with a vertical mesh grain. In fact, at this point the Committee had not seen any One or Three Cent thick soft paper measuring as thick as .0035in, (H) or (V) mesh, other than the One Cent laid paper.

The submitted Two Cent is .0036in thick on a soft paper very similar to the One Cent laid paper.

### VISIBILITY OF LAID LINES

The visibility of the laid lines can be a useful test of laid paper. On the Three Cent it is relatively easy to see the lines on the reverse since the paper is thinner. For the One Cent the lines are usually visible on the reverse but sometimes the surface can be pressed smooth so the lines are visually somewhat





FIGURE 3. Laid lines using the VSC 6000 as seen from front with 365nm transmitted ultraviolet light, and from the back using spot fluorescence.

buried within the paper. It is also important to see a shine of the laid lines on the front of the stamp. This can be done by holding the stamp at an angle to good light and sighting either from the side or bottom. This was confirmed with a number of genuine items. Generally, those with faked laid lines do not have the shine of visible lines on the front of the stamp.

The lines are always more visible on reverse when the stamp is placed in water or watermark fluid, which is the traditional test.

The submitted Two Cent had visible laid lines without being in any fluid (Figure 3). On the back the surface was reasonably smooth but the lines were quite visible. On the front the lines could be seen viewed from the side, but not as easily from top to bottom across the lines. When placed in either water or watermark fluid the laid lines were clearly visible. The vertical line is called a verge line.

The submitted stamp took longer to dry in watermark fluid than a One Cent laid paper which was somewhat puzzling given the apparent similarity in paper. However, it did not exhibit qualities of a rebacked stamp which often occurs when such an item is placed in fluid.

### SOAKING THE STAMP IN WATER

The Committee soaked a variety of Large Queen stamps in water. The sides of vertically meshed stamps will curl when the stamp is first exposed to water, - the top and bottom of a horizontally meshed stamp will curl when the stamp is first exposed to water (Figure 4). Each will then flatten out as the water is absorbed in the stamp. The different (H) and (V) meshed papers of Large Queens were tested and this property was confirmed.

The submitted Two Cent stamp was placed in water alongside a genuine One Cent laid paper copy. The sides of each stamp curled in the same manner and then flattened out. Since they reacted the same, each was clearly a vertically meshed stamp.

The submitted Two Cent stamp displayed no properties of a rebacked stamp when placed in water. It did not separate from any rebacking. Further it was soaked several times and never

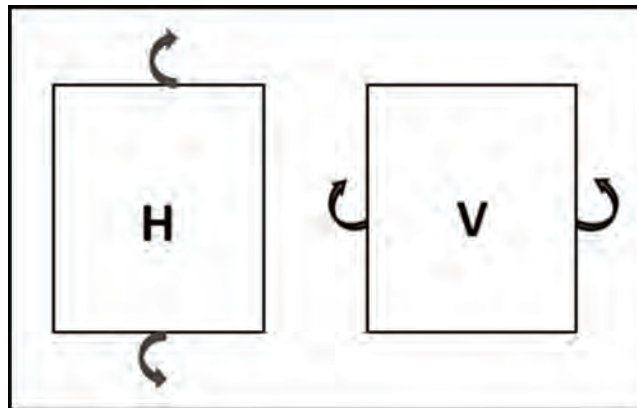

FIGURE 4. Horizontal or vertical mesh.

curled in an unusual manner. It did not reject water in any area of the stamp and it dried in the same consistent manner as the genuine One Cent laid paper copy each time it was soaked.

### WIDTH OF LAID LINES

Using the VSC6000, the laid lines on the Three Cent are about 14 per 2cm. and the lines on the One Cent are about 13 per 2 cm. The laid lines on the Two Cent submitted stamp did measure 13 per 2cm. using the VSC6000. In addition, using the VSC6000 we were able to overlay the Two Cent on a One Cent laid paper copy and the lines matched perfectly with each other.

### COLOUR OF PAPER

The Large Queen stamps come in degrees of whiteness of paper which vary by type of paper as recorded in Gratton's article. It has been observed that the One Cent laid paper is slightly off-white in colour. By comparison Duckworth paper 8 which is soft is a pure white colour. It is, however, horizontally meshed. In a J. N. Sisson's November 1971 auction catalogue which sold one of the Two Cent laid paper copies, the paper was described as "thick, yellowish".

The submitted Two Cent copy showed an off white colour similar to One Cent laid paper copies examined, but not very yellowish.

### TEXTURE OF PAPER

The submitted Two Cent was placed beside a One Cent laid paper copy at high magnification under the VSC6000. The texture and mix of paper fibres was viewed. The two papers certainly appeared the same. There were flecks of different coloured fibres in each paper.

Both copies show some feathering of perforation tips consistent with a thicker softer paper. Of course the degree of feathering of perforation tips can certainly vary from stamp to stamp



FIGURE 5. Hamilton cancels - registered blue cancel and two ring "5".

and within the same stamp will often vary on each side of the stamp. Photos of the existing two laid paper Two Cent copies do show some slight differences in crispness of perforation holes.

### QUALITY OF IMPRESSION

It is often said that the impression of a One Cent Large Queen on laid paper should be strong but blurred because the paper is soft and reasonably absorbent. However, this does vary slightly with the thickness and softness of paper from copy to copy. The Committee believes the impression on the One Cent laid paper is quite strong, the colour is intense and actually a much finer impression than some other printings. However, it is not the very crisp, clean precise image that exists on a Duckworth paper 8 copy by comparison.

The quality of the impression on the Two Cent submitted stamp was strong and intense in colour, but not as crisp as a paper 8 printing. It is what would be expected on the same paper as used for the One Cent laid paper.

### PERFORATIONS

The Large Queens typically were perforated 11.9x11.9 for printings before 1872. There can be minor variations on this but not as far as to 11.75 or to 12.25. Sometimes a side will appear closer to 12 than 11.9. The submitted Two Cent stamp measured 11.9 plus a bit on three sides while the top seems more like 12, as measured on both the normal Stanley Gibbons gauge and the VSC6000. Perhaps some further analysis is warranted on this issue but it really does not affect the paper variety.

### HAMILTON DATE STAMP

The submitted Two Cent stamp had a centred Hamilton, March 16, 1870 date stamp. In fact, the cancel was so nicely centred and perhaps used a bit late on a laid paper copy that its validity was questioned. Generally, the One Cent laid paper copies were considered to be used earlier than this time. However, there are precious few known dated copies of the One Cent. Examination of Two Cent Large Queen dated copies in a specialist collection revealed a surprising number of Hamilton dated copies in the 1870-71 period- more so than for other

prominent cities.

The observed Hamilton dates on Two Cent copies were as follows:

August 24, 1868	December 13, 1870
September 7, 1868	March 6, 1871
March 21, 1869	April 13, 1871
May 5, 1869	April 15, 1871
March 9, 1870 (blue cancel; paper 6)	April 24, 1871
August 31, 1870	December 29, 1871

Thus the Two Cent Large Queen stamps clearly were used in abundance at Hamilton up until the Small Queen value was issued in March 1872. Several hammers were used at Hamilton and different colours, including blue were used. Since the Two Cent Large Queen would usually be used in combination with a One or Three Cent value it would not be unusual for the Two Cent to receive the date stamp portion of a cancel.

It should be noted that the copy with a blue March 9, 1870 date stamp, in the above list, is a week before the date on the submitted Two Cent stamp. One of the existing Two Cent laid paper copies has the Hamilton "5" two ring cancel. The other laid paper copy has a blue REGISTERED hand stamp, with margins that are almost identical to those of the submitted stamp (Figure 5).

It appears possible that the Two Cent laid paper copies came from the same sheet of stamps and they were used at Hamilton in March 1870.

### POTENTIAL TO FAKE THE TWO CENT LAID PAPER

The submitted stamp is not rebacked. It has been soaked in water several times. It has been soaked alongside a One Cent genuine laid paper copy and alongside a rebacked faked One Cent laid paper copy. The stamp has never shown any unusual signs when being soaked or when drying. It curls from the sides on drying as does the genuine One Cent laid paper copy, thus confirming it is vertically meshed. Also no rebacking was evident under the VSC6000.

If the laid lines had been impressed in the paper after printing, it would have been necessary to find a thick soft paper Two Cent copy measuring about .0035in thick, which was also on vertically meshed paper. We do not believe such a printing of the Two Cent exists. It may be possible to find a thick soft paper Two Cent copy on horizontally meshed paper measuring .0035in, but we have not seen one of these either.

### VERTICALLY MESHED PAPERS OF THE TWO CENT

An important aspect of the analysis is to consider how a credible fake of the Two Cent on laid paper could be made. The stamp must be on paper that measures tall like a vertically meshed stamp. Clearly if it was rebacked there are known procedures to detect this and it would not be a credible fake.

The vertically meshed papers of the Two Cent are Duckworth papers 1, 6 and 7. Paper 1 appears thin, semi-transparent,



FIGURE 6. Laid Paper vs. Duckworth Paper 1.

about .0030in. thick and takes a poor quality blurred impression. Paper 6, is the Bothwell watermarked paper, with a visibly strong, coarse vertical mesh, sometimes thicker than .0030in. thick, which takes a good but not crisp impression. The design bleeds through both these papers. Neither of these papers would be considered useful for producing a fake laid paper copy.

Paper 7 is not common. It is a coarse paper, about .0030in thick, with an ivory tone. It has a visible vertical mesh that is not as strong as Paper 6. Very little design bleeds through. The design impression is not as sharp as the submitted stamp. The perforations do not separate cleanly. Once again these characteristics were not consistent with a laid paper copy that was .0036in thick with no evidence of design bleeding through.

At this point there was not a Two Cent Large Queen paper known to the Committee that could produce a credible fake of the laid paper copies.

Finally, the Committee did not believe there was a One Cent Large Queen on thick soft paper, over .0033in thick, on vertically meshed paper that could be used to make a credible fake of the One Cent on laid paper.

The above images of the reference copy One Cent laid paper copy were made beside each of a Duckworth Paper 1 (Figure 6), Paper 6 (Figure 7), and Paper 7 (Figure 8) copy on the VSC6000 using spot fluorescent lighting. They confirm that none of these three vertically meshed papers could produce a credible fake of a laid paper copy. The images of the One Cent laid paper and submitted Two Cent in Figure 3 compare well.

### ANALYSIS OF A FAKED ONE CENT LAID PAPER COPY

The Committee reviewed a contentious One Cent copy (Greene Foundation certificate #F5250) showing laid lines on front and back, measuring about .0030-.0032in thick, with paper that was not particularly fibrous. On close examination the height and width did not measure like a vertically meshed stamp - it was closer to a horizontally meshed copy. The stamp had a Stolow backstamp which often adds suspicion about the genuineness.

The stamp was placed in water beside a genuine One Cent laid and the submitted Two Cent copy. Both of these curled from the sides then flattened out similarly. However, the One Cent #F5250 first displayed a dark shadow along all four sides, then it curled top and bottom, then the sides curled up - clearly it did not behave in a normal fashion. The paper had a slight greyish tone overall in comparison to the creamy white colour of the genuine One Cent and submitted Two Cent stamps. The contentious stamp did not fall apart. Thus if it was rebacked the glue was not water soluble.

As it dried it did not easily go back to a flat stamp - it remained very slightly curled from the sides. Under the VSC 6000 a faintly orange irregular area in the middle of the stamp could be seen on the backside. The Committee believed this stamp had been rebacked using a very thin horizontally meshed copy on front and a very thin laid paper with horizontal lines attached to the back. It was understood that the laid





FIGURE 7. Laid Paper vs. Duckworth Paper 6.

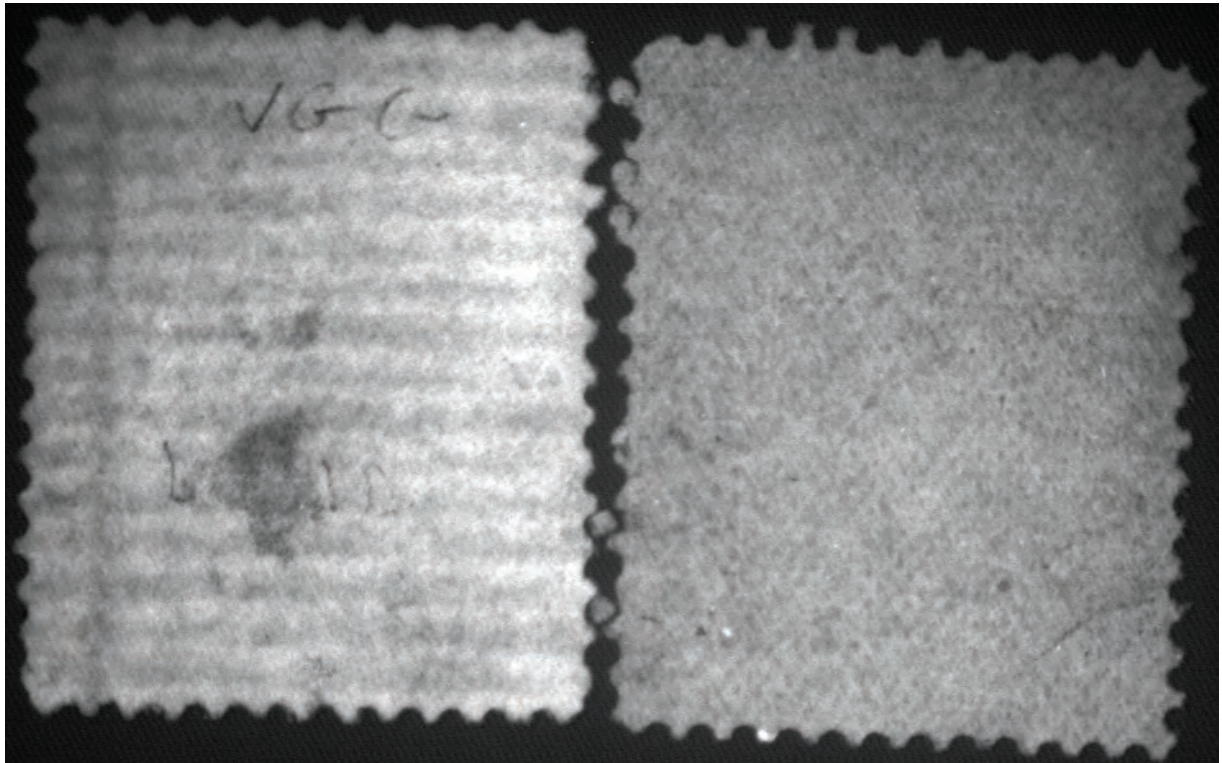

FIGURE 8. Laid Paper vs. Duckworth Paper 7.

paper piece would be vertically meshed. In fact, breathing on the front of this stamp caused it to curl from top and bottom—breathing on the back caused it to curl from the sides.

There were a number of lessons learned from analysis of this very clever fake.

### ANALYSIS OF A FAKED THREE CENT LAID PAPER COPY

The Foundation reference copy of an unused faked Three Cent laid paper copy measures as a horizontally meshed copy with gum added. It was put in water and the gum quickly disappeared. There was no dark shadow around the four sides when submersed. It curled quickly top and bottom, thus indicating it was horizontally meshed. It did not curl from the sides. It did not come apart in the water. It flattened out nicely upon drying and remained flat.

By contrast to the One Cent rebacked fake this Three Cent is not rebacked. But with horizontal laid lines it should have curled from the sides like a vertically meshed stamp—it did not. Rather, since it curled from top and bottom the Committee concluded the laid lines had been faked by impressing or carving them in the paper after printing. The lesson learned was to distinguish whether the fake involves rebacking or impressing lines in a stamp. It was interesting that in each fake the creator did not think to use a vertically meshed stamp.

### THE TWO EXISTING LAID PAPER COPIES

Photos of the two known existing laid paper copies were available (Figure 5). Each was certified as genuine by the Royal Philatelic Society London in 1935.

The first is certificate # 18655 and has the Hamilton “5” two ring cancel. It is centred strongly to the lower right. The

second is certificate #18955 and has the blue “REGISTERED” cancel. It is centred to the top, and just slightly to the right side. Each is said to be on thicker soft paper by two Canadian dealers, Rick Sheryer and John Jamieson who have handled the stamps. The RPSL certificates make no comment about paper thickness, texture or colour.

The submitted Two Cent stamp with the Hamilton date stamp had the same centring and margins as the second existing copy. An enlarged colour photo of the second copy was compared to the submitted copy. Each image appeared to have the same intensity and clarity of impression. The perforations on the 2 ring “5” first copy appear ragged. The perforations on the second copy and the submitted Two Cent are better cut but still reasonably fibrous.

Most important, the submitted Two Cent appeared to be the link between the first two copies as noted above.

### COMPARISON WITH THE TWO EXISTING COPIES

From the outset it was considered helpful if the Committee could get to see one or both of the existing copies. It was recognized that this would never be an easy task to accomplish without conditions being attached to such a review.

However, as the analysis of the submitted Two Cent stamp progressed through a thorough analysis of all Large Queen papers, printing characteristics, features of laid paper and a forensic type of analysis which sought to eliminate what the submitted copy could otherwise have been, it was apparent that an examination of one or both of the existing Two Cent laid paper copies was not critical.

Comparison to the known existing copies undoubtedly carries the potential for an examination that seeks to denigrate the submitted copy in order to protect the first two. The com-

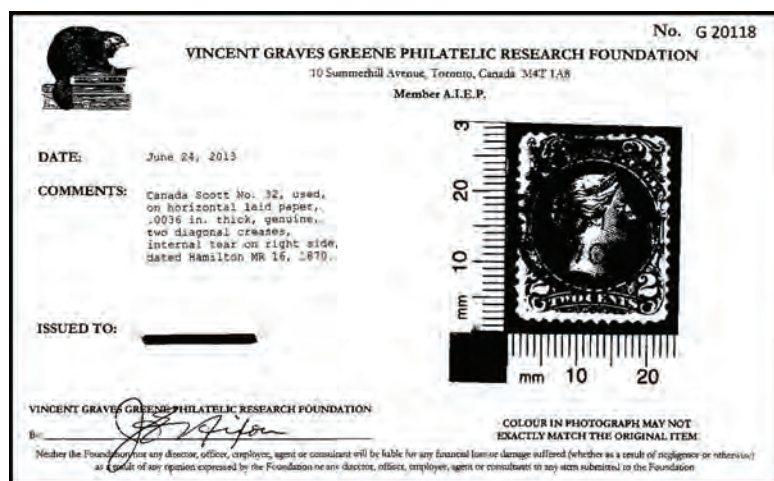

FIGURE 9. Vincent Graves Greene Philatelic Research Foundation Certificate.

parison could focus on the minutiae such as number of fibres in the perforation holes or the intensity of the impression being slightly different. Since the first two were certified 75 years ago the inclination would be to say they are the standard in all respects and a third copy is inferior to the extent its minute characteristics were not identical to the first two. Finally using the comparison as required criteria for issuing a certificate on the submitted Two Cent copy essentially would hold the submitter and the Greene Foundation hostage.

### OPINION OF THE EXPERT COMMITTEE

The purpose of the expertization of the submitted copy was to determine if it was genuinely printed on laid paper. This was successfully accomplished in the opinion of the Committee.

The submitted Two Cent Large Queen stamp with the Hamilton, March 16, 1870 date stamp was genuinely printed on horizontal laid paper which is about .0036 in thick. It has two diagonal creases and has an internal tear on the right side. Certificate G20118 was issued, dated June 24, 2013 (Figure 9).

### CONCLUSION

The lessons and information learned by the Expert Committee in following the rigorous analytical process in this project were very important and have significant application in helping to solve expertization questions on other items. Finally, some of the very simple tests to determine laid paper copies can be done by all collectors.

### REFERENCES

1. *The Large Queen Stamps of Canada & Their Use 1868-72*, by H.E. & H.W. Duckworth, published by the Greene Foundation.
2. Les different papiers utilises pour la production de la serie des Grandes Reines Victoria de 1868-76, by Richard Gratton, *Canadian Philatelist*, July/Aug 2012, Vol 63 #4.
3. Papermaking & its Processing as Related to Large & Small Queens, by Alex Hutton Jr., *BNA Topics*, 2000, Vol 57, Number 1.





# A General Characterization of the Purpose, Role and Responsibilities of Experts and Expertizing Groups When Addressing “Damaged Material”

*Jonas Hällström*

---

**ABSTRACT.** Through the medium of education, philatelic experts help protect philatelists from buying fakes and forgeries that would result in no small amount of grief or expense. Having worked with experts for many years, the following questions have often arisen!

- On what/whose authority are experts confirmed or certified?
- What qualifications should an expert demonstrate prior to his or her certification?
- How can the average collector confirm someone’s representation as being an expert?

This paper will focus on the two paradigms: “purpose” and “responsibility,” addressing the very particular problem of “damaged materials.”

## **IS “DAMAGED MATERIALS” A PROBLEM?**

A couple of years ago, the American Association of Philatelic Exhibitors (AAPE)<sup>1</sup> published in four parts in *The Philatelic Exhibitor*,<sup>2</sup> a very interesting article by Robert M. Bell and Reuben A. Ramkissoon entitled “What is damaged philatelic material?”<sup>3</sup> Bell and Ramkissoon were prompted by the overall question of how judges deal with the condition of philatelic material in the frames. Bell and Ramkissoon saw little had been written about how to clarify the issue of condition and quality, and made a first attempt to fill that need.

When I saw the Bell and Ramkissoon article, the content and their statements interested me particularly as a philatelic judge – how to handle “damaged philatelic material” in competitive exhibits?

As a competitive philatelic exhibitor, one needs to constantly improve the exhibit, developing the story and adding philatelic material to illustrate the story. Adding material usually means buying, and buying means competition for the same pieces among collectors. The “condition” of the particular item very often drives the price.

A philatelic judge has to deal with the “condition” and “quality” when judging. Philatelic items are expected to be the highest available in both. The international world philatelic organization, Fédération Internationale de Philatélie, F.I.P.,<sup>4</sup> defines these circumstances in the GREV (the “General Regulations for the Evaluation of Competitive Exhibits at FIP Exhibitions”).

*Article 3.4. The material displayed should be fully consistent with the subject chosen. The selection should show the appreciation of the exhibitor as to what is available in the context of his chosen subject. It should also include the fullest range of relevant philatelic material of the highest available quality.*

*Article 4.8. The criteria of “Condition and Rarity” require an evaluation of the quality of the displayed material considering the standard of the material that exists for the chosen subject, the rarity and the relative difficulty of acquisition of the selected material.*<sup>5</sup>

**WHAT IS THE “PROBLEM,”  
IF THERE IS ONE?**

One of my philatelic thematic exhibits is “*The History of the Square-Rigged Sailing Vessels.*” Improving the philatelic importance in the exhibit means to look for the best philatelic pieces with sailing vessels.

The first stamp design in 1863 from the Republic of Costa Rica, printed by the “American Bank Note Company” (ABNC), comprises a design using the 1848 national Coat-of-Arms. The design depicts stars, volcanoes and a ship outside the coastal line and port of Puntarenas. In this context, I have been able to follow condition changes on some of the very best postal usages from the first issue of Costa Rica.<sup>6</sup>

These three examples address what I regard as a “problem” for our hobby: - Is it validated and/or permissible to repair and restore philatelic and postal material? If yes, to what extent is it okay? And for what reasons?

I address the fact that money, no doubt, is one of the driving forces. In addition, philately is competitive and exhibitors aim to score as high as possible. The selection of the philatelic material is the founding platform in all exhibits. What differs between two exhibits is always the philatelic material, and the condition of that material always matters.



It is not fair, in my opinion, that one collector pays the highest price for the material, implying condition is excellent or even the best available. While on the other hand, another collector pays less because an item is in poorer condition, then later has it restored, repaired, and cleaned so it appears to be the “best available.” I believe dealers and auction houses are the main customers of the experts and need to address this, show integrity and be open on what has been done to items, if anything.

As the editor of the *Fakes, Forgeries & Experts Journal*,<sup>8</sup> I invited Daisy Todd<sup>9</sup> a paper conservator specializing in philately, to write about the confusion she perceives about the use of the terms ‘conservation’ and ‘restoration.’

She stated “conservation covers all actions to increase the longevity of an item for the benefit of future generations. While restoration refers to the treatment procedures intended to return objects to a known or assumed state and may be more drastic than those carried out by conservators.”

She also stated “It is imperative philatelists realize that they are only temporary possessors of valuable cultural material, and need to begin to re-evaluate and embrace the conservation and preservation techniques that will ensure the longevity of their collections. It is about time the separate professions

**THE FIRST ISSUES OF COSTA RICA**

The 'Cuatro Reales'

1877 (16 November) registered cover (restored at top and bottom edges) from Puntarenas with single 'cuatro reales' and five 'medio real' second plate, one folded over onto the reverse side, (total 75c) with fancy boxed PUN/TA/REN/AS cancels. Endorsed 'No.1914 Certifdo. por acompanante un paquete dinero con peso bulto de 1 lb. 5 1/2 oz'. Dated '16/11/77' and signed by the postal administrator (O. Quesade)

**One of just seven recorded internal registered covers**

Ex Saenz

*This registered letter accompanied a package containing an unspecified amount of money. The basic registration fee was 4 reales or 50c which leaves a balance of 25c which may have paid a higher registration fee, basic postage costs or a combination of both*

FIGURES 1a & 1b (left to right). 1877 registered letter mail from Puntarenas to Liberia with mixed franking, including a single curato reales denomination of which only 12 exist on covers. The entire cover has been cleaned, repaired, and restored to give a much nicer appearance. The cover is presently in the possession of Dr. Arthur Woo in his exhibit *The First Issues of Costa Rica*, in which he states, “The cover has been restored at the top and bottom edges.”<sup>7</sup> The apparent fading of the covers on the right (1b, 2b, and 3b) is not a direct result of cleaning and repairs, but an artefact of the covers being scanned by two different scanners.



of philatelic dealers and conservators began working with one another professionally in the interest of both public and private philatelic collections.”

Another expert scholar, John Hotchner,<sup>10</sup> writes regular columns published in *Linn's Stamp News* published weekly. John discusses expert matters and is not afraid of giving statements about the qualifications of experts: What qualifies someone to become a stamp expertizer? Who appoints experts? What makes “self-appointed” experts so bold in their assertions to be experts? What do you actually get from an expert? In what situation should a stamp or cover be expertized?<sup>11</sup>

In Bell and Ramkissoon’s article, they demand agreements and definitions on these matters. They stated with a hobby that places such importance on the condition of its objects, there should be agreement as to what is damaged or was damaged then repaired. They also proposed definitions to help clarify the relationship between damaged material suitable for exhibiting without penalty, and damaged material that should be penalized.

Hotchner, Bell and Ramkissoon address the fact that philately, in its competitive context, must be clear and fair. Precise definitions on what is acceptable as damaged material, and to what extent damaged material may be restored and repaired to be, or not be, accepted.

John Hotchner gives excellent guidance in *Linn's*.<sup>12</sup>

1. It is now standard practice to accurately describe all condition problems on the certificate.
2. A collector who is considering buying a stamp with a certificate should carefully compare the stamp with both the photograph and the word description on the certificate.
3. Common terminology should be used among all experts in the descriptions.
4. What you get from an expert is only an opinion. It might be and can be questioned by other experts.



5. Certificates from earlier days are sometimes reversed in the current era. Anything with a pre-1990 certificate is recommended to be re-evaluated in most cases.

Having read many of the currently active philatelic experts, I have myself drawn attention to the following findings:

- A. It is expected an expert give his opinion concerning the quality of the item as well as its “genuineness in all regards.”
- B. Difficult-to-acquire covers that have been damaged or consist of poor quality paper, are often restored by a professional for both preservation and appearance for exhibition purpose.
- C. Guidance is needed for exhibitors on when to repair or not to repair, and whether repairing enhances, diminishes, or has no effect on the medal level. Such items should be noted in the exhibit write-up as “restored.” Does repairing an item benefit or detract from the exhibit as a whole? Is it acceptable to restore covers for preservation reasons? But not to alter, enhance or add markings? Is it possible that a damaged cover may be acceptable in one situation but not in another?

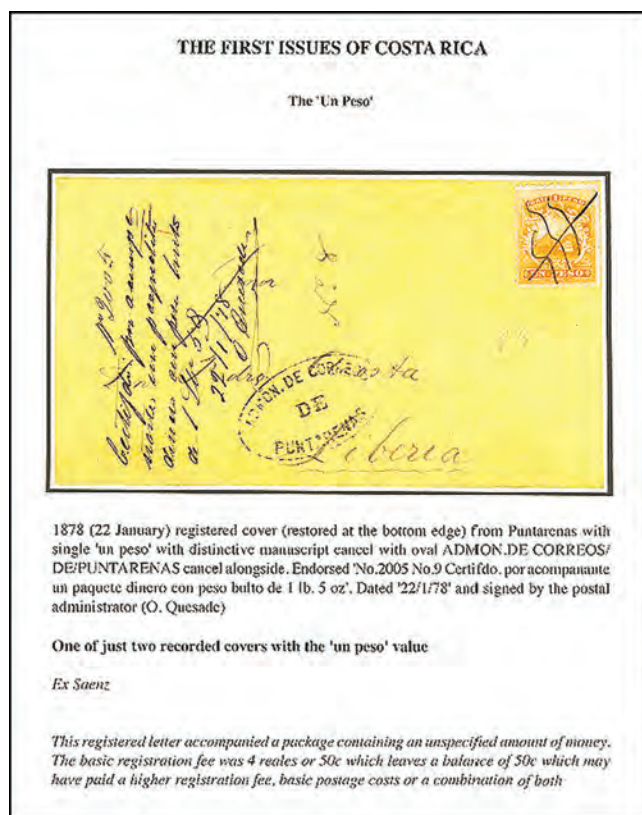

FIGURES 2a & 2b (left to right). 1878 registered letter mail from Puntarenas to Liberia with one of only two recorded single usages of the Un Peso denomination. The entire cover has been cleaned, repaired and restored to give a much nicer appearance. The cover is presently in the possession of Dr. Arthur Woo in his exhibit *The First Issues of Costa Rica*, in which he states, “The cover has been restored at the bottom edge.”

Jay Smith<sup>13</sup> is very clear on his mindset for working as an expert and mixing that with also being a philatelic businessman:<sup>14</sup>

1. In contrast to today's attitude that "everybody can be an instant expert about everything," it took me about 25 years to feel that I was reaching the point where the knowledge I had accumulated could be useful to others. Seeing a philatelic item once or a few times does not qualify one as knowing very much about it. As a dealer, I have a responsibility to my clients to make sure that the descriptions of the stamps I offer for sale are correct and complete, and that they tell the full story of the item, not just the good parts. In fact, my invoices state, "Our exclusive money-back lifetime guarantee assures, to the purchaser, that every item is genuine and as described." The lifetime being referred to is mine.

2. I do make mistakes. Any dealer who says he does not is delusional. But I want to be sure to correct my mistakes whenever possible. The expertizer is often playing an essential role in a financial transaction between two other parties. The expertizer's opinion can mean that one party or the other will make or lose a lot of money.

3. The eventual buyer of a stamp relies on the expert's opinion, sometimes meaning that the buyer makes a decision to spend thousands of dollars on a stamp because he trusts the expert's opinion. It is often said that an expert's opinion is just that, an opinion. Never forget that. It is an opinion, not a fact. It is the expert's best judgement based on experience. The opinion can be wrong, and sometimes it takes decades for the error to come to light. When I started formally doing expertizing work, I thought it was going to be enjoyable. I quickly came to realize that I was wrong — very wrong. I discovered that the process was, for me, uncomfortable. But that is as it should be.

*This responsibility, and the potential consequences, keeps me focused on taking the time to come to the correct opinion, and reminds me to respect the limits of my philatelic knowledge.*

What makes Jay's views interesting and important are that they are so open, transparent and honest.

## CONCLUSION

In the beginning of this paper I promised to focus on experts' "purpose" and "responsibility," addressing the very particular problem of "damaged material." The reasons for that focus have herewith been two driving forces:

A. The market of philatelic material involves money, and the dollar value, most times, is increased by the condition, and the quality of the material. The better the condition, the higher the price. It's a growing issue: one can buy low, invest money in repairs and restoration, then sell very high

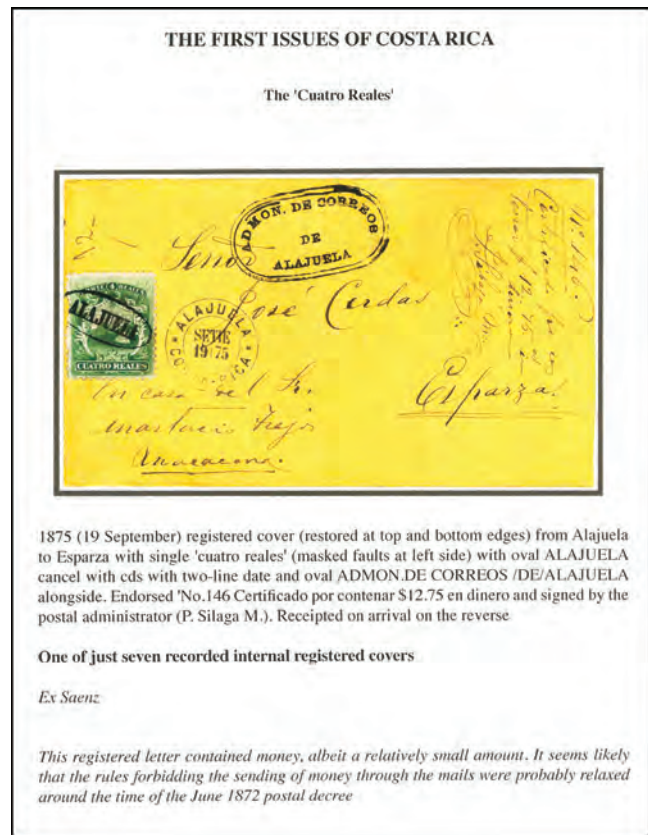

FIGURES 3a & 3b (left to right). 1875 registered letter mail from Alajuela to Esparza with cuarto reales stamp. The cuarto reales denomination is known to exist on 12 items of mail. The above cover is presently in the possession of Dr. Arthur Woo in his exhibit *The First Issues of Costa Rica*. The damaged corner of the stamp has been repaired, and the cover is shown after it was cleaned, repaired, and restored. Dr. Arthur Woo states in his exhibit, "cover restored on top and bottom edges and the stamp has masked faults at left side."

1875 (19 September) registered cover (restored at top and bottom edges) from Alajuela to Esparza with single 'cuatro reales' (masked faults at left side) with oval ALAJUELA cancel with cds with two-line date and oval ADMON. DE CORREOS /DE/ALAJUELA alongside. Endorsed 'No.146 Certificado por contener \$12.75 en dinero and signed by the postal administrator (P. Silaga M.). Received on arrival on the reverse

One of just seven recorded internal registered covers

Ex Saenz

This registered letter contained money, albeit a relatively small amount. It seems likely that the rules forbidding the sending of money through the mails were probably relaxed around the time of the June 1872 postal decree

because the material appears in the best available condition, as long as the dealer, auction house and expertizers notify potential buyers the item was repaired and restored.

B. Philately is, for many of us, a competition. When in competition, one needs clear definitions on what is accepted or not, and what is fair. Is it fair if some collectors search for material over a long time and pay large sums to get it, while others buy low, repair and win Grand Awards with restored material? I will leave you to make this decision.

## NOTES

1. Founded in 1986, the *American Association of Philatelic Exhibitors* is a worldwide organization of stamp collectors who exhibit their collections competitively and work together for the betterment of philatelic exhibiting and judging standards and practices. AAPE membership is open to all philatelists who love and participate in stamp shows.

2. *The Philatelic Exhibitor (TPE)* is the official, award winning, 44-page journal of AAPE, published quarterly, Randy Neil, editor.

3. *The Philatelic Exhibitor (TPE) issues #101-104 published in 2012.*

4. Since 1926, The “Fédération Internationale de Philatélie” (F.I.P.) has looked after stamp collectors and philatelists growing from a society of a handful of European Philatelic Federations to a worldwide Federation with 91 Regular Members (National Philatelic Federations), three Associated Members (Continental Federations), Promotional Members (a new type of Membership for Postal Administrations). The aims of F.I.P. are to promote stamp collecting and philately; to maintain friendly relations and friendship among all; to establish and maintain close relations with the philatelic trade and postal administrations; and to promote philatelic exhibitions by granting Patronage and Auspices.

5. [www.f-i-p.ch](http://www.f-i-p.ch), accessed November 26, 2015.

6. Hector R. Mena, an expert of Costa Rican classic phi-

lately, published “The Ethics of Philatelic Restoration,” in *The Oxcart* (Volume 50, 2011, no. 203), the philatelic journal for the Society for Costa Rica Collectors.

7. The images 1b, 2b, and 3b are used with permission from Dr. Arthur Woo.

8. From the very start, *Fakes, Forgeries & Experts Journal (FFE)* address questions of philatelists, advanced collectors, exhibitors, experts, dealers, auction houses and philatelic organizations. The “simple” purpose of the *FFE* is to explain to collectors how philatelic experts work in their countries, and also to inform and protect collectors from fakes and forgeries items.

9. Daisy Todd (MA) is paper conservator and has undertaken vocational training in libraries, art galleries and museums in the UK, Australia, France, Greece and the USA, and has worked as a paper conservator at The Smithsonian National Postal Museum. See: Daisy Todd *Stop Associating ‘Conservation’ with ‘Restoration’*, in *Fakes, Forgeries & Experts Journal #18* (2015).

10. John Hotchner is a specialist in and exhibitor of U.S. Postal Counterfeits. John is APS expertizer of WW EFOs and 20th century US. He is *Linn’s “U.S. Notes”* columnist for 27 years, Co-founder of *American Association of Philatelic Exhibitors* and editor of *The Philatelic Exhibitor* for 24 years. Past president and 16 year board member of the APS. Member, Council of Philatelists at the Smithsonian National Postal Museum. Member of U.S. Postmaster General’s Citizens Stamp Advisory Committee (1998- 2010). John is national exhibitor with two exhibits in “Champion of Champions.”

11. John M Hotchner in *Linn’s “U.S. Notes”* columns published in several issues in 2014. *Linn’s Stamp News* published weekly by Amos Media Company.

12. Hotchner, *Linn’s “U.S. Notes”* columns, 2014.

13. Jay Smith owns and operates “Jay Smith & Associates” along with his partner and wife Bonnie, and three other staff members. Since 1970, he has been a dealer and has specialized in Scandinavian philately since 1973. The firm also stocks U.S. and worldwide stamps.

14. Jay Smith “The process of expertizing should be uncomfortable” published on *Linns.com* accessed on 4/17/2014.





# Analysis of Pigment Composition of the U.S. 5c 1847 Issue

*Gordon Eubanks and Harry Brittain Ph.D.*

Non-destructive techniques of X-ray diffraction (XRD) and infrared absorption spectroscopy with attenuated total reflectance sampling (IR-ATR) determined the ink compounds used to print the first United States 1847 5¢ stamps. XRD identified lead sulfide and lead tetroxide, while IR-ATR demonstrated the presence of white calcium carbonate.

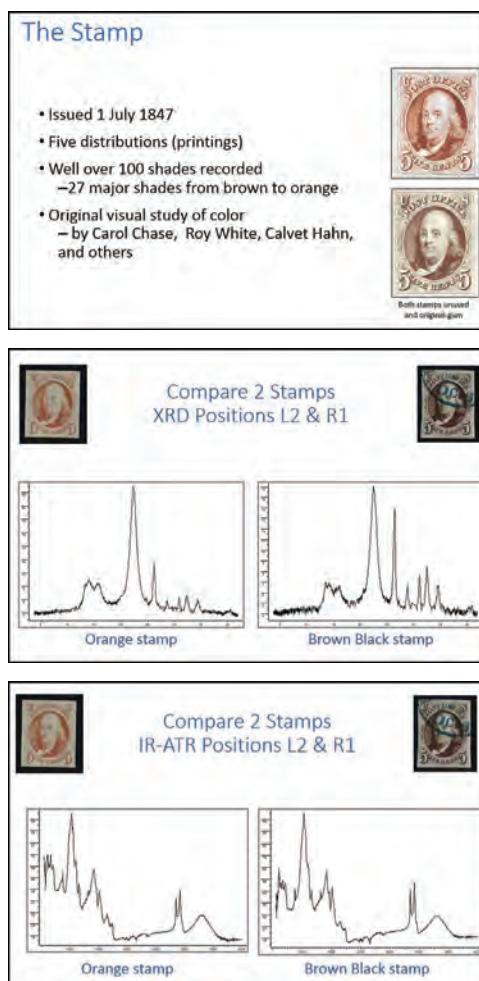





# The Use of X-ray Fluorescence in Detecting Philatelic Forgeries

*Thomas Lera*

This study demonstrated conclusively that XRF spectrometry can be used as a suitable method for analyzing different ink types used by the well-known forgers Francois Fournier and Jean De Sperati.

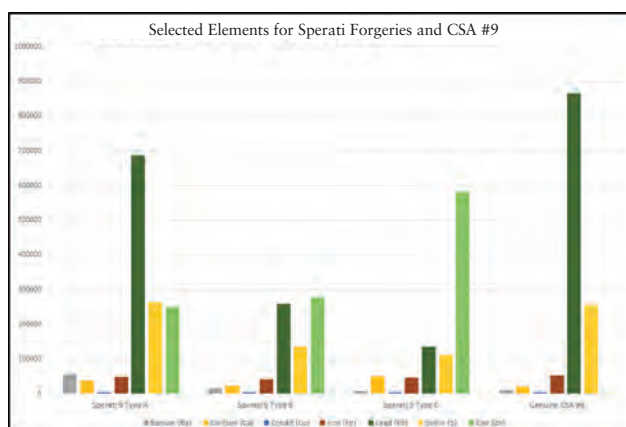
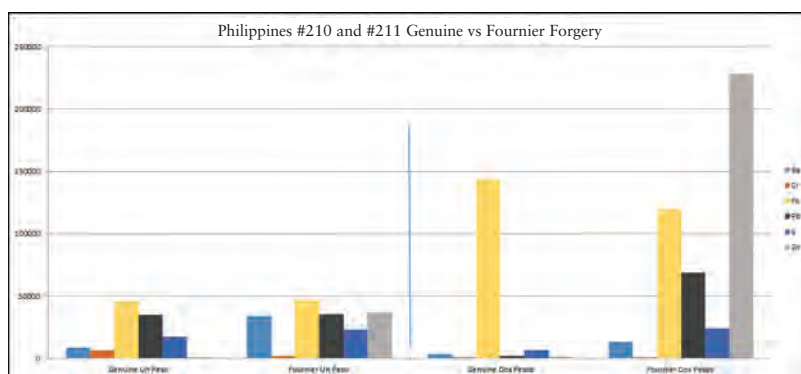

Fournier (grey) and Sperati (light green) both have more zinc than was used in the genuine stamps. This could have been zinc soaps which are formed really easily and fast when any zinc oxide is mixed with linseed oil. It is believed these forgers probably had access to crude ink recipes. James Allen suspects “If they made them themselves, the grinding and mixing of the oil with the zinc colorants would be all it would take to make the soap.”

I would like to thank both Steven Roth for allowing me to analyze his CSA and Sperati stamps and Don Pederson for his Philippines and Fournier stamps. Scott Numbers are from: *2015 Standard Postage Stamp Catalogue*, Scott Publishing Co. Sidney, Ohio.



# A New Technique for Analyzing the Optical Spectra of Stamp Inks: U.S. 1861 Stamps<sup>1</sup>

*Edward (Ted) Liston Ph.D., FRPSL*

The apparent difference between stamps is often the color of the inks used to print them. While the eye can distinguish millions of different colors, without good reference stamps one person's "red" could be another person's "red-orange." The appearance of the color also depends on the particular light used to illuminate the stamp. The only reliable way of establishing the true color of ink on a stamp is by measuring the amount of light reflected from the ink, the plot of which is called a "Spectrum." There are now instruments available at several philatelic organizations able to make this measurement.

The problem is, very little information is available from the raw spectrum measured by these instruments. Often, the spectrum is just a line containing broad bumps showing little variation among different copies of the same issue of stamps, or even between totally different colors. A simple computer technique has been developed that exaggerates small differences within each spectrum curve to form a new, much more detailed spectrum for each stamp. This Figure shows a Raw Spectrum produced by the VSC6000 (the blue curve), and the Difference Spectrum calculated using the raw data (the red curve).

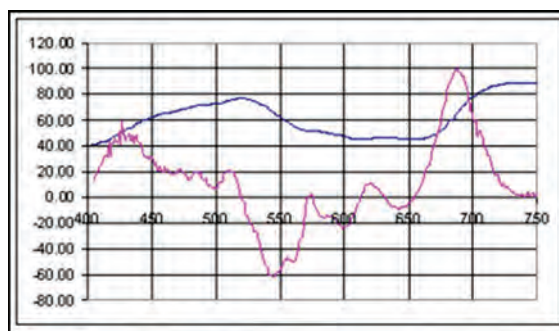

The new Difference Spectrum becomes the source of important spectral information present in an Average Spectrum, but almost invisible in the raw data. The real power of this new technique is in the comparison among Difference Spectra which makes it possible to see differences in the composition of the stamp inks.

This technique was tested on several US 1861–1862 "Pink" and "Rose" stamps (Scott #64 and #65) by looking for differences in the spectra among certified rose, rose pink, pink, and pigeon blood pink stamps. The data showed the plots of Difference Spectra of these stamps had very different shapes and therefore, much more information about the different inks. It may possible to use these spectra to determine which pigments were used by comparing the stamp spectrum with the spectra of different pigments (burnt sienna, ultramarine blue, red lead and rose madder.)

## NOTES

1. Liston, Edward (Ted). 2016. "A New Technique for Analyzing the Optical Spectrum of U.S. Stamp Ink - A U.S. 1861 Case Study." *Collectors Club Philatelist*, July-August 2016, Vol. 95, No.4: 244-250.





# Application of Advanced Tools to Persian Philately

*K. Joe Youssefi*

A variety of analytical tools and methods were evaluated at the National Postal Museum applicable to all areas of philately. Nineteen experiments involving Persian philately were briefly reviewed including the results of two of the evaluations that yielded significant new findings.

**Light Microscope**  
Olympus BX46



- UIS2 optical system
- High color reproductivity LED light source
- Koehler illumination for transmitted light
- Light intensity manager switch
- Fixed reverse coded quintuple nosepiece
- Up to 400X magnification
- 15mm focus stroke
- 1µm fine focusing knob



45X Paper & Ink

Lion Stamp  
1 Kran Red  
Yellow Paper

**Results L6**

L6 - Analysis of 1 Toman Copper Bronze Variety

Is 1 Toman Copper Bronze a color variety, or a manipulated item?

Paper and Ink Variation



Light Microscope Evaluation

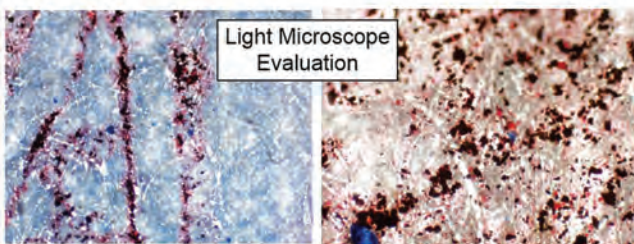







# Support the IAP

---

Institute for Analytical Philately, Inc.  
 PMB 31, 1668 Merriman Road  
 Akron, OH 44313

Level	Annual Amount	My Payment
Patron*	\$100	\$ _____.
Sponsor*	\$100	_____.
Supporting	\$100	_____.
Sustaining	\$50	_____.
Institutional	\$250	_____.
Additional donation		_____.
Total		\$ _____.

You may donate through PayPal (knilsestuen@analyticalphilately.org) or by sending a check payable to the “Institute for Analytical Philately, Inc.” to the address above.

Your donation may be tax deductible since the Institute is a tax-exempt organization under Section 501 (c) (3) of the Internal Revenue Code. We will provide a receipt to you.

Thank you again for your support.

\*Patron and Sponsor levels require \$5,000 and \$2,000 initial pledges and \$100 annual contribution.

Name \_\_\_\_\_

Street \_\_\_\_\_

City, State, Post code, Country \_\_\_\_\_

Email \_\_\_\_\_@\_\_\_\_\_

Phone number \_\_\_\_\_





# Application for an IAP Research Grant

---

The initial application should include information describing yourself and your proposed research effort. This information will be used to evaluate its merits and relationship to the mission of the Institute for Analytical Philately, Inc. (IAP). You will then be contacted by one of the institute's directors to further discuss your proposal. The greatest weight is given to projects that develop new methodologies which promise to be of lasting significance to philately. Good project proposals result from clearly thought-out and organized plans because you are trying to convince a "buyer" you are "selling" a great product. The general proposal sections should include:

## **EXECUTIVE SUMMARY**

In this section, you should describe the project you plan to do, why it is important, and how it will benefit philately. Write this section as if the person reading it has no idea of what the technical details are, so they can immediately grasp the potential and importance of your idea.

## **TECHNICAL APPROACH**

This is the technical meat of your proposal. In this section, describe the tasks you will perform and the manner in which you plan to successfully perform them. Ideally, you should also estimate the scope (for our purpose, in elapsed calendar time) so later you can develop a project schedule.

## **STATEMENT OF WORK**

This is a recap of the tasks defined in your Technical Approach. You can use this as a checklist to determine if your plan is succeeding. It will be incorporated in the Research Grant Agreement you enter into with IAP, should your proposal be selected.

## **COST AND SCHEDULE**

Estimate the amount of funding you will need to perform your effort. Remember, all IAP Grants are firm, fixed-price agreements. Grants typically range from \$2,000 to



\$4,000 and are intended to help fund travel, lodging, and laboratory use. You are agreeing to perform the tasks set forth in the Statement of Work for a set fee. There is no opportunity to receive additional funding on a selected proposal.

### **FINAL REPORT AND PUBLICATION**

In this section, present an outline of how you expect your final report to look, and the technical and philatelic journals to which you will submit your article for publication under IAP auspices.

### **RESUME OF PROPOSER**

Provide a summary of both your professional and philatelic accomplishments. It is neither necessary nor desired for you to provide long lists of technical papers you may have authored during your career. It is sufficient to make statements such as "...resulting in dozens of journal articles." The IAP is more interested in your ideas and philatelic accomplishments. A professional scientific background simply adds additional credence to your proposal, and helps convince the reviewer there is a good probability the project will satisfy its goals.

Additional information and application for each research grant can be found at <http://www.analyticalphilately.org/applyingforagrant.html>.

# 2017 Call for Papers for the Third International Symposium in London

*13-15 October 2017*

*The Royal Philatelic Society London*

---

*Sponsored by*

*The Institute for Analytical Philately, Inc. (IAP)*

*The Royal Philatelic Society London (RPSL)*

*The Smithsonian National Postal Museum (NPM)*

## **CALL FOR PAPERS**

The Symposium's format will allow for twelve technical papers. Each paper must be previously unpublished, and address how forensic analysis was applied to solve a philatelic problem. Technical studies of stamp characteristics (color, ink chemistry, paper, gum, etc.) and postal history items are welcome. Papers addressing methodology are preferred rather than a simple study or expertization that does not advance the state of the art in methods with broad applicability.

Abstracts of 500 words or less must be submitted electronically by 30 November 2016 to [Symposium@AnalyticalPhilately.org](mailto:Symposium@AnalyticalPhilately.org). Proceedings will be published in a bound volume by the Smithsonian Institution Scholarly Press.

## **HIGHLIGHTS OF THE SYMPOSIUM**

The symposium will be chaired by Chris Harman RDP Hon. FRPSL, and will comprise technical presentations and discussions on 14-15 October. A day of viewing of the RPSL Expert Committee's premises, and demonstrations of technical equipment, to be held on 13 October, will be open to symposium delegates and RPSL fellows and members. Exhibited will be a Foster & Freeman VSC 6000, a Bruker Tracer III-SD X-ray Fluorescence spectrometer, and a Bruker FT-IR (Fourier Transform Infrared) spectrometer. On 12 October at 5:00, Thomas Lera will give a presentation open only to RPSL fellows and members.

**Keynote Address:** Chris Harman, RPSL Expert Committee Chairman

## **CALL FOR DELEGATES**

Presentations and discussions on 14-15 October are open only to registered delegates. The venue will support a limited attendance, so advanced registration is imperative to ensure a seat. A registration fee of £100 will cover refreshments and lunches at the venue, and may be paid through the IAP web site:

[www.AnalyticalPhilately.org](http://www.AnalyticalPhilately.org), and selecting the "Symposium" item on the left side of the screen.

# Author Contacts

---

Robert Odenweller	rpodenweller@verizon.net
Thomas Lera	frontier2@erols.com
Archie McKee	archie.mckee@hotmail.com
Richard Judge	ch2se@sbcglobal.net
John Cibulskis	jcibulskis@sbcglobal.net
John Barwis	jbarwis@charter.net
Robert Mustacich	bob@mustacich.com
Tim Lyerla	tlyerla@clarku.edu
Farley Katz	farleypkatz@gmail.com
Diane DeBlois & Robert Harris	agatherin@yahoo.com
Ted Nixon	tednixon2@gmail.com
Jonas Hallstrom	j.hallstrom@telia.com
Ted Liston	tedliston@comcast.net
Joe Youseffi	joejcy@cox.net
Gordon Eubanks	gordoneubanks@gmail.com